



HR EXCELLENCE IN RESEARCH

## TABLE OF CONTENTS

1. PRESENTATION OF INSTITUTE .....	1
2. SCIENTIFIC COUNCIL OF THE INSTITUTE .....	5
3. RESEARCH UNITS .....	7
4. RESEARCH AND DEVELOPMENT	
4.1. DEPARTMENT OF BIOSYSTEMS AND SOFT MATTER .....	8
4.2. DEPARTMENT OF EXPERIMENTAL MECHANICS .....	14
4.3. DEPARTMENT OF INFORMATION AND COMPUTATIONAL SCIENCE .....	21
4.4. DEPARTMENT OF INTELLIGENT TECHNOLOGIES .....	26
4.5. DEPARTMENT OF MECHANICS OF MATERIALS .....	32
4.6. DEPARTMENT OF THEORY OF CONTINUOUS MEDIA AND NANOSTRUCTURES .....	39
4.7. DEPARTMENT OF ULTRASOUND .....	45
4.8. LABORATORY OF POLYMERS AND BIOMATERIALS .....	50
4.9. JOINT LABORATORY OF MULTIFUNCTIONAL MATERIALS .....	54
5. CENTRES .....	56
6. NATIONAL CONTACT POINT FOR RESEARCH PROGRAMMES OF THE EU .....	60
7. 2016-2017 PUBLICATIONS .....	64
8. TOWARDS INNOVATION AND IMPLEMENTATION .....	65
9. 2016-2017 PROJECTS .....	70
10. INTERNATIONAL SCIENTIFIC CO-OPERATION .....	80
11. CONFERENCES ORGANISED AND CO-ORGANISED BY IPPT PAN .....	91
12. PROMOTIONS AND IMPROVEMENT OF SCIENTIFIC QUALIFICATIONS .....	97
13. THE DOCTORAL STUDY .....	106
14. CONSORTIUMS .....	109
15. PRESTIGIOUS AWARDS IN 2016-2017 .....	112
16. JUBILEE CELEBRATION ON THE 70TH BIRTHDAY OF PROF. MICHAŁ KLEIBER .....	114
17. THE WITOLD NOWACKI LIBRARY .....	116
18. PUBLISHING OFFICE .....	118
19. POPULARIZATION OF SCIENCE .....	122
20. ADMINISTRATION UNITS .....	123
21. STAFF AT THE INSTITUTE .....	142



## DIRECTOR'S NOTE

We present a synthetic Report on scientific activities of the Institute of Fundamental Technological Research of the Polish Academy of Sciences, for the years 2016 – 2017.

The Report contains substantive description of research studies conducted at the Institute's scientific units, the research projects, most important events and the list of works published in that period.

The Institute was erected by the Scientific Secretary of the Polish Academy of Sciences on 2 December 1952 and formally brought into existence by the Polish Government on 20 October 1953. Therefore, it has now been 65 years since the Institute was founded.

At present, the Institute of Fundamental Technological Research is the largest institute of the Polish Academy of Sciences in the field of engineering sciences, researching in such scientific disciplines as mechanics, materials engineering, electronics, information and computational sciences. It has maintained the highest scientific category A+ assigned during the previous

period of the scientific evaluation performed by the Ministry of Science and Higher Education.

Theodore von Karman, a very well-known scientist, once said: "Scientists discover the world that exists, engineers create the world that never was". Following his thought, the Institute's mission is to concentrate on the second part of research activities and to conduct scientific studies at the highest scientific level but our studies extend beyond the scope of engineering sciences, including research in biology and medicine.

This biennial also presents activities of the Institute on the 3rd university education level in the form of the Doctoral Study at above-mentioned scientific disciplines. The Doctoral Study at the Institute was established in 1968 and it is one of the first among the scientific institutes of the Polish Academy of Sciences.

Since 1998, the Institute in Poland has played the role of the National Contact Point for Research Programmes of the EU and since 2014, it has concentrated on supporting Polish scientists in applying to Horizon 2020 funds. A synthetic summary of those activities can be found in the Report.

In December 2016, the Institute was awarded the HR Excellence in Research logo by the European Commission (EC). EC thus acknowledged the Institute and its activities, achievements and plans aiming at ensuring favourable conditions for the HR development, in particular the development of researchers.

The Institute is also a member of the Biocentrum Ochota scientific consortium and, together with other institutes of the consortium, forms the largest and strongest group of scientific experts of the Polish Academy of Sciences, bringing together highly valued specialists from Poland and abroad.

We wish you a pleasant and interesting read.

**Tadeusz Burczyński**  
Director of IPPT PAN

## BOARD OF DIRECTORS



**Director:**  
**Prof. Tadeusz Burczyński**  
Corresponding Member of PAN

Secretary: Magdalena Palińska  
phone: +48 22 826 89 11 / +48 22 826 12 81 ext. 112



**Deputy Director for Research:**  
**Prof. Janusz Szczepański**

Secretary: Aneta Ciesielska  
phone: +48 22 828 53 73 / +48 22 826 12 81 ext. 114



**Deputy Director for Planning and Administration:**  
**Assoc. Prof. Piotr Kowalczyk**

Secretary: Magdalena Palińska  
phone: +48 22 826 89 11 / +48 22 826 12 81 ext. 112



**Deputy Director for Investments:**  
**Andrzej Krawczyk, M.Sc.**

phone: +48 22 826 65 08 / +48 22 826 12 81 ext. 295



**Chief Accountant:**  
**Anna Leśnicka, M.Sc.**

phone: +48 22 826 98 13 / +48 22 826 12 81 ext. 118



**Director of National Contact Point  
for Research Programmes of the EU:**  
**Zygmunt Krasieński, Ph.D.**

phone: +48 22 828 74 83

## 1. PRESENTATION OF THE INSTITUTE

The aim of the Institute of Fundamental Technological Research of the Polish Academy of Sciences is to carry out high-quality and versatile research in various areas of science and technology, especially those drawing most attention of the scientific world.

Over 65 years of its existence has given the Institute a unique foundation for fostering the development of science, worthy of modern times. Currently, the Institute employs 90 researchers, including 21 professors. The Institute's employees occupy many prestigious international and national positions, are appointed members of international organisations, significant conference committees, members of council boards of leading scientific journals and are invited to plenary and conference lectures around the world.

Extensive experience of the scientific staff linked with the commitment and pro-active attitude of junior staff members gives solid grounds for undertaking

broader and more ambitious aims and carrying out world-scale quality of research and development.

The number of fellows and junior researchers at the Institute is constantly rising, as they seek unique experience and fully professional support in the development of their scientific careers, knowing that the Institute fosters its progressive image by maintaining contact with leading regional, national, and international partners in science and industry and successfully applies for both national and foreign research grants, leading numerous multi-discipline projects.

Simultaneously, the Institute is fully dedicated to the development of its infrastructure. All Institute laboratories are equipped with state-of-the-art, often unique, scientific apparatus, which promotes the IPPT PAN to the position among the best research centres of its kind in Poland and provides excellent opportunities for further development.

The Institute is always open to newcomers, offering them the opportunity to learn about its current scientific activity, staff and all laboratory facilities.



Fig. 1.1. The façade of the Institute's headquarters

## MISSION

- ✓ To be the reference centre for scientific and technological excellence, radical innovation, and implementation of technology achievements in the Polish scientific and industrial environment;
- ✓ To start up and participate in activities related to multifunctional materials, polymers, smart materials and technologies, biomedical applications of ultrasound and microfluidic technologies, applied information science, and innovation technologies;
- ✓ To provide first-rate Ph.D. education in contemporary technology, mechanics, acoustics, computing, and their advances related to biomedical applications, enhanced by internationalisation, links with industry, and the encouragement of the spirit of discovery. The Institute has been very active in operating its own postgraduate school (established in 1968);
- ✓ To promote, support, drive and implement research and technology transfer, initiatives and activities, and links with industry and commerce to contribute to the sustainable development of society.



## PRINCIPAL RESEARCH ACTIVITIES

- ✓ Advanced problems in modern mechanics and materials science, multicomponent and multifunctional materials, nano-materials, shape memory alloys, testing techniques for fatigue and creep investigation of materials, design of microstructure and 2D nanostructure, diagnostic methods for advanced materials, laser technology development for super hard materials, ultrasound diagnostics in materials and structures;
- ✓ Information science and computational methods in mechanics and materials science, multiscale modelling and optimization of material systems, computational intelligence, intelligent technologies in engineering – smart materials and structures, dynamics and control of transport systems;
- ✓ Bioengineering, biotechnology directed to medicine and biomaterials, system biology, bioinformatics, cell signaling and immune response, electrospinning fibers designed to tissue restoration and to drug release, microflows and polymer nanofibers for biomedical applications, ultrasonic investigation and imaging of biological tissues and human organs;
- ✓ Environmental engineering and renewable power energy.

Fig. 1.2. Main entrance of the IPPT building

# 2. SCIENTIFIC COUNCIL OF THE INSTITUTE

The Scientific Council is a major organ of the Institute for initiative, opinion, advice and execution with respect to statutory scientific activity and matters related to the staff involved in the research.

The current Institute's Scientific Council was constituted on January 22, 2015. It is comprised of 50 persons, including elected 30 Institute's employees, 17 external representatives, a delegate of Ph.D. students, the Director of the Institute, and the Deputy Director for Science. The Scientific Council's tenure lasts for 4 years.

The Council has the right to confer Ph.D. and habilitation degrees in:  
**Mechanics, Electronics, Informatics, Materials Engineering**

## PRESIDIUM OF THE SCIENTIFIC COUNCIL



Prof.  
**HENRYK PETRYK**  
Chairman



Prof.  
**JANUSZ KACPRZYK**  
Vice-chairman



Prof.  
**TOMASZ A. KOWALEWSKI**  
Vice-chairman



Prof.  
**JERZY ROJEK**  
Vice-chairman



Assoc. Prof.  
**ZBIGNIEW RANACHOWSKI**  
Secretary

**Scientific Council Secretary:** phone: +48 22 826 54 73; 22 826 12 81 ext. 115, e-mail: radanauk@ippt.pan.pl

## THE LIST OF THE COUNCIL'S MEMBERS:

Prof. Czesław Bajer  
 Assoc. Prof. Michał Basista  
 Prof. Romuald Będziński  
 Prof. Tadeusz Burczyński  
 Prof. Paweł Dłużewski  
 Prof. Maria Ekiel-Jeżewska  
 Prof. Ewa Grabska  
 Prof. Witold Gutkowski  
 Prof. Jan Holnicki-Szulc  
 Assoc. Prof. Łukasz Jankowski  
 Prof. Leszek Jarecki  
 Prof. Janusz Kacprzyk  
 Prof. Tomasz Kapitaniak  
 Assoc. Prof. Piotr Kiełczyński  
 Prof. Michał Kleiber  
 Prof. Józef Korbicz  
 Prof. Zbigniew Kotulski  
 Assoc. Prof. Piotr Kowalczyk  
 Assoc. Prof. Katarzyna Kowalczyk-Gajewska  
 Prof. Tomasz A. Kowalewski  
 Prof. Zbigniew L. Kowalewski  
 Prof. Stefan J. Kowalski  
 Assoc. Prof. Stanisław Kucharski  
 Jakub Lengiewicz, Ph. D.  
 Marcin Lewandowski, Ph. D.

Prof. Tomasz Lewiński  
 Prof. Tomasz Lipniacki  
 Prof. Jerzy Litniewski  
 Prof. Bogusław Major  
 Prof. Roman Maniewski  
 Prof. Krzysztof Marasek  
 Assoc. Prof. Mirosław Meissner  
 Prof. Zenon Mróz  
 Prof. Wojciech Nasalski  
 Prof. Andrzej Nowicki  
 Prof. Wiera Oliferuk  
 Prof. Ryszard Pęcherski  
 Prof. Henryk Petryk  
 Assoc. Prof. Elżbieta Pieczyska  
 Assoc. Prof. Katarzyna Pietrzak  
 Assoc. Prof. Zbigniew Ranachowski  
 Prof. Jerzy Rojek  
 Prof. Paweł Sajkiewicz  
 Prof. Stanisław Stupkiewicz  
 Prof. Janusz Szczepański  
 Assoc. Prof. Tomasz Szolc  
 Prof. Zygmunt Szymański  
 Michał Wichrowski, M.Sc.  
 Prof. Krzysztof Wiśniewski  
 Assoc. Prof. Janusz Wójcik



Fig. 2.1. Commemorative photo from the first session of the Scientific Council

## 3. MAIN RESEARCH UNITS

### DEPARTMENT OF BIOSYSTEMS AND SOFT MATTER

**Head: Prof. Tomasz Lipniacki**

**Deputy Head: Prof. Tomasz A. Kowalewski**

Secretary: Agnieszka Ponarska

phone: +48 22 826 98 03; +48 22 826 12 81 ext. 228

e-mail: aponar@ippt.pan.pl

### DEPARTMENT OF INFORMATION AND COMPUTATIONAL SCIENCE

**Head: Assoc. Prof. Piotr Kowalczyk**

Secretary: Zofia Grzechnik

phone: +48 22 826 96 15; +48 22 826 12 81 ext. 164

e-mail: zgrzech@ippt.pan.pl

### DEPARTMENT OF MECHANICS OF MATERIALS

**Head: Prof. Henryk Petryk**

**Corresponding Member of PAN**

Secretary: Agnieszka Sokalska

phone: +48 22 826 98 34; +48 22 826 12 81 ext. 255

e-mail: alyszk@ippt.pan.pl

### DEPARTMENT OF ULTRASOUND

**Head: Prof. Jerzy Litniewski**

Secretary: Monika Węglowska

phone: +48 22 826 98 41; +48 22 826 12 81 ext. 219

e-mail: mweglow@ippt.pan.pl

### JOINT LABORATORY OF MULTIFUNCTIONAL MATERIALS

**Head: Prof. Paweł Sajkiewicz**

Secretary: Aneta Ciesielska

phone: +48 22 828 53 73; +48 22 826 12 81 ext. 114

### CENTRE FOR BIOMEDICAL RESEARCH

**Head: Prof. Tomasz Lipniacki**

phone: + 48 22 826 12 80 ext. 409

### DEPARTMENT OF EXPERIMENTAL MECHANICS

**Head: Prof. Zbigniew L. Kowalewski**

Secretary: Agnieszka Sokalska

phone: +48 22 826 98 34; +48 22 826 12 81 ext. 255

e-mail: alyszk@ippt.pan.pl

### DEPARTMENT OF INTELLIGENT TECHNOLOGIES

**Head: Assoc. Prof. Łukasz Jankowski**

Secretary: Zofia Grzechnik

phone: +48 22 826 96 15; +48 22 826 12 81 ext. 164

e-mail: zgrzech@ippt.pan.pl

### DEPARTMENT OF THEORY OF CONTINUOUS MEDIA AND NANOSTRUCTURES

**Head: Prof. Ryszard Pęcherski**

Secretary: Monika Węglowska

phone: +48 22 826 98 41; +48 22 826 12 81 ext. 219

e-mail: mweglow@ippt.pan.pl

### LABORATORY OF POLYMERS AND BIOMATERIALS

**Head: Prof. Paweł Sajkiewicz**

Secretary: Agnieszka Ponarska

phone: +48 22 826 98 03; +48 22 826 12 81 ext. 228

e-mail: aponar@ippt.pan.pl

### CENTRE OF EXCELLENCE AND INNOVATION FOR COMPOSITE MATERIALS

**Head: Assoc. Prof. Michał Basista**

phone: + 48 22 826 12 81 ext. 212

### CENTRE FOR INTELLIGENT TECHNOLOGIES

**Head: Prof. Jan Holnicki-Szulc**

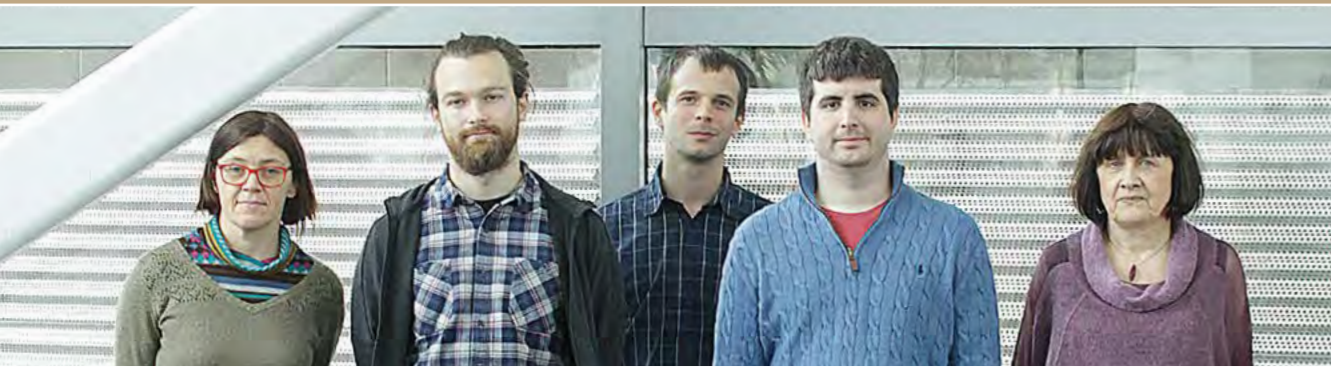
phone: +48 22 826 12 81 ext. 355

# 4.1. DEPARTMENT OF BIOSYSTEMS AND SOFT MATTER



**Head:**  
**Prof. Tomasz Lipniacki**  
**Deputy Head:**  
**Prof. Tomasz A. Kowalewski**

Secretary: Agnieszka Ponarska  
room: 329  
phone: +48 22 826 98 03  
+48 22 826 12 81 ext. 228  
e-mail: aponar@ippt.pan.pl



The department has two divisions:

- Modelling in Biology and Medicine (Prof. Tomasz Lipniacki)
- Complex Fluids (Prof. Maria Ekiel-Jeżewska)

and one laboratory:

- Bio and Micro Fluidics (Sławomir Błoński, Ph.D.)

## STAFF:

### Professors

Prof. Tomasz A. Kowalewski, Ph.D., D.Sc.  
Prof. Tomasz Lipniacki, Ph.D., D.Sc.

### Associate Professors

Prof. Maria Ekiel-Jeżewska, Ph.D., D.Sc.  
Bogdan Kaźmierczak, Ph.D., D.Sc.  
Prof. Janusz Szczepański, Ph.D., D.Sc.

### Technical staff

Sławomir Białecki, M.Sc.  
Sławomir Błoński, Ph.D.  
Marek Bukowicki, M.Sc.  
Magdalena Gruziel, Ph.D.  
Beata Hat-Plewińska, Ph.D.  
Paweł Kocieńewski, M.Sc.  
Sylwia Pawłowska, M.Sc.  
Karolina Zakrzewska, Ph.D.  
Paweł Żuk, Ph.D.

### Senior Researchers

Maciej Czerkies, Ph.D.  
Joanna Jaruszewicz-Błońska, Ph.D.  
Marek Kochańczyk, M.Sc.  
Michał Komorowski, Ph.D.  
Piotr Korczyk, Ph.D., D.Sc.  
Zbigniew Korwek, Ph.D.  
Paweł Nakielski, Ph.D.  
Izabela Piechocka, Ph.D.  
Filippo Pierini, Ph.D.  
Agnieszka Pręgoszka, Ph.D.  
Wiktor Prus, Ph.D.  
Agnieszka Słowicka, Ph.D.  
Krzysztof Zembrzycki, M.Sc.

### Ph.D. Students

Paramita Chatterjee, M.Sc.  
Marcin Jakubiak, M.Sc.  
Karol Nienałtowski, M.Sc.  
Chris Trombley, M.Sc.  
Damian Zaremba, M.Sc.

The department consists of two divisions Modelling in Biology and Medicine (<http://pmbm.ippt.pan.pl>) and Complex Fluids. Our research activities concentrate on the areas of systems and cellular biology, development of biopolymers for medical and technological applications, microfluidics, dynamics of micro- and nano-particles in fluids, physics of suspensions and problems of mathematical physics and biology. These research

activities were supported by nearly 20 national and European grants. As a result a number of publications in high rank journals, including J. Fluid Mechanics, Soft Matter, J. Chem. Phys., Macromolecules, Polymer, PLOS Computational Biology, Science Signalling, Bioinformatics, Journal of Differential Equations, Mathematical Models and Methods in Applied Science appeared. This report highlights our main achievements in 2016-2017.

## ELECTROSPINNING OF CONJUGATED POLYMER NANOFIBERS

Conjugated polymers are a class of organic macromolecules with long  $\pi$ -conjugated polymer chains (i.e. having a backbone chain of alternating double and single-bonds). Their highly electron-delocalised structures generate new fascinating electronic and optical properties. Single-material organic solar cells (SMOCs) are based on polymers with the covalent linking of electron accepting moieties to a hole-transporting conjugated polymer. SMOC efficiency, however, is affected by the charge recombination and randomly-directed transport in their structures composed by randomly oriented polymer chains. This can be solved by electrospinning, the most efficient technique for elongating and aligning polymer chains to form nanofibers with a controllable composition and well-defined structure and properties.

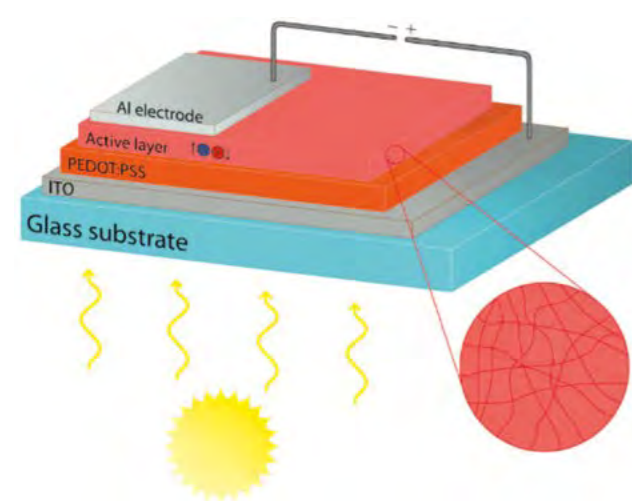


Fig. 4.1.1. Structure and photovoltaic properties of an electrospun nanofiber-based SMOC

In our experimental study, we have developed a nanofiber-based SMOC (Fig. 4.1.1.) with high power conversion efficiency. The synthesis of a new donor-acceptor double-cable conjugated copolymer, used for the fabrication of continuous and uniform electrospun nanofibers integrated into SMOCs led to a great improvement of the photovoltaic cell

performance. We demonstrated that SMOC efficiency can be substantially increased by optimising the supramolecular and nanoscale structure of the active layer, and achieved the highest reported efficiency value (5.58%). The great efficiency improvement suggests that the design of innovative macromolecules can be supported by the development of a well-defined hierarchical architecture which takes into account the polymer supramolecular arrangement. Electrospinning has proven to be a promising technique for active material structure optimisation.

## INNATE IMMUNE RESPONSES TO HUMAN RESPIRATORY SYNCYTIAL VIRUS – EXPERIMENT AND MODELLING

Human Respiratory Syncytial Virus (RSV) is a ubiquitous negative-sense single-stranded RNA virus commonly responsible for acute pulmonary diseases in children and the elderly. Despite decades of research, no effective vaccine or treatment has been found and RSV remains the leading cause of lower respiratory tract infections in infants. As the host immune responses to RSV are considered an important part of the disease pathogenesis, we study the interactions between the virus and the pulmonary epithelial cells, in conditions resembling those of the early stages of the infection.

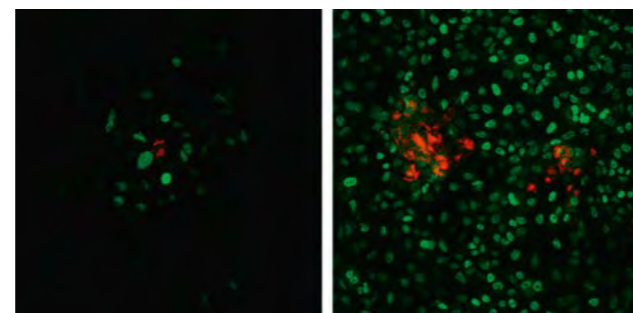


Fig. 4.1.2. Proliferation of RSV (red) and activation of STAT (green nuclear staining) via  $IFN\beta$  signaling; Confocal images 28 h (left) and 48 h (right) after infection

The research is aimed at elucidating how RSV interacts with and circumvents mechanisms of innate immunity in order to successfully replicate and spread throughout the population of A549 human lung epithelial cells. Studying fibroblasts responses to viral nucleic acid analogue, poly(I:C), we found that powerful positive feedbacks regulated by IRF3, NF $\kappa$ B and STAT pathways arise due to auto-/paracrine  $IFN\beta$  signaling. The paracrine signalling allows cells in the  $IFN\beta$ -primed subpopulations to switch to "virus-sensitive" state, characterized by elevated levels of virus-recognizing receptors and elements of positive feedback signaling. These cells would rapidly exhibit anti-viral responses and then commit apoptosis upon encountering the virus, limiting its options to replicate. However, RSV genome encodes two so-called nonstructural proteins (NS1 and NS2), which work specifically to disrupt interferon signaling at multiple stages, including both the cytokine's production as well as its sensing in target cells. Our initial results show that RSV is able to spread successfully in the A549 population, even if administered in low multiplicity of infection. Viral replication is accompanied by the activation of NF $\kappa$ B, IRF3, and by a significant production of  $IFN\beta$  at later stages of infection leading to STAT1 activation in cells neighboring the infection foci via paracrine signaling (see Fig. 4.1.2). The  $IFN\beta$  signaling slows the spread of infection, and  $IFN\beta$  pretreatment limits RSV replication to initially infected cells and halt the infection without resorting to apoptosis.

## HEMATOPOIETIC TRAVELING WAVES – MATHEMATICAL ANALYSIS

Haematopoiesis is a complex phenomenon leading to the formation and development of blood cells. It is intensively studied, for instance, in the context of various lethal diseases such as leukaemia. The process includes the evolution of undifferentiated haematopoietic stem cells (HSCs) which originate in the bone marrow before they become mature and enter the blood flow. The HSC cells can be divided into two

sub-populations: proliferating and quiescent ones. Both kinds of cells can diffuse in bones and die by apoptosis or undergo the following transformations:

1. quiescent cells can transit into the proliferating phase
2. at the end of the proliferating phase (of the length  $r$ ) each cell divides into daughter cells, which, with probability  $K$  remain in the proliferating phase, while with probability  $(1 - K)$  transit into the quiescent state.

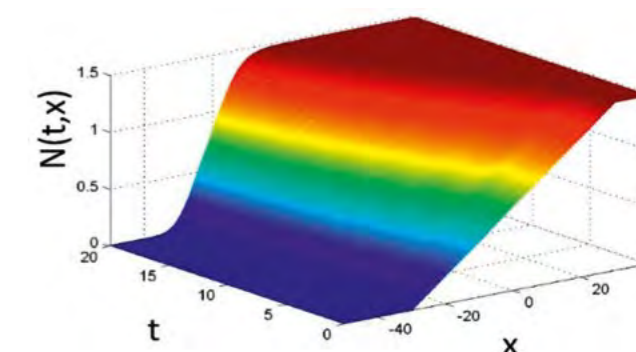


Fig. 4.1.3. The formation of the traveling wave solution  $N(x,t)$  from piece-wise linear initial condition

The death blood cells must be compensated by a continuous supply of new cells from the bone marrow. It is important to explain, how such a flux can be realized. Let  $n(t, x, a)$  and  $p(t, x, a)$  denote the concentrations of the quiescent cells and proliferating cells, where  $t$  denotes time,  $x$  position in space and  $a$  the cellular age. The equations for  $n$  and  $p$ , form an age-structured system with diffusion terms. It is interesting (and crucial for the analysis) that by the integration along the characteristics of the corresponding hyperbolic parts of these equations, one can arrive at a system composed of a nonlinear and nonlocal parabolic equation with delay and a difference equation with delay:

$$\frac{\partial N(t, x)}{\partial t} A = \frac{\partial^2 N(t, x)}{\partial x^2} - (\delta(N(t, x)) + \beta(N(t, x))) N(t, x) + 2(1 - K)e^{-\gamma r} \int_{-\infty}^{+\infty} \Gamma_2(r, x - y) u(t - r, y) dy$$

$$u(t, x) = \beta(N(t, x)) N(t, x) + 2Ke^{-\gamma r} \int_{-\infty}^{+\infty} \Gamma_2(r, x - y) u(t - r, y) dy,$$

where  $N(t, x) = \int_0^\infty n(t, x, a) da$ ,  $u(t, x) = p(t, x, 0)$ .

We have proved the existence of global in time solutions, as well as the existence of traveling wave  $(N(\xi), u(\xi))$  solutions where  $\xi = x + ct$ , and estimated the minimal speed of propagation. The study was published in J. Differential Equations, 2017.

### HYDRODYNAMIC INTERACTIONS OF MICRO AND NANO PARTICLES

In collaboration with Dr. Alexander Farutin and Prof. Chaouqi Misbah from Université Grenoble Alpes in France, we analyzed theoretically and numerically migration of flexible deformable elongated objects, fibers and vesicles, across Poiseuille flow of a viscous fluid at the low-Reynolds-number regime. We showed similarity of shape evolution of flexible fibers and vesicles (Fig. 4.1.4). We proved that these objects accumulate at a certain distance from the central plane of the flow, proportional to the characteristic ratio (called bending stiffness) of bending to hydrodynamic forces acting on deformable elastic objects.

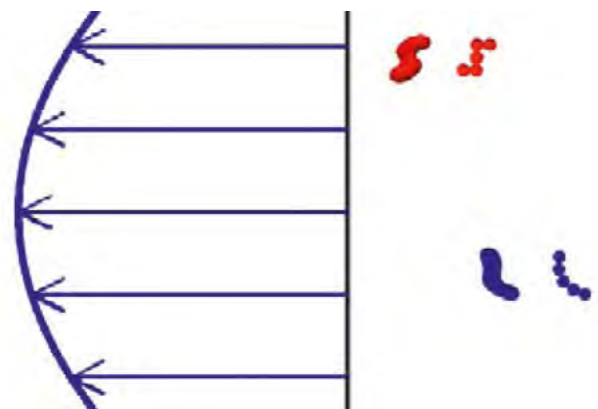


Fig. 4.1.4. Shapes of flexible fibers and vesicles in unbounded Poiseuille flow.

The results could be used to design new methods of sorting flexible objects, depending on their length and bending stiffness. Numerical computation of the dynamics of flexible fibers was based on the bead-spring model with resistance to bending, and the multipole method of solving the Stokes equations, implemented in accurate numerical codes Hydromultipole.

In cooperation with Prof. Bogdan Cichocki from the University of Warsaw, we analyzed theoretically Brownian dynamics of particles with complex non-spherical shapes, based on the Smoluchowski equation. Exact time-dependent analytical expressions were derived for cross-correlations of the translational and rotational Brownian displacements. This is the important generalization of the classical Einstein formula (valid for spherical particles) for the motion of non-spherical micro-particles at relatively short time scales, comparable with the characteristic time of the rotational self-diffusion.

Together with the research group of Prof. Krzysztof Kuczyra from the University of Kansas in USA, translational and rotational self-diffusion coefficients of peptides (NATA, WH5a, WH21, Gb1) were evaluated numerically using molecular dynamics, then compared with experimental results and applied to determine conformation of these peptides in fluids.

We also investigated theoretically and numerically the influence of the channel walls on the intrinsic viscosity

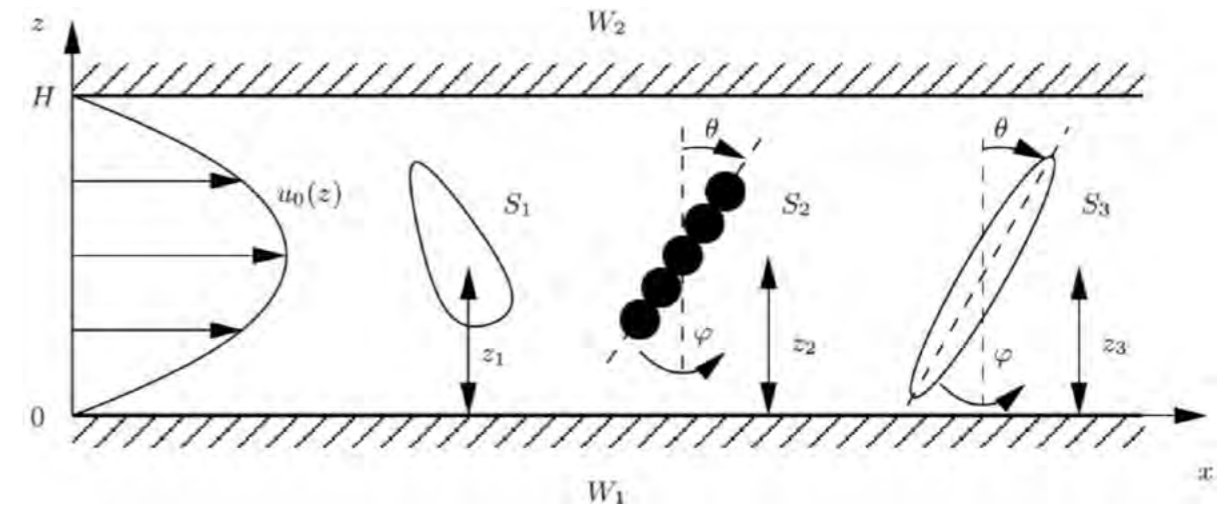


Fig. 4.1.5. Channel walls change suspension intrinsic viscosity

of a suspension made of elongated particles (Fig.4.1.5). Together with Prof. Jerzy Bławdziewicz from USA we performed computations for rigid rods made of touching beads, and showed a similar intrinsic viscosity dependence on the channel width as in case of prolate spheroids of the same aspect ratio, analyzed by our French collaborators Prof. Antoine Sellier and Prof. Francois Feuillebois. The channel was modelled as two parallel plane solid walls.

It is found that the intrinsic viscosity in bounded Poiseuille flow is generally smaller than the corresponding value in unbounded flow, except for extremely narrow gaps when it becomes larger because of lubrication effects. The intrinsic viscosity in shear flow is larger than in the Poiseuille flow, both between two walls. The intrinsic viscosity is at a minimum for a gap between walls of the order of 1.5–2 particle width.

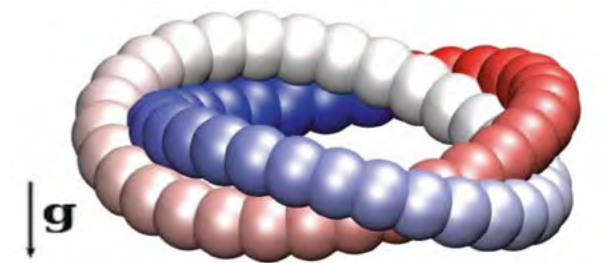
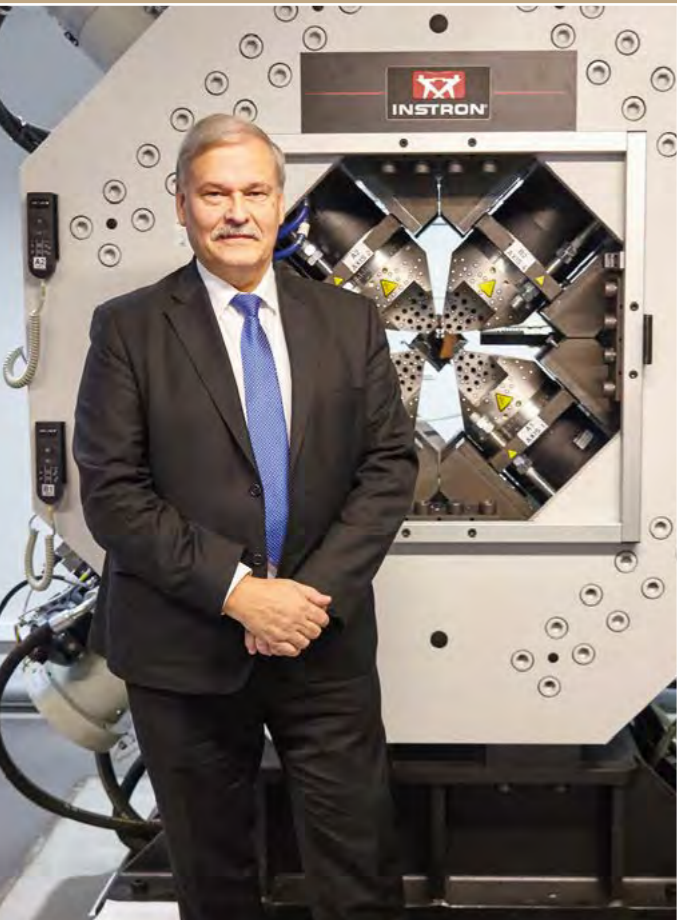


Fig. 4.1.6. Elastic trefoil filament sedimenting under gravity in a viscous fluid without inertia (numerical result). Authors from IPPT PAN: Magdalena Gruzziel, Tomasz Piasecki, Agnieszka Słowicka, Eligiusz Wajnryb, Maria Ekiel-Jezewska

Dynamics of elastic knotted closed filaments in a viscous Stokes fluid was investigated numerically. It was found that torus knots often attain a regular horizontal toroidal structure while sedimenting, with a number of intertwined loops, rotating and swirling periodically around each other (Fig.4.1.6). Together with Dr. K. Thyagarajan, Professors: G. Dietler, A. Stasiak from Lausanne and P. Szymczak from University of Warsaw, we found a remarkable agreement between numerical and experimental findings. The results may be used to determine structures of proteins and DNA.

## 4.2. DEPARTMENT OF EXPERIMENTAL MECHANICS



**Head:**  
Prof. Zbigniew L. Kowalewski

Secretary: Agnieszka Sokalska  
room: 133  
phone: +48 22 826 98 34  
+48 22 826 12 81 ext. 255  
e-mail: alyszk@ippt.pan.pl



The department has five divisions:

- Strength of Materials (Prof. Zbigniew L. Kowalewski)
- Applied Thermomechanics (Assoc. Prof. Elżbieta Pieczyska)
- Technological Laser Applications (Tomasz Mościcki, Ph.D., D.Sc.)
- Strain Fields (Prof. Michał A. Glinicki)
- Non-Destructive Testing (Assoc. Prof. Zbigniew Ranachowski)

### STAFF:

#### Professors

Prof. Michał A. Glinicki, Ph.D., D.Sc.  
Prof. Zbigniew L. Kowalewski, Ph.D., D.Sc.  
Prof. Zygmunt Szymański, Ph.D., D.Sc.

#### Associate Professors:

Elżbieta Pieczyska, Ph.D., D.Sc.  
Zbigniew Ranachowski, Ph.D., D.Sc.

#### Senior Researchers:

Justyna Chrzanowska-Giżyńska, Ph.D.  
Mariusz Dąbrowski, Ph.D.  
Jacek Hoffman, Ph.D., D.Sc.  
Daria Józwiak-Niedźwiedzka, Ph.D., D.Sc.  
Marcin Lewandowski, Ph.D.  
Tomasz Mościcki, Ph.D., D.Sc.  
Joanna Radziejewska, Ph.D., D.Sc.  
Przemysław Ranachowski, Ph.D., D.Sc.

#### Ph.D. Students

Damian Cacko, M.Sc.  
Karol Golański, M.Sc.

#### Retired

Prof. Andrzej Brandt, Ph.D., D.Sc.  
Prof. Lech Dietrich, Ph.D., D.Sc.

#### Technical staff

Aneta Antolik, M.Sc.  
Andrzej Chojnacki  
Tomasz Dębowski, M.Sc.  
Kinga Dziedzic, M.Sc.  
Karolina Gibas, M.Sc.  
Erwin Grzebielichowski  
Paweł Grzywina, M.Sc.  
Tomasz Katz, M.Sc.  
Mateusz Kopeć, M.Sc.  
Jan Kraskowski  
Dominik Kukła, Ph.D.  
Tomasz Libura, M.Sc.  
Sławomir Mackiewicz, Ph.D.  
Artur Myczka  
Rafał Psiuk  
Jakub Rozbicki  
Hanna Słomińska  
Maciej Sobczak  
Maria Staszczak  
Tomasz Steifer, M.Sc.  
Aneta Ustrzycka, Ph.D.  
Mateusz Walczak  
Jacek Widłaszewski, Ph.D.  
Beata Witek, M.Sc.  
Mirosław Wyszowski



The **Department of Experimental Mechanics (DEM)** is the experiment-oriented research group, with the following general objectives:

- to contribute to the further development of the Department as an internationally recognised research centre in advanced material testing and processing,
- to contribute to sustainable development of the Department in three complementary areas: fundamental research, research oriented to engineering problems, education and training,
- to build up networking activities of the Department with other worldwide research centres,
- to enhance the Department's involvement in joint worldwide research programmes,
- to build capacity of the Department as a potential research partner for the Polish industry and SMEs.

Furthermore, the Department organizes regular training courses and seminars devoted to various aspects of mechanics with special emphasis on the testing of mechanical properties of materials and structures.

In spite of an acute financial shortage for research in Poland, an experimental potential of the Department has recently strengthened in a significant manner. New testing equipment was purchased and installed, some experimental devices were modernised and laboratory compartments were renovated.

### THE DURABILITY OF CEMENT-BASED COMPOSITES IN AGGRESSIVE ENVIRONMENTS

The experimental and computational materials engineering research has been carried out on composite materials with porous, multiphase cement-based matrices, designed for long-term performance of structures in nuclear power or transportation engineering. Experimental studies have revealed that there is an influence of modified hydraulic binders and selected mineral aggregates on the resistance of concrete and other cement-based composites to aggressive environments.

Advanced materials characterisation methods were elaborated to support the identification of mineral components in aggregate grains prone to alkali-silica reaction (Fig. 4.2.1) leading to internal cracking. Calorimetric test methods and the inverse analysis of heat transfer were applied to characterise the heat generation and the temperature field during setting and early-hardening of cementitious binders. The evolutionary computational procedures were developed for the identification of thermophysical properties of hardening concrete in massive structures.

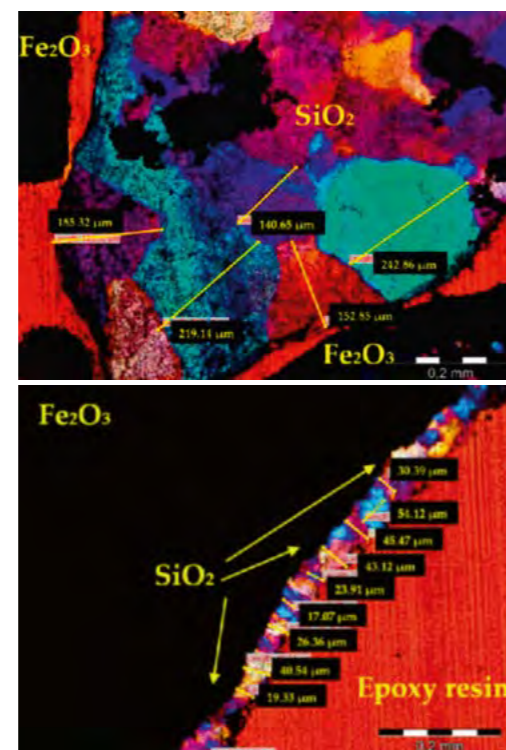


Fig. 4.2.1. Quartz grain size in hematite aggregate revealed using digital image analysis: (a) innocuous, (b) reactive

It has been found that the permeability of radiation-shielding concrete is strongly influenced by the degree of water saturation of capillary pores. For the meaningful evaluation of air-permeability, original procedures were proposed, of accelerated drying with simultaneous measurement of moisture distribution in concrete specimens. The effects of heavyweight and hydrogen-bearing aggregates on the chloride ion permeability and the rate of water absorption have been revealed.

As shown in Fig. 4.2.2, the influence of matrix modification with calcareous fly ash on the pore-size distribution in low-clinker matrices has been found. It has also been observed that the rate of aggressive ion diffusion in cement-based composites was strongly related to the content of capillary pores with the diameter range from 0.1 to 1 µm.

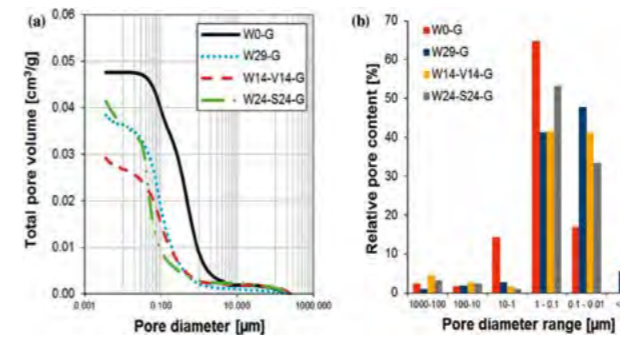


Fig. 4.2.2. Pore size distribution in cement-based composites modified with calcareous fly ash

### COMPRESSION TESTS OF THIN METAL SHEETS ENABLING DEFORMATION UP TO 10% WITHOUT THE BUCKLING EFFECT

The compression-tension test fixture created by DSM enables to avoid buckling during the compression of specimens made of thin metal sheets. The main characteristic of the device is that it changes its length while a specimen elongates or shortens. During the test, the friction force which is generated due to the movement of both parts of the fixture is measured by a special strain gauge system. This particular device is adaptable to the MTS tension-compression frame.



Fig. 4.2.3. A photograph of the device ready to work

### DAMAGE DEVELOPMENT ASSESSMENTS DURING FATIGUE/CREEP SUPPORTED BY ESPI AND DIC

This turned out to be an original approach to damage assessments, as both the mechanical investigations for strength parameter determinations and the non-destructive testing for acoustic or magnetic parameters identification may be carried out in parallel.

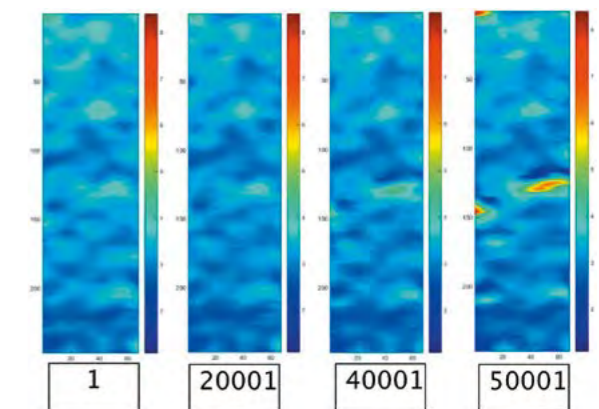


Fig. 4.2.4. Strain maps of nickel super-alloy for the selected numbers of cycles

Such performance of the testing programmes provides an opportunity to find a mutual correlation between both types of parameters for a range of deformation processes taken into account. Moreover, the observations on the microscopic level of tested materials may be conducted for various degrees of damage. It also provides an additional opportunity for the damage analysis, namely, for the assessment of mutual correlation between macro and micro parameters. The damage development analysis implemented full-field optical techniques such as ESPI and DIC.

The experimental data collected during tests have created a comprehensive source of knowledge stimulating theoretical analyses in the field of constitutive modelling of material behaviour under multiaxial stress states following various types of prestraining.

### DYNAMIC INVESTIGATIONS OF MATERIALS OVER A WIDE RANGE OF STRAIN RATES

DEM provides one of the most popular experimental techniques applied in the determination of viscoplastic properties of materials at strain rates ranging from  $\sim 5 \cdot 10^2 \text{ s}^{-1}$  to  $\sim 10^4 \text{ s}^{-1}$ , the so-called *Split Hopkinson Pressure Bar* (SHPB). In the testing stand for this technique, a wafer specimen is placed between bars, Fig. 4.2.5. The laboratory in DEM also provides a dynamic stand for tensile tests, Fig. 4.2.6.

The miniaturized Direct Impact Compression testing stand enables to increase a range of strain rates to be measured up to  $10^5 \text{ s}^{-1}$ . The stand was elaborated at DEM and subsequently patented. The modification in the mechanical part lies in the introduction of

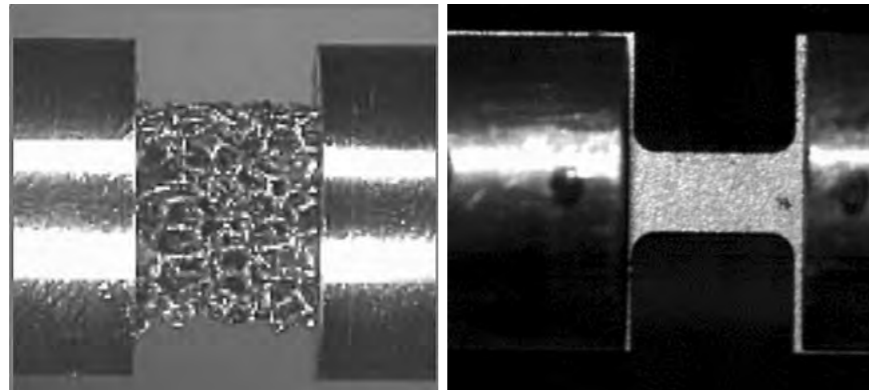


Fig. 4.2.5. Specimen under dynamic compression

Fig. 4.2.6. Specimen under dynamic tension

a decelerator tube in which a small Hopkinson bar with miniature SR gages was inserted. Thus, an original and inexpensive optical technique has been applied to measure the displacement of the interface striker-specimen. The combination of a quasi-static precision compression test, along with the application of SHPB and the miniaturized DICT, has made it possible to determine the rate sensitivity of materials for a very wide strain rate spectrum, from  $5 \times 10^{-4} \text{ s}^{-1}$  to  $5 \times 10^4 \text{ s}^{-1}$ .

### MATERIALS TESTING UNDER MULTIAXIAL STRESS STATES USING THIN-WALLED TUBULAR AND CRUCIFORM SPECIMENS

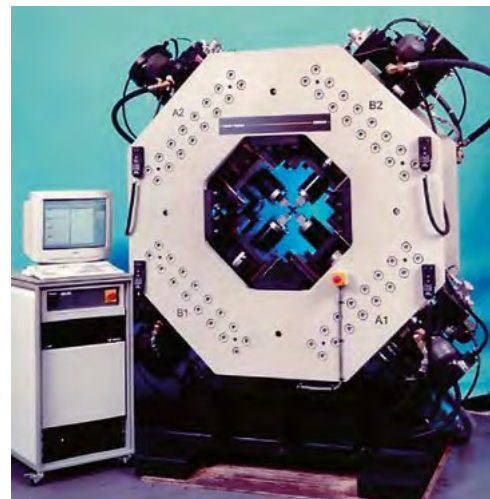


Fig. 4.2.7. Stand for cruciform specimens testing

DEM was equipped with servo-hydraulic testing machines enabling tests under complex stress states and being the combination of axial force, twisting moment and internal pressure or the combination of two axial forces mutually perpendicular.

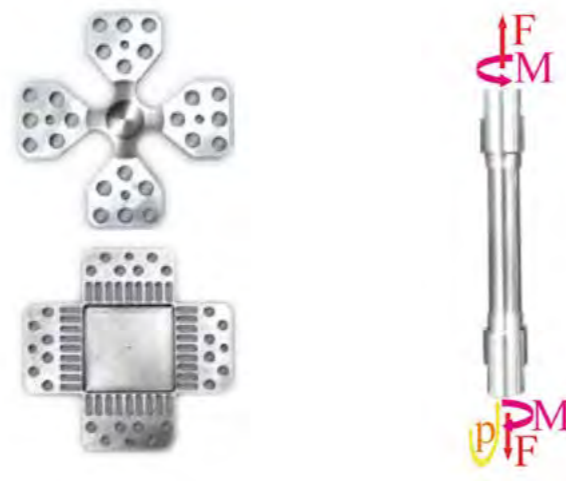


Fig. 4.2.8. Specimens for tests under complex stress states

### DEPOSITION OF SUPER-HARD THIN FILMS

Tungsten borides belong to the group of potentially super-hard materials whose hardness could be compared to cubic boron nitride and diamond. The objective of this investigation was the deposition of tungsten borides layers by laser pulse and magnetron sputtering in order to find the relationship between the deposition parameters, the internal structure of the material and its properties. Hitherto  $W_2B$ - $\beta$ WB,  $\alpha$ WB-WB-WB<sub>3</sub>, WB<sub>3</sub>, and boron layers were deposited by laser pulse. Moreover, single phase  $\alpha$ WB layers were deposited by magnetron sputtering. WB<sub>3</sub> and  $\alpha$ WB layers were investigated in the indentation test at a load of 5-30 mN and their hardness was up to 50 and 70 GPa, respectively.

### PULSED LASER ABLATION IN LIQUID (PLAL)

It is a widely recognized method of synthesizing the contamination-free nanostructures, especially nanoparticles such as Fluorescent Carbon Nanoparticles (FCNPs), carbon polyynes etc. Most of the attention has been given to fluorescent nanoparticles, especially to those with diameters of 2 to 8 nm called Carbon-Dots, which are widely used for fluorescent imaging, mainly of cells and tissues. Their most remarkable property is the emission of excitation-dependent fluorescence. The laboratory of the Division of Technological Laser Applications performed the synthesis of nanoparticles by laser ablation in various liquids, such as: deionized water, isopropyl alcohol (IPA), acetone and PEG200. The carbon nanoparticles synthesized in all these liquids, with the exception of water, exhibited considerable fluorescent emission.

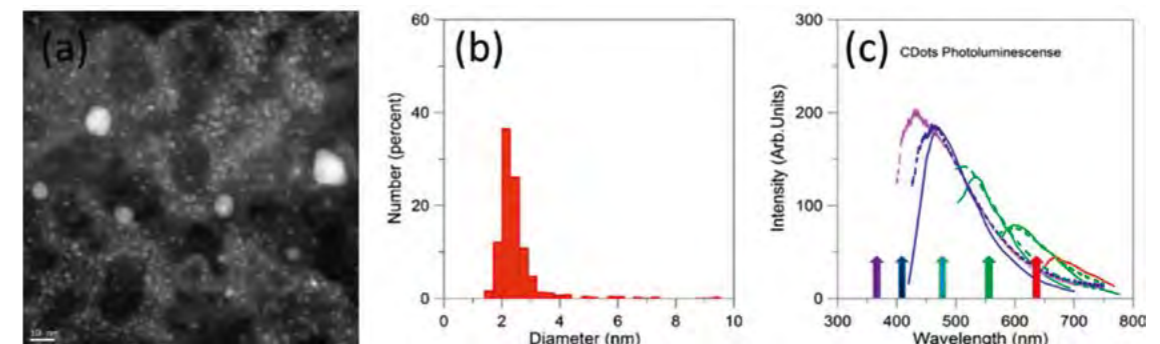


Fig. 4.2.9. HRTEM image (a), particle size-distribution derived from the HRTEM image (b), and photoexcitation and photoluminescence spectra (c); excitation wavelengths are indicated by arrows; solid line - inverted confocal microscope, broken line - fluorescent microscope

### IMAGE PROCESSING PROCEDURES TO ASSESS THE MICROSTRUCTURE OF FIBRE CEMENT BOARDS

The ongoing research in the Laboratory is being conducted under the cooperation with the Faculty of Civil Engineering, at Wrocław University of Technology - delivering the specimens of industrial fibre cement boards used as a façade covering in building technology. The micro computed tomography (micro-CT) is being used to study the microstructure of this material.

The main goal of the research has been to obtain 3D images of the microstructure of the examined composite and to visualise the fibres network in the boards of different quality. Black regions depicted in Fig. 4.2.10 denote low density regions of single fiber or fiber agglomerates. The real dimensions of the cubes are 5 x 5 x 5 mm.



Fig. 4.2.10. Three-dimensional view of three specimens cut off the boards of different quality

A special image processing technique has made it possible to visualize the location of fibres in presented specimens. It was achieved by comparing the brightness of adjacent voxels (i.e. 3D pixels) in order to find low density regions. The original software was designed to visualize the interconnection of agglomerates by examining the datasets resulted in micro-CT scanning.



Fig. 4.2.11. Visualisation of fibres in presented specimens performed by examining the datasets resulted in micro-CT scanning

It is also now possible to alternatively present the same data in the form of greyscale histograms where the frequency of the occurring of voxels differs in brightness, as depicted. The latter method can be applied to compare relative density of fibre boards made with using various technologies.

**NEW MULTIFUNCTIONAL MATERIALS  
- THERMOMECHANICAL  
AND LOCALIZATION EFFECTS**

The research concerns the investigation of unconventional mechanisms of the new materials deformation, basing on the effects of thermomechanical couplings. Mechanical characteristics are obtained by testing machine and digital image correlation (DIC). The material-related temperature changes are captured by a sensitive IR infrared camera. By comparison of the stress-strain curves, the strain distribution determined by DIC, the temperature distribution obtained by IR and the microstructure, the new material deformation mechanisms are analyzed at various stages of the loading. The experimental and theoretical research is conducted within the international cooperation; the materials are purchased from Japan. A constitutive model considering mechanical parameters and temperature changes was proposed and verified by experimental results. Here is an example of the result obtained for two smart materials: Gum Metal and shape memory polymer (SMP), as shown in Fig. 4.2.12 and Fig. 4.2.13.

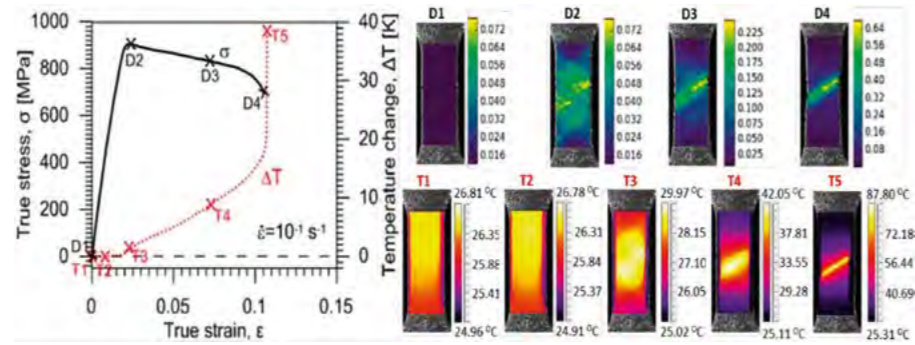


Fig. 4.2.12. Stress and temperature change vs. strain during tension of Gum Metal at strain rate of  $10^{-1} \text{ s}^{-1}$  with thermal (T1-T5) and strain (D1-D4) distributions captured at selected points

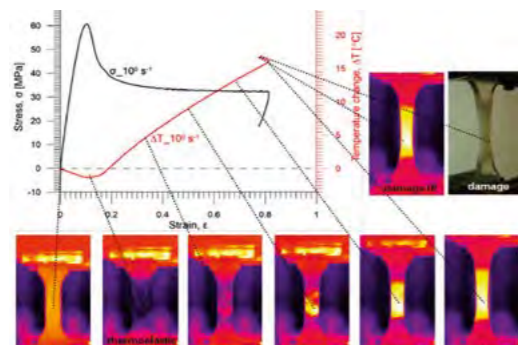


Fig. 4.2.13. Stress and temperature change vs. strain for SMP tension at strain rate  $10^0 \text{ s}^{-1}$  completed by thermal images of the specimen corresponding to different loading stages

**4.3. DEPARTMENT OF INFORMATION  
AND COMPUTATIONAL SCIENCE**



Head:  
Assoc. Prof. Piotr Kowalczyk

Secretary: Zofia Grzechnik  
room: 426  
phone: +48 22 826 96 15  
+48 22 826 12 81 ext. 164  
e-mail: zgrzech@ippt.pan.pl

The department has two divisions:

- Computational Methods in Nonlinear Mechanics (Prof. Jerzy Rojek)
- Computational Materials Science (Prof. Paweł Dłużewski)

and one research group

- Computational Analysis of Advanced Structures (Prof. Krzysztof Wiśniewski)



**STAFF:**

**Professors**

Prof. Tadeusz Burczyński, Ph.D., D.Sc.  
Prof. Paweł Dłużewski, Ph.D., D.Sc.  
Prof. Michał Kleiber, Ph.D., D.Sc.  
Prof. Krzysztof Wiśniewski, Ph.D., D.Sc.

**Associate Professors**

Piotr Kowalczyk, Ph.D., D.Sc.  
Prof. Jerzy Rojek, Ph.D., D.Sc.

**Senior Researchers**

Dmytro Lumelskyj, M.Sc.  
Szymon Nosewicz, Ph.D.  
Toby Young, Ph.D.

The main research areas of the Department are information science and computational science. Our research activities are to a large extent interdisciplinary — they cover informatics, mathematics and a number of disciplines that embrace the particular areas of application of the research, such as mechanics, biomechanics, etc. The universal character of computational methods and algorithms, based mainly on the finite element method (FEM), as well as on a number of other contemporary and novel numerical methods, allows us to undertake a wide spectrum of research challenges, frequently in cooperation with other research institutions from Poland and other foreign countries.

For the last two years, our research activities have concentrated on the following areas.

**PARTICLE BASED MODELLING OF MATERIALS AND MATERIALS PROCESSING**

Particle-based methods have recently become a very powerful tool for the numerical modelling of various natural and manufactured materials such as powders, granular materials, soils, rocks, ceramics and concrete. A typical numerical method employing particles is the discrete element method (DEM). In the DEM, a material is represented by a large assembly of particles (discrete elements) interacting with one another by contact forces. The DEM offers significant advantages over continuum-based methods, such as the finite element method. The particle model, in a simple way,

**Ph.D. Students**

Piotr Jarosik  
Nikhil Madan, M.Sc.  
Michał Marijnissen, M.Sc.  
Sangeeth Saseendran, M.Sc.

**Technical staff**

Grzegorz Jurczak, Ph.D.  
Marcin Maździarz, Ph.D.  
Eligiusz Postek, Ph.D., D.Sc.  
Piotr Tazowski, Ph.D.

**Retired**

Krzysztof Doliński, Ph.D., D.Sc.  
Prof. Witold Gutkowski, Ph.D., D.Sc.

takes into account discontinuities, either existing in the material, or appearing under an applied loading. New DEM algorithms have been implemented in an 'in-house' DEM/FEM computer program which can be applied to simulate real-life problems in many branches of industry.

**Modelling of rock mechanics problems**

Typical applications of the developed DEM models are in the field of rock mechanics and rock excavation (Fig. 4.3.1). An original thermomechanical model for rock cutting has been developed. The new formulation takes into account thermal effects and wear of rock cutting tool. This analysis makes it possible to predict

and optimise excavation processes in mining and civil engineering. The models of brittle failure of rock-like materials have been used to simulate comminution of copper ore (Fig. 4.3.2).

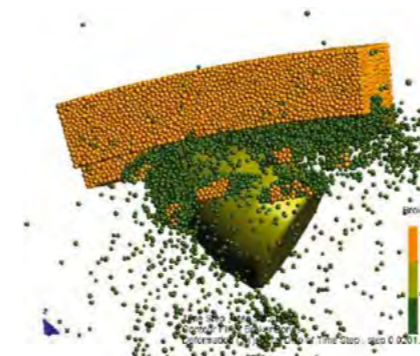


Fig. 4.3.1. DEM simulation of rock cutting in underground excavation

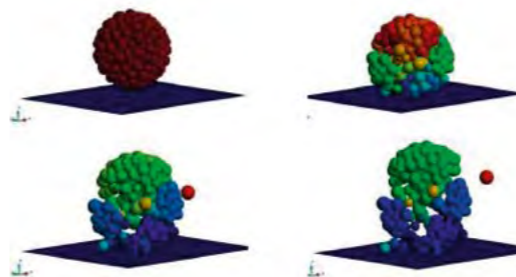


Fig. 4.3.2. DEM simulation of the comminution of copper ore

**Modelling of powder metallurgy processes**

A new original viscoelastic model of sintering has been developed and applied to the analysis and optimisation of manufacturing of advanced metal-ceramic composite materials (Fig. 4.3.3). The DEM models make it possible to analyse effects both at the micro- and macroscopic scales — a multi-scale framework for modelling of powder sintering has been developed.

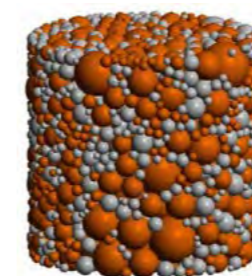


Fig. 4.3.3. DEM model of metal-ceramic composite

**Simulation of particle and mixed fluid-particle flows**

The discrete element method is suitable to model particle flow. When coupled with the CFD simulation algorithm, it can be applied to simulate mixed fluid-particle flow. Such model has been used to analyse and optimise the air flow with solid particles in a beater mill for comminution of copper ore (Fig. 4.3.4).

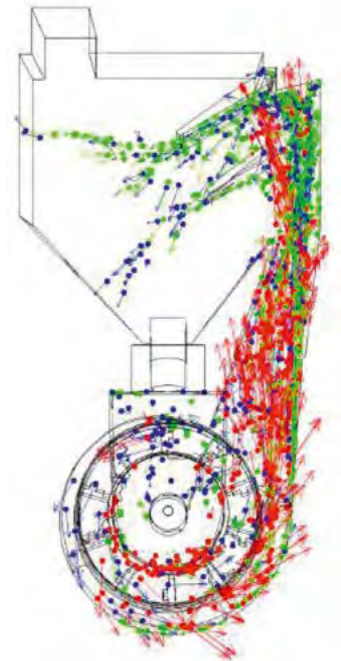


Fig. 4.3.4. Coupled CFD-DEM simulation of the fluid-particle flow in a beater mill

**COMPUTATIONAL DESIGN OF 2D NANO-MATERIALS BASED ON CARBON**

New potentially 2D graphene-like materials are generated by the two-stage searching strategy combining molecular and ab-initio approaches. In the first stage, two candidates, X and Y, are obtained using a molecular model and the memetic-based algorithm combining the evolutionary algorithm and the conjugate-gradient optimisation technique. The main goal of the optimisation is to find stable arrangements of carbon atoms under certain imposed conditions (e.g. density, shape and size of the unit cell). The fitness function is formulated as the total potential energy of an atomic system. The optimised structure is considered as a discrete atomic model and interactions between atoms are modelled using the AIREBO potential, specifically developed for carbon and hydrocarbon materials.

The parallel approach used in computations allows significant reduction of computation time. The obtained results and examples of the models of the new 2D materials X and Y obtained using the described algorithm are validated along with their mechanical properties.

In the second stage, the two candidates, X and Y, are then deeply analysed using first-principles Density Functional Theory from the mechanical, structural, phonon and electronic properties point of view. The tests have shown that both proposed polymorphs of graphene X and Y are mechanically and dynamically stable and can be metallic-like (Fig. 4.3.5).

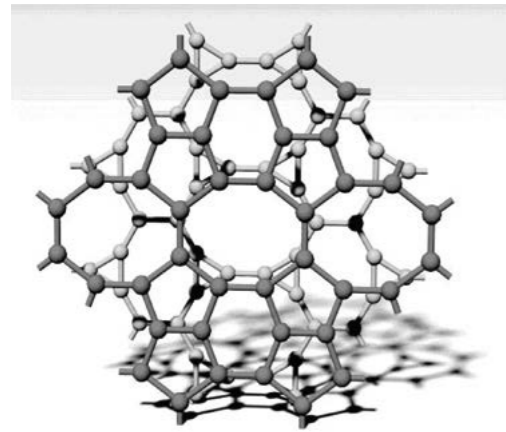


Fig. 4.3.5. New graphene X

Optimal searching for the new stable atomic arrangements of two-dimensional graphene-like carbon lattices with predefined mechanical properties are also considered using the described memetic method. The main goal of the optimisation is to find stable arrangements of carbon atoms placed in the unit cell with imposed periodic boundary conditions, which reveal desired mechanical properties. Two examples of the newly obtained models of the flat carbon materials are obtained. Their mechanical properties are additionally validated during the simulation of the tensile tests using molecular dynamics. At present, both new 2D materials with predefined mechanical properties are analysed using the first-principles DFT.

### CONTINUUM AND ATOMISTIC MODELLING OF COUPLED FIELDS IN CRYSTALLINE HETEROSTRUCTURES

A various-type couplings of the elastic, chemical and electric fields, as well as the inelastic deformation induced by phase transition, are analysed at the nanoscale by means of the continuum, atomistic and/or ab-initio methods.

The effect of both, nonlinear piezoelectricity (elastostriction) and threading dislocation (TD) on the physical and optoelectronic properties of GaN/AlN quantum dots (QD) has been modelled in terms of finite deformation approach. Edge-type threading dislocations, common for III-nitride epitaxial layers, due to the local elastic field around dislocation line, not only reduce residual strains in quantum dots but also partially compensate the red shift of the band-to-band transition energy related to the electrons clustered on broken atomic bonds along dislocation line. The main goal of this analysis was to determine the qualitative and quantitative effect of such phenomena on physical and optoelectronic properties of quantum structures in III-nitrides.

A new subject has been undertaken. It concerned the finite element analysis of the residual stresses induced by precipitation of hexagonal-type MnAs particles in the magnetic shells of wurtzite-type GaAs-based nano-wires.

An extensive analysis of potentially new single-atom thick 2D-graphene-like materials has been carried out within the framework of first-principles density functional theory from the viewpoint of structural, mechanical, electronic and phonon properties. The next task concerned the analysis of potentially superhard tungsten borides WBx. Polymorphs of ReB<sub>2</sub> were calculated from first principles. An atomistic modelling of self-diffusions in NiAl and Al<sub>2</sub>O<sub>3</sub> crystals was performed by means of molecular dynamics. Such determined diffusivity was then used for the discrete element analysis of sintering.

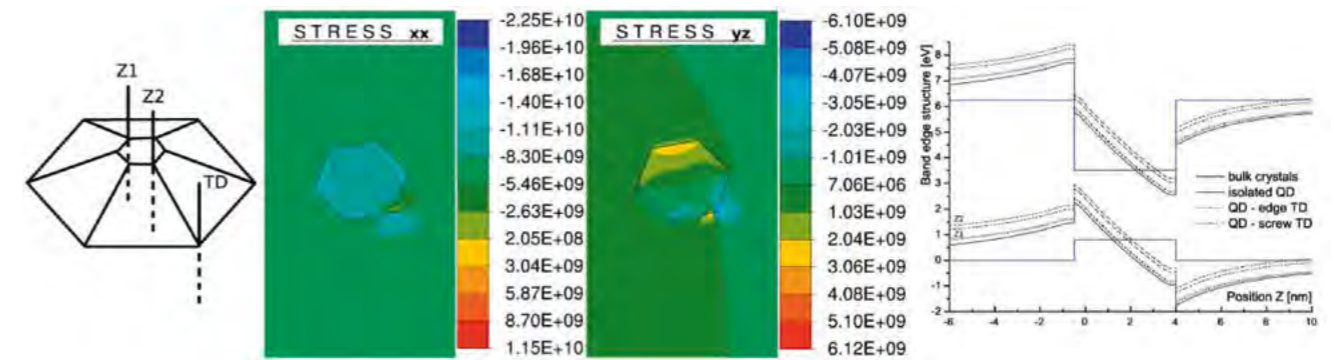


Fig. 4.3.6. The wireframe scheme of the QD with TD location, stress distribution in the case of edge-type (left panel) and screw-type (right panel) dislocation, estimation of the band edge structure of the heterostructure

### APPLICATION OF PARALLEL AND DISTRIBUTED ALGORITHMS TO INCREASE EFFICIENCY OF THE FINITE ELEMENT METHOD

The computation of large boundary value problems in the mechanics of 3D bodies and shell-like structures using the Finite Element Method depends on the effective use of multi-core processors and a cluster of computers. Improvements are proposed in two areas of the FE code: the loop over elements and the solvers of a linear system of equations.

The proposed multithreaded algorithm of parallelisation of the loop over elements and the reduction of elemental matrices to the global matrix using OpenMP has efficiency around 95%. It was implemented in a complex academic code FEAP.

Concerning the multithreaded solvers for one computational node, several improvements are proposed for the HSL MA86 sparse parallel solver, which speed up computation by about 11.5% and scalability by about 6.5%. The mixed precision version of this solver is developed, with factorisation in single precision and iterative refinement in double precision, speeding up computations by 2.17 times and providing the scalability of 10.28 on 12 cores.

To further improve the effectiveness of solving a system of linear equations, a distributed solver for a cluster is developed using MPI. It is based on the domain decomposition and the computation of the Schur complement by par-

tial factorisation in the HSL MA86 solver, which makes the computations on nodes very efficient. Still, factorisation of the interface matrix is a bottleneck, even for HSL MA64, which is the fastest of several solvers tested for dense matrices.

To speed up factorisation, the use of two other techniques is proposed: the hierarchical factorisation and the mixed precision with iterative refinement. The total speedup achieved by Solver 3, using OpenMP and MPI, on 8 nodes 12 cores each, is about 36 times (see Fig. 4.3.7.), and is better than the speed up of the professional solver WSMP. For comparison, the FETI-DP method, using direct methods in domains and the iterative PCG solver for the interface equations, is implemented.

The developed algorithms are tested on FE models of a homogeneous cube and of two materials with a complicated microstructure: a corundum foam and a metal-ceramic composite. The biggest model computed has over 30 millions unknowns. Tests prove that the implemented algorithms are of a very good quality.

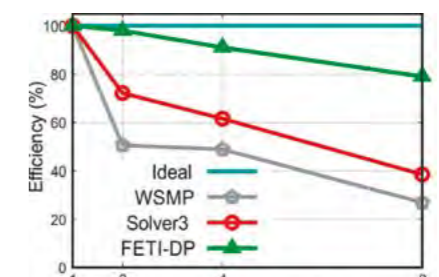


Fig. 4.3.7. Weak efficiency of Solver 3 for the corundum foam. Tasks of size 3.8, 7.6, 15.2 and 30.4 millions of unknowns are solved on 1, 2, 4 and 8 computational nodes

## 4.4. DEPARTMENT OF INTELLIGENT TECHNOLOGIES



**Head:**  
**Assoc. Prof. Łukasz Jankowski**

Secretary: Zofia Grzechnik  
room: 426  
phone: +48 22 826 96 15  
+48 22 826 12 81 ext. 164  
e-mail: zgrzech@ippt.pan.pl

The department has two divisions:

- Safety Engineering (Assoc. Prof. Łukasz Jankowski)
- Control and System Dynamics (Prof. Czesław Bajer)

and research group:

- Intelligent Systems (Jacek Szklarski, Ph.D.)



### STAFF:

#### Professors

Prof. Czesław Bajer, Ph.D., D.Sc.  
Prof. Jan Holnicki-Szulc, Ph.D., D.Sc.

#### Associate Professors

Łukasz Jankowski, Ph.D., D.Sc.  
Miroslaw Meissner, Ph.D., D.Sc.  
Tomasz Szolc, Ph.D., D.Sc.

#### Senior Researchers

Janusz Będkowski, Ph.D.  
Bartłomiej Dyniewicz, Ph.D., D.Sc.  
Cezary Graczykowski, Ph.D.  
Dominik Pisarski, Ph.D.  
Jacek Szklarski, Ph.D.  
Tomasz Szmidt, Ph.D.  
Maciej Zawidzki, Ph.D.  
Tomasz Zieliński, Ph.D., D.Sc.  
Andrzej Ziółkowski, Ph.D., D.Sc.

#### Retired

Prof. Roman Bogacz, Ph.D., D.Sc.  
Prof. Adam Borkowski, Ph.D., D.Sc.

#### Technical staff

Bartłomiej Błachowski, Ph.D.  
Jan Całka  
Krzysztof Kaźmierczak, Ph.D.  
Robert Konowrocki, Ph.D.  
Grzegorz Mikułowski, Ph.D.  
Anita Orłowska, Ph.D.  
Piotr Pawłowski, Ph.D.  
Grzegorz Suwała, Ph.D.  
Magdalena Struska, B.Sc.  
Andrzej Świercz, Ph.D.  
Rafał Wiszowaty, Ph.D.  
Zbigniew Wolejsza, Ph.D., D.Sc.

#### Ph.D. Students

Rami Faraj, M.Sc.  
Krzysztof Fedor, M.Sc.  
Michał Gawlicki, M.Sc.  
Maja Gębik-Wrona, M.Sc.  
Sylwester Kostro, M.Sc.  
Maciej Michajłow, M.Sc.  
Kamil Opiela, M.Sc.  
Mariusz Ostrowski, M.Sc.  
Błażej Popławski, M.Sc.  
Michał Rak, M.Sc.  
Maciej Wasilewski, M.Sc.

Our research interests are focused on the field of smart systems, structures and technologies. This is a relatively new interdisciplinary research area that combines structural engineering, control theory, vibroacoustics and mobile robotics. The keyword that best describes our activity is: adaptivity—the nature-inspired capability of dynamic self-assessment and optimum self-adaptation to varying external conditions. The research also includes a strong component of sensor and actuator technologies, computational intelligence, decentralized processing and data fusion techniques.

Although our main mission is to conduct fundamental research, a number of obtained results provide a direct application-related context, especially in the areas of small aviation and space industry or in energy and power systems.

## DAMAGE DETECTION AND STRUCTURAL HEALTH MONITORING

The safety of civil infrastructure is of critical importance for the society. The infrastructure must be thus constantly maintained, especially as many structures are currently reaching the end of their design lives. Recent trends in civil engineering involve structural health monitoring (SHM) of large-scale engineering structures such as bridges, buildings or telecommunication towers, and in the last two decades, many computationally intensive methods for damage detection have been proposed.

We are active in a number of SHM-related problems, including sensing technology, signal processing algorithms, high-level data interpretation and local, substructure-level monitoring. The ultimate aim is to develop robust methodologies for damage detection and localization, which are capable to deal with real-world complex engineering systems.

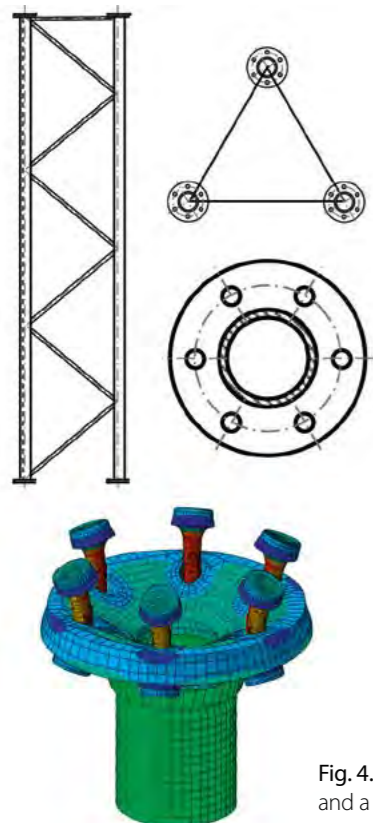


Fig. 4.4.1. Steel tower segment and a flanged connection

## HIGH ALTITUDE PSEUDO SATELLITE (HAPS)

Nowadays, there is a large interest in stratospheric platforms able to operate on high altitude (approx. 20 km) and deliver services similar to those provided by satellites, but at a much lower price and better quality.

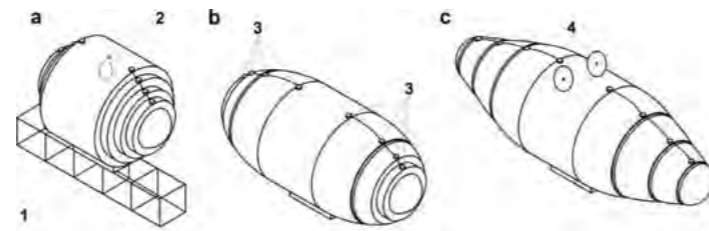


Fig. 4.4.2. Self-deployable, adaptive airship system for automatic climbing up and descent (patent pending)

Our investigations are focused on new Polish technologies necessary to design an original stratospheric airship able to perform monitoring and telecommunication functions. We focus on a self-deployable system for automatic adjustment of HAPS volume (retaining the shape) when climbing up and setting down, and in particular, on an adaptive, self-deployable technique for vertical mobility of HAPS, including: the concept in response to a technological challenge, the general concept of HAPS self-deployment and AERO-FIX installations, simulations of pressure-control-based vertical mobility, piezo-triggers for self-deployment and control system, dynamic stabilization of structural response to environmental excitations, design and assembly of an UAV-aerostat demonstrator, wind-tunnel and lab tests of the demonstrator and field tests for the anchored demonstrator.

## DYNAMICS OF ROTATING MACHINERY AND ELECTRO-MECHANICAL COUPLING OF VIBRATIONS

Currently, there is a significant increase in nominal rotational speeds of rotating machinery, which can reach up to 100,000 rpm. Such speeds require innovative technologies, as well as advanced computer

models of rotor dynamics and efficient monitoring and diagnostic techniques. Our investigations are focused on the identification of dynamic unbalances. The main objects of research are high-speed rotor-shafts of turbochargers, beater mills and crushers, and their drive systems. For instance, we supported the design of a high-speed beater mill adopted to copper ore grinding with intensive static and electrodynamic analyses, which, in consequence, allowed the building of a prototypical installation for high-energy ore preparation. This installation includes a new diagnostic system.



Fig. 4.4.3. Prototype of high-speed mill of copper ore

Transient and steady-state operation of drive systems is significantly influenced by the electro-mechanical coupling between the mechanical vibrations of the shaft system and the electrical vibrations in the driving motor windings. We simultaneously consider the dynamic behaviors of the mechanical and electrical parts for effective minimisation of oscillation amplitudes and total energy consumption.

## ADAPTIVE DAMPING OF VIBRATING STRUCTURES

Adaptive or self-adaptive technologies are efficient in control of vibrating structures. In practice, these modern technologies can be applied to reduce harmful vibrations from different sources that are transmitted to buildings, vulnerable historical sites and bridges. They are also used in robotics where a high precision of fast motion is required. Another aim is to control and act intentionally on certain elements of complex systems in extreme incidents to reduce the destructive effects. A layer of an intelligent material with a specific characteristic behavior can decrease deformations, so that such intelligent materials can often replace typical controlled dampers. The proposed novel type of a pneumatic device filled with granular material is a good example. The granular material is used to implement a switched control strategy in order to stabilize the vibration of a slender structure. The deformable granular coupler semi-actively damps an initially deflected pair of adjacent aluminum beams or in practice twin buildings. Although the approach is conceptually simple, its operational simplicity and low cost should attract the attention of engineers who seek solutions that can be used to build new structures and upgrade existing ones.

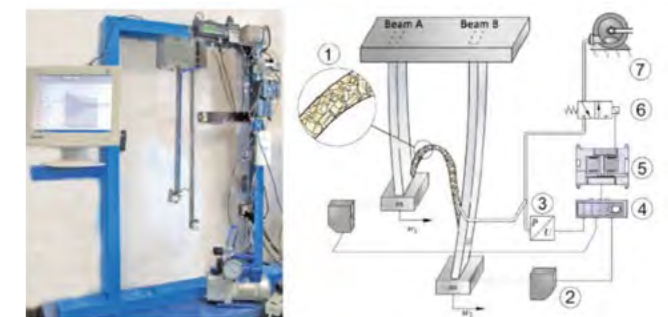


Fig. 4.4.4. Control of structure by a damper with granular material

## POROACOUSTICS AND VIBROACOUSTICS

We are active in the research on poroacoustics and vibroacoustics, which involves theoretical, numerical and experimental investigations concerning acoustic wave propagation and absorption in porous and poroelastic media. In particular, to determine effective macroscopic scale models, we use microstructure-based modelling which involves homogenisation techniques applied for periodic micro-geometries of porous media. The ultimate goal is to design novel sound absorbing materials. For experimental validation, 3D printing is used to manufacture samples with designed micro-geometries. The vibroacoustic research involves active, passive and adaptive systems for acoustic insulation and noise reduction, involving porous and poroelastic materials, as well as piezoelectric materials.

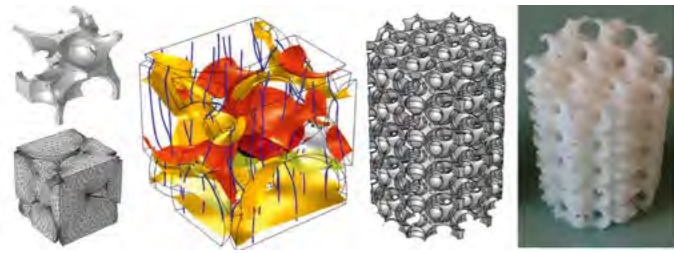


Fig. 4.4.5. A randomly generated periodic Representative Elementary Volume of skeleton with open porosity, the finite element mesh on the corresponding fluid domain and some results of microstructure-based finite element computations, finally, the periodic geometry and 3D-printed sample used in experimental investigations

## ADAPTIVE AIR BAG SYSTEM (ADBAG)

Currently available drones/UAVs are not equipped with any anti-crash protecting systems. Some companies have started to equip them with parachute systems. We develop an airbag-based AdBag system to protect a drone/UAV and its expensive electronic equipment against destruction during ground crash, as a safe emergency landing system alternative to a parachute. The activity is focused on the development of an innovative „AdBag” device as the landing gear which provides significant improvement of the shock-absorbing process (impact prediction and identification, simulations, controlled and tuned shock absorption, no rebounding). AdBag technologies include: inflation system, appropriate sensors, release valve system and controller. These technologies can be scaled-up and used successfully with ultra-light and small aircrafts (GA).

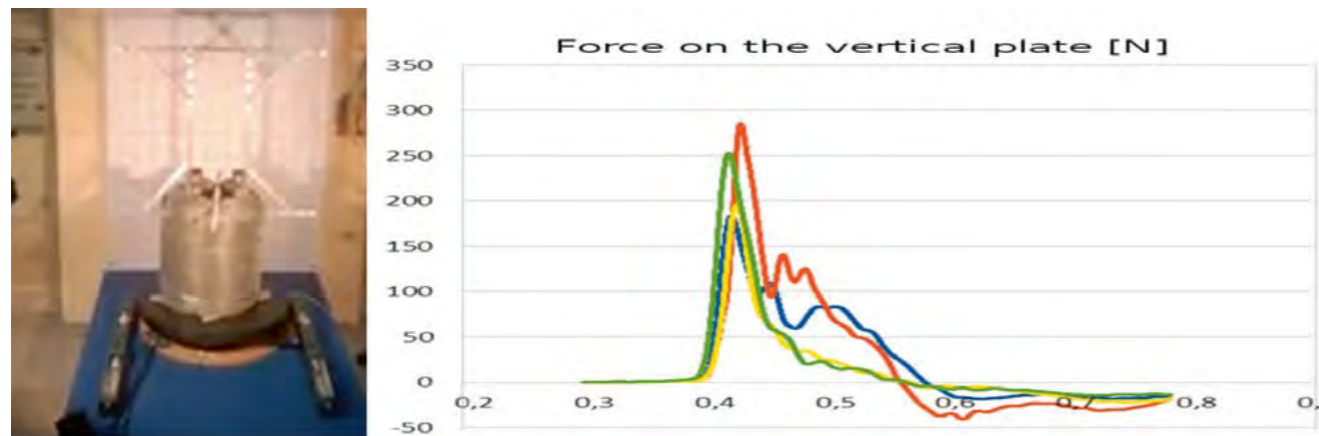


Fig. 4.4.6. Drop tests of the airbag system in IPPT PAN and the measured forces vs. time

## EXTREMELY MODULAR SYSTEMS (EMS)

Every week brings alarming news about events such as natural disasters, humanitarian and man-made disasters, terrorist attacks, mass migration, etc. During such unexpected situations, the time is the most precious, and services provided by rapidly deployable and reconfigurable structures are invaluable. Such structures can save lives, health and improve human comfort as escape routes, infrastructure, semi-permanent refuge shelters, habitats. Moreover, they can serve in extreme situations such as warfare, or extreme environments such as undersea, arctic, or outer-space robust outposts. We develop nature-inspired reconfigurable and deployable modular structures, where the basic module is optimized simultaneously with the entire EMS structure. The objectives include the development of new EMSs capable of creating free-form surfaces and solids, and development of numerical models of such hierarchical structures.

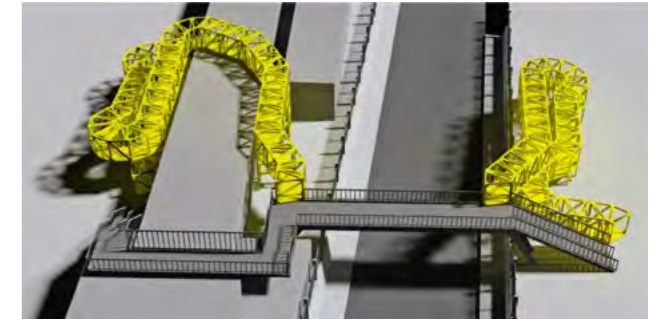


Fig. 4.4.7. Visualization of retrofitting of an existing overpass between two sections of Tokyo University Hongo Campus with an EMS (shown in yellow). Proposed gentle slope of the modular ramp allows for safe crossing of elders, small children, wheel-chair users, etc. Without the necessity of heavy equipment, EMS is a feasible solution for countless similar situations

## MOBILE ROBOTICS

Automatic navigation is of fundamental importance for all autonomous devices, ranging from robotic vacuum cleaners, through office mobile robots, up to driverless cars and unmanned aerial vehicles.

Our work is focused on data fusion algorithms of measurements from laser range finders (lidars), visual cameras (including stereo-vision), depth cameras, inertial measurement units, and GPS. The research

includes the problem of simultaneous localisation and mapping (SLAM). Particularly interesting is the problem of localisation with an insufficient GPS accuracy, i.e., in indoor or cluttered urban environment, or in extreme environments such as



Fig. 4.4.8. Aerial view of 3D map of desolated urban complex Kłomino, and a complete UAV system for aerial mapping

underwater or mines. We use advanced vision-based odometry and lidar-based methods to construct global environmental maps which can also be applied to a wide class of applications: structural monitoring, object classification, surveillance tasks, precision agriculture, and many more.



## 4.5. DEPARTMENT OF MECHANICS OF MATERIALS



**Head:**  
**Prof. Henryk Petryk**

Secretary: Agnieszka Sokalska  
room: 133  
phone: +48 22 826 98 34  
+48 22 826 12 81 ext. 255  
e-mail: alyszk@ippt.pan.pl

The department has three divisions:

- Micromechanics of Materials (Prof. Henryk Petryk)
  - Surface Layers (Assoc. Prof. Stanisław Kucharski)
  - Advanced Composite Materials (Assoc. Prof. Michał Basista)
- one research group:
- Materials Modeling (Prof. Stanisław Stupkiewicz)
- and one laboratory:
- Thermoplasticity (Michał Maj, Ph.D.)



### STAFF:

#### Professors

Prof. Henryk Petryk, Ph.D., D.Sc.  
Prof. Stanisław Stupkiewicz, Ph.D., D.Sc.

#### Associate Professors

Michał Basista, Ph.D., D.Sc.  
Katarzyna Kowalczyk-Gajewska, Ph.D., D.Sc.  
Stanisław Kucharski, Ph.D., D.Sc.  
Katarzyna Pietrzak, Ph.D., D.Sc.

#### Senior Researchers

Dariusz Jarząbek, Ph.D.  
Marcin Krajewski, Ph.D.  
Michał Kursa, Ph.D.  
Neonila Levintant-Zayonts, Ph.D.  
Maciej Ryś, M.Sc.  
Przemysław Sadowski, Ph.D.  
Agnieszka Witecka, Ph.D.

#### Ph.D. Students

Maciej Lewandowski, M.Sc.  
Michał Majewski, M.Sc.  
Sandra Musiał, M.Sc.  
Michał Wichrowski, M.Sc.

#### Technical staff

Kamil Bochenek, M.Sc.  
Urszula Czubačka  
Karol Frydrych, Ph.D.  
Paweł Hołobut, Ph.D.  
Jakub Lengiewicz, Ph.D.  
Justyna Maj, M.Sc.  
Michał Maj, Ph.D.  
Marcin Nowak, Ph.D.  
Zuzanna Poniżnik, Ph.D.  
Grzegorz Starzyński, Ph.D.  
Leszek Urbański  
Witold Węglewski, Ph.D.  
Stefania Woźniacka

#### Retired

Prof. Zenon Mróz, Ph.D., D.Sc.  
Prof. Wiera Oliferuk, Ph.D., D.Sc.

**The Department of Mechanics of Materials (DMM)** conducts comprehensive research – experimental, theoretical and computational – on advanced materials such as:

- Multifunctional and multicomponent materials (shape memory alloys, metal-ceramic composites, intermetallics, cellular materials, etc.);
- Materials of fine microstructure (nanocomposites, ultrafine-grained materials made by severe plastic deformation, etc.);
- Thin layers and coatings (ion implanted materials, plastically deformed and contact layers, interfaces, etc.).

Particular emphasis is put on:

- Micromechanical and multiscale modelling,
- Experimental studies from macro- to nano-scales.

Selected topics are described on the next pages.

### PROCESSING, CHARACTERISATION AND MODELLING OF METAL-CERAMIC COMPOSITES

The ongoing research activities comprise: processing, characterisation and modelling of metal-matrix composites (e.g. Cr/Re/Al<sub>2</sub>O<sub>3</sub>, NiAl/Al<sub>2</sub>O<sub>3</sub>, NiAl/Re/Al<sub>2</sub>O<sub>3</sub>) and functionally graded composites (Al/Al<sub>2</sub>O<sub>3</sub>) for automotive and aerospace application; nanocomposite materials based on C, Fe and Co for energy storage; and coatings on Mg-alloy substrates for biomedical applications. Macro- and micromechanical testing of fracture parameters and measurement of residual stresses by neutron diffraction, XRD and Raman spectroscopy are the main areas of advanced material characterisation. The manufacturing methods comprise powder metallurgy (hot pressing, spark plasma sintering), pressure-assisted metal infiltration of ceramic preforms and chemical reactions in magnetic field. The modelling work focuses on micro-CT based FEM simulations of thermal residual stresses and of deformation and fracture mechanisms at the microscale (Fig. 4.5.1).

### MICROMECHANICAL MODELLING OF COMPOSITE MATERIALS

Micromechanics provides a link between the microstructure and its evolution, microscopic interaction mechanisms and macroscopic properties of heterogeneous materials. Hence, it is a perfect tool to be used in the material-by-design strategies. The development of enhanced micromechanical modelling strategies is an active area of research at DMM. Recent activities include a study of the effects of particle packing and size on the overall elastic properties of the particulate composite. The two effects are accounted for by the two parameters entering the formulation: the mean minimum distance between particles and the thickness of the interphase zone. Predictions of an extended mean-field model and of computational homogenization are compared in Fig. 4.5.2. The former approach properly captures the qualitative features predicted by the latter, computationally-demanding approach.

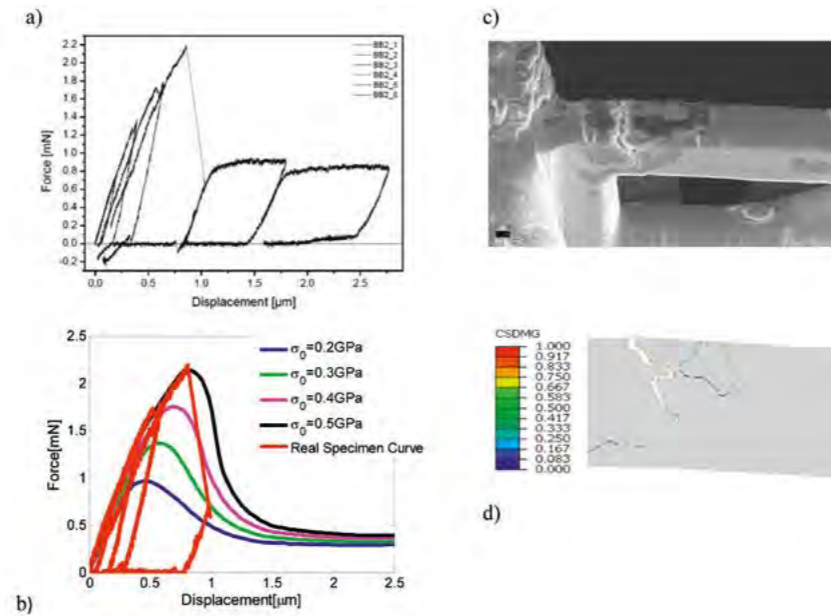


Fig. 4.5.1. Deformation and fracture of Cr/Al<sub>2</sub>O<sub>3</sub> microcantilevers in bending: experiment (top) and modelling (bottom). Tests performed at Montanuniversität Leoben, Austria

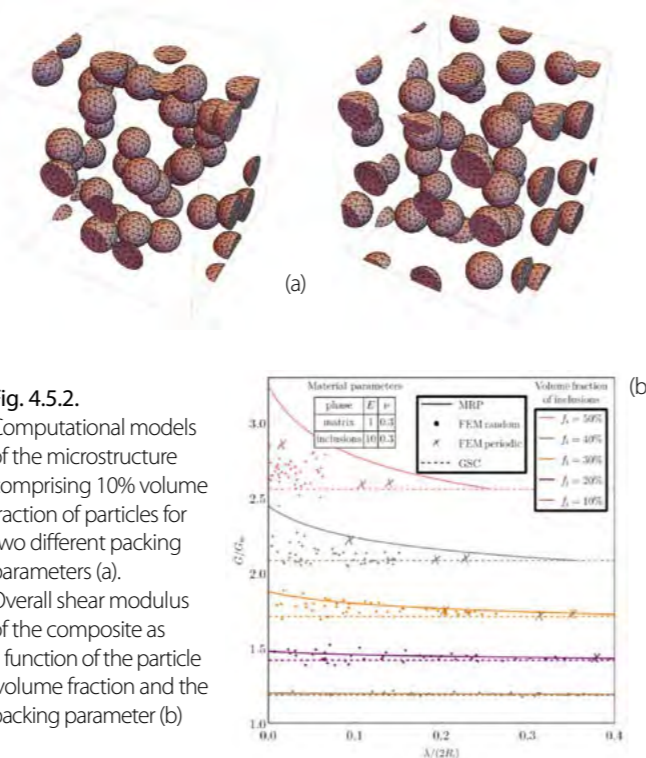


Fig. 4.5.2. Computational models of the microstructure comprising 10% volume fraction of particles for two different packing parameters (a). Overall shear modulus of the composite as a function of the particle volume fraction and the packing parameter (b)

### MICROMECHANICAL MODELLING OF (POLY) CRYSTALLINE METALS AT LARGE PLASTIC DEFORMATION

A new three-scale model of polycrystalline plasticity accounting for grain refinement has been developed. The model is based on the experimental observations showing that plastic deformation is usually accompanied by the formation of dislocation substructures in the form of dislocation cells. It has been thus assumed that a single crystallite is initially divided into subdomains that are slightly misoriented with respect to one another. Subsequently, micromechanical scale-transition schemes have been applied to describe the evolution of misorientation of subdomains, and the misorientation angle is used as an indicator of grain refinement. Satisfactory agreement between model predictions and experimental data has been obtained (Fig. 4.5.3).

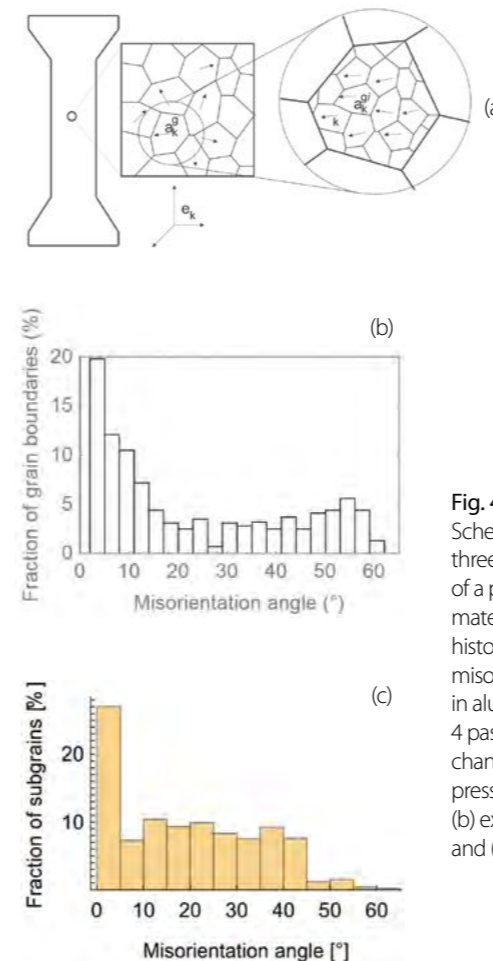


Fig. 4.5.3. Schematic of the three scale model of a polycrystalline material (a) and histograms of the misorientation angles in aluminum after 4 passes by equal channel angular pressing (ECAP): (b) experiment and (c) modelling

### INVESTIGATION OF SIZE EFFECTS BY MEANS OF MICRO- AND NANO-INDENTATION TESTS

The indentation test is commonly used to identify material properties, such as the elastic modulus, hardness, or work-hardening curve. The test can be performed on various scales and it also enables one to study the size effects. The indentation size effect has been investigated on single-crystal copper using the micro- and nano-indentation test with spherical tips of various radii R. Load-penetration depth curves have been measured as well as the topography of the residual impressions. As the tip radius decreases, the size effect manifests itself in three aspects: the normalized stiffness of the load penetration curve increases (Fig. 4.5.4), the normalized pile-up height decreases, and the shape of the contact boundary becomes closer to the circular one (Fig.4.5.5).

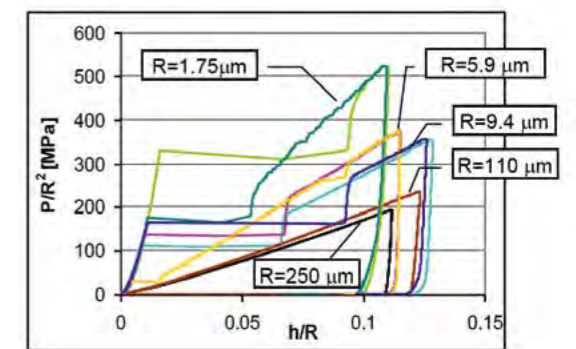


Fig. 4.5.4. Size effects in micro- and nano-indentation of a Cu single crystal: increase of the stiffness of the load-penetration curve with decreasing tip radius

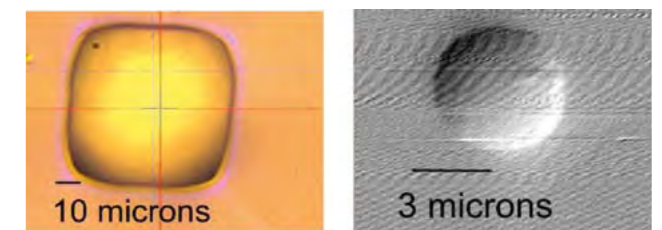


Fig. 4.5.5. Different material response in micro- and nano scale: the residual impressions after spherical indentation have clearly a size-dependent shape

**MODELLING OF SIZE EFFECTS IN CRYSTAL PLASTICITY AND PHASE TRANSFORMATIONS**

The indentation size effect (described above) has also been studied theoretically. The classical model of crystal plasticity has been extended to account for the effects of plastic slip-rate gradients and so-called geometrically necessary dislocations (GNDs). The new model has been applied to simulate spherical indentation of sin-

gle-crystal copper, achieving excellent agreement with the experiment (Fig. 4.5.6), despite the fact that the model does not have any adjustable parameter. Size effects associated with the formation and evolution of martensitic microstructures have been modelled using a recently developed finite-strain phase-field model. Predictions of phase-field modelling have been compared to our earlier sharp-interface models, and a good agreement has been obtained (Fig.4.5.7).

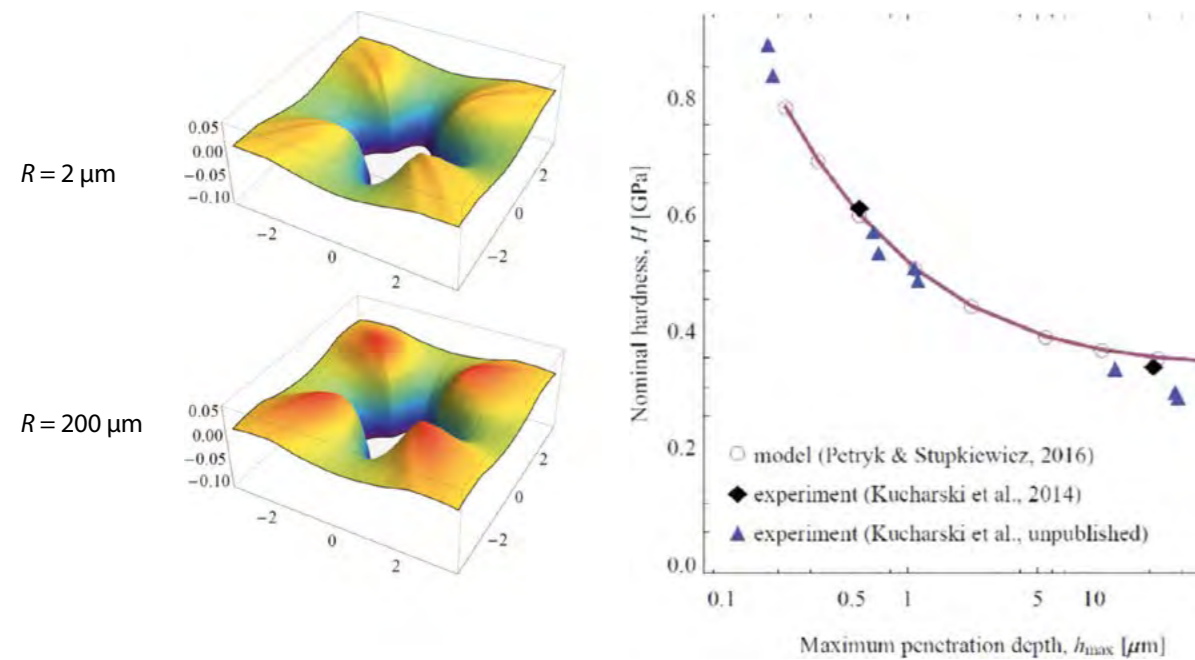


Fig. 4.5.6. Finite-element modelling of the indentation size effect: (a) size-dependent residual impressions, (b) dependence of hardness on the maximum penetration depth

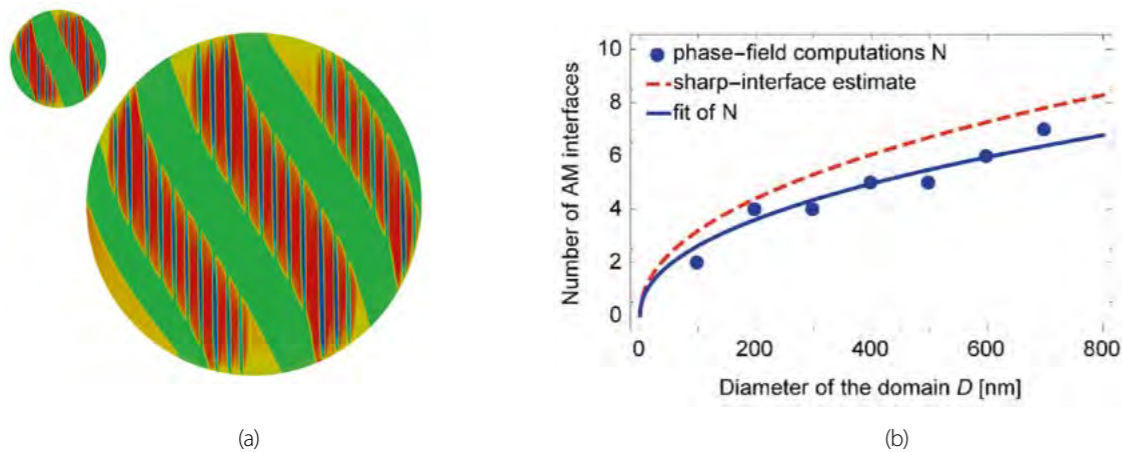


Fig. 4.5.7. Phase-field modelling of size effects in martensitic microstructures: (a) size-dependent microstructure of austenite (green) and twinned martensite (blue and red) formed within a circular grain of the radius of 200 nm (left) and 700 nm (right), (b) plate spacing as a function of grain diameter

**EXPERIMENTAL ANALYSIS OF COUPLED MECHANICAL AND THERMAL FIELDS AT THE MICRO-SCALE**

The macro-scale behaviour of a material during the deformation process is a result of structural changes at the level of its microstructure. Current research is focused on the experimental analysis of coupled mechanical and thermal fields during the deformation of crystalline materials with regard to their microstructure. A special technique has been developed in which the displacement and temperature fields are simultaneously determined

using non-contact optical methods, i.e. digital image correlation (DIC) and infrared thermography (IRT). By adequate postprocessing of those fields, one can compute the fields of strain, material rotation and the dissipated energy that is converted to heat. Examples are shown in Figs. 4.5.8 and 4.5.9. One of the main tasks of this research is to determine the relationship between the dissipated energy and the crystallographic orientation of the deformed material. Additional valuable information, such as the plastic spin at the grain scale, can be obtained by combining the proposed approach with the EBSD measurements of crystal lattice orientation.

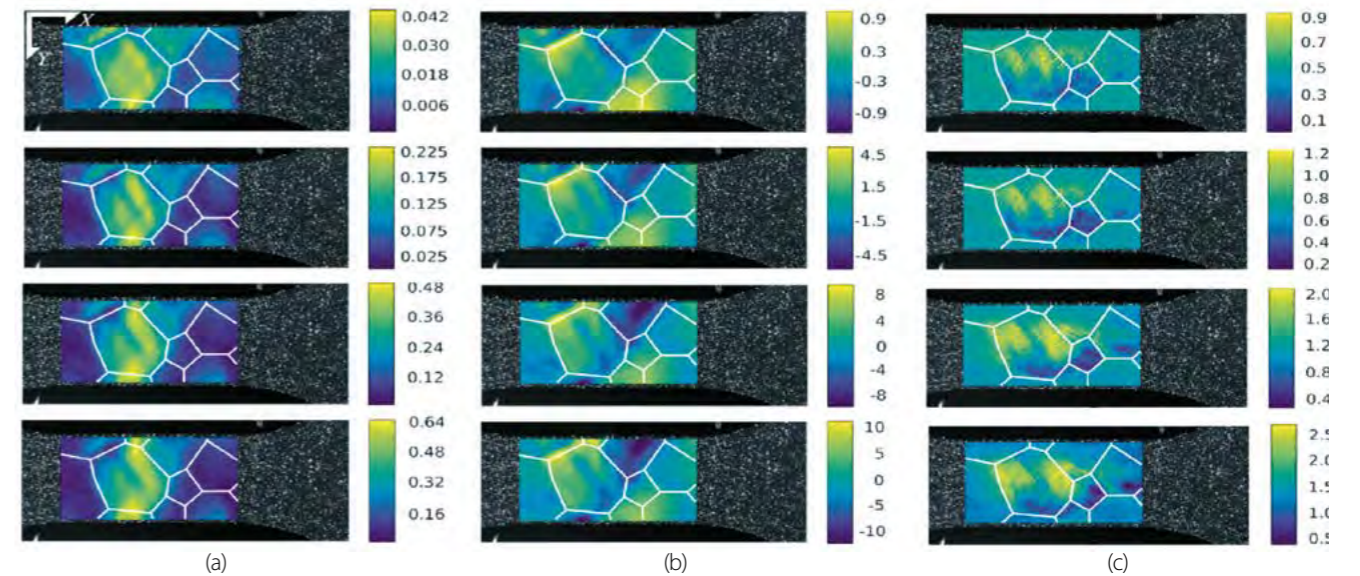


Fig. 4.5.8. Evolution of (a) strain, (b) material rotation and (c) temperature distributions during plastic deformation of Al multicrystal. Subsequent rows (starting from the top) correspond to the increasing strain. The grain boundaries are marked

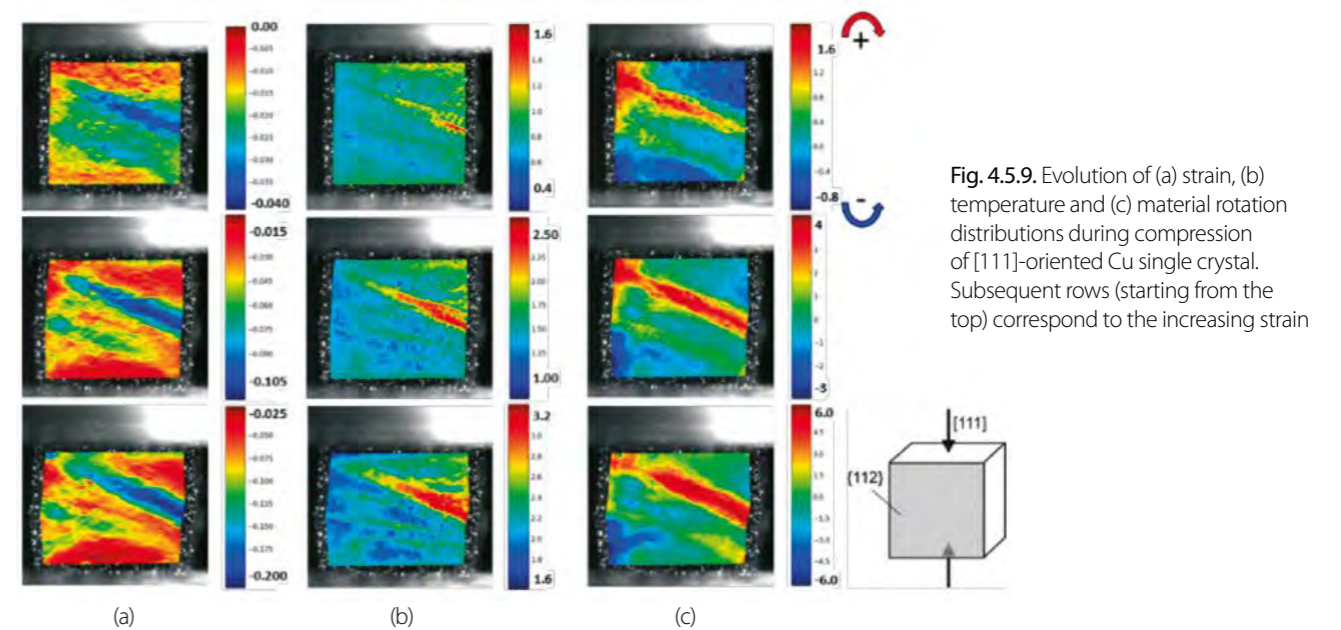


Fig. 4.5.9. Evolution of (a) strain, (b) temperature and (c) material rotation distributions during compression of [111]-oriented Cu single crystal. Subsequent rows (starting from the top) correspond to the increasing strain

**CHARACTERIZATION OF ADHESIVE LAYER  
IN METAL-MATRIX COMPOSITE**

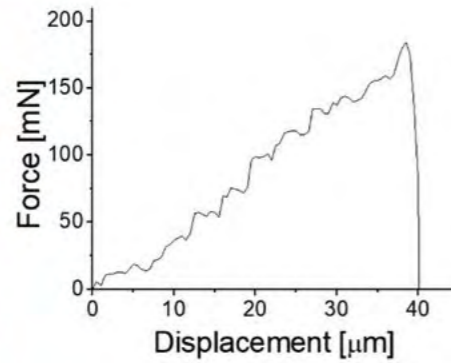
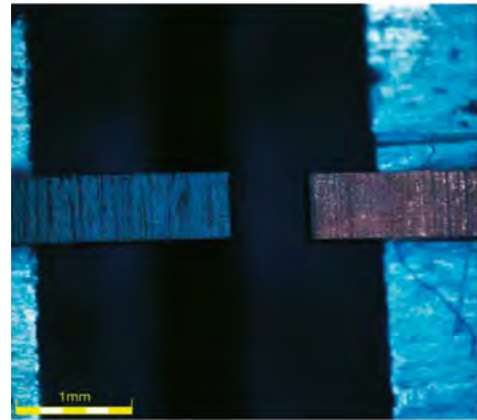


Fig. 4.5.10. Debonded ceramic and copper part of the bar after the tension test (left) and the measured load-displacement curve (right)

The adhesion force and fracture strength of the interface between ceramic particles and metal matrix in ceramic-reinforced metal matrix composites have been investigated with the use of a newly developed microtensile tester (Fig. 4.5.10).

The micro-bars that contain a single ceramic particle have been cut from a sintered Cu-SiC composite using a precision wire saw. The metal-ceramic interface has then been examined using SEM. It has been observed that the presence of metallic coatings (e.g. Cr, Ti) on the surface of ceramic particles before sintering can change the properties of the metal-ceramic interface.

**GENERATION OF THIN SURFACE LAYERS  
BY MEANS OF ION BEAM TECHNIQUES**

Thin surface layers (<600nm) that are fatigue- and corrosion-resistant are produced using ion implantation technology. The new challenge is a bio-medical application of layers implanted on Ti and NiTi alloys used in manufacturing of stents or bone implants. The corrosion resistance is analyzed by means of Solartron 1287/1260 experimental setup and mechanical properties are investigated using nano-indentation test (Fig. 4.5.11). The experiments allow one to find optimal parameters of the implantation process.

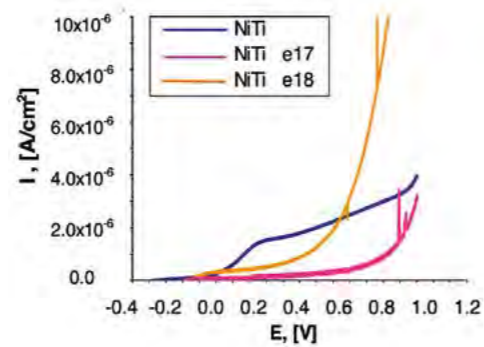
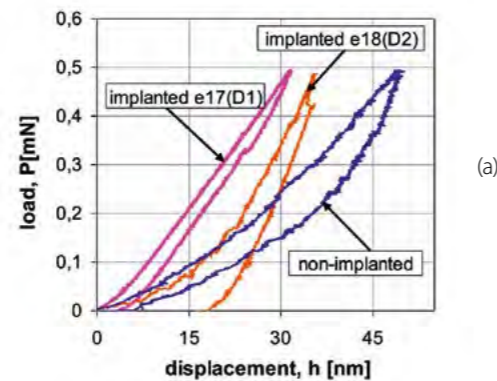
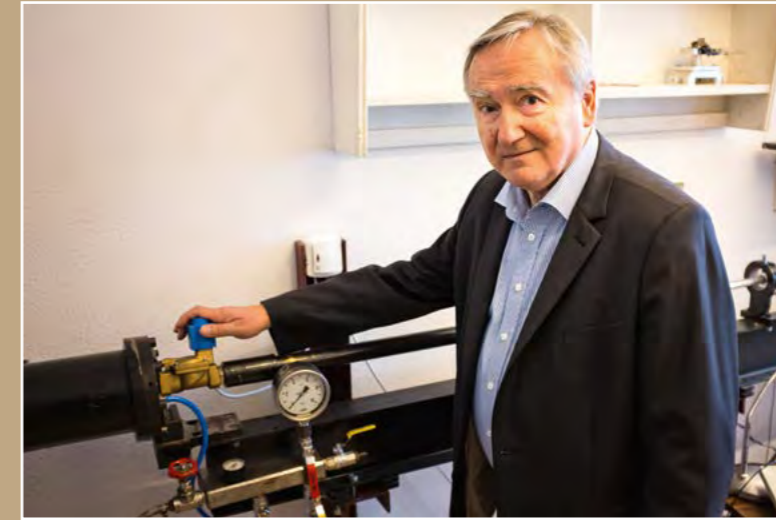


Fig. 4.5.11. Effect of ion implantation on functional properties of NiTi alloy implanted with different ion doses: (a) impact on the pseudo-elastic effect; (b) impact on the corrosion resistance

**4.6. DEPARTMENT OF THEORY OF CONTINUOUS  
MEDIA AND NANOSTRUCTURES**



Head:  
Prof. Ryszard Pęcherski

Secretary: Monika Węglowska  
room: 238  
phone: +48 22 826 98 41  
+48 22 826 12 81 ext.219  
e-mail: mweglow@ippt.pan.pl

The department has two divisions:

- Analytical Mechanics and Field Theory (Wasył Kowalczyk, Ph.D., D.Sc.)
- Polymer Physics (Prof. Ryszard Pęcherski)

and two research groups:

- Nanophotonics (Prof. Wojciech Nasalski)
- Acoustoelectronics (Assoc. Prof. Piotr Kielczyński)



## STAFF:

### Professors

Prof. Leszek Jarecki, Ph.D., D.Sc.  
Prof. Wojciech Nasalski, Ph.D., D.Sc.  
Prof. Ryszard Pęcherski, Ph.D., D.Sc.

### Associate Professors

Zbigniew Banach, Ph.D., D.Sc.  
Piotr Kielczyński, Ph.D., D.Sc.

### Senior Researchers

Amrita Jain, Ph.D.  
Wasył Kowalczyk, Ph.D., D.Sc.  
Wiesław Larecki, Ph.D., D.Sc.  
Beata Misztal-Faraj, Ph.D., D.Sc.  
Zdzisław Nowak, Ph.D., D.Sc.  
Agata Roszkiewicz-Walczuk, Ph.D.

### Ph.D. Students

Naira Grigoryan, M.Sc.

**The Department of Theory of Continuous Media and Nanostructures**, headed until March 2017 by Prof. Leszek Jarecki, investigates mechanical systems and fields with large symmetry groups and topological methods in the physics of continua, linear and non-linear theories of low- and high- molecular materials, as well as photonic and acoustic structural effects with the application of advanced continuous media methods. Some original and innovative solutions are described below.

### CLASSICAL AND QUANTUM MECHANICS OF MEDIA WITH MICRO- AND NANOSTRUCTURES

The research mainly focuses on constructing mathematical models describing mechanical properties of discrete and continuous elastic media with structures (e.g. molecular crystals, leading in the continuous limit to micromorphic or micropolar media, or liquid crystals in LCD screens). The theory of such media is based on the concept of affinely-rigid (homogeneously deformable) bodies developed by Prof. Jan J. Sławianowski and his research group. This approach is based on the geometrical and group-theoretical analysis of internal and collective

### Technical staff

Andrzej Balcerzak, Ph.D.  
Marek Dawidziuk  
Wojciech Dera, M.Sc.  
Cezary Dziekoński  
Leszek Frąś, M.Sc.  
Barbara Gołubowska, Ph.D.  
Agnieszka Martens, Ph.D.  
Ewa Rożko, Ph.D.  
Krzysztof Wieja, M.Sc.

### Retired

Prof. Jan Sławianowski, Ph.D., D.Sc.

degrees of freedom in mechanics and field theory, and the investigation of systems with large symmetry groups and their connection to essential, non-perturbative nonlinearities. One of the interesting and inspiring examples of investigated problems is connected with the classical and quantum descriptions of the motion of infinitesimal gyroscopes and infinitesimal affinely-rigid bodies in non-Euclidean spaces, particularly two-dimensional ones such as sphere, pseudo-sphere, torus or Mylar balloon. It turned out that many interesting dynamical models, including quite realistic ones, may be effectively investigated analytically. In geophysics, this can correspond to the motion of continental plates or icebergs that have

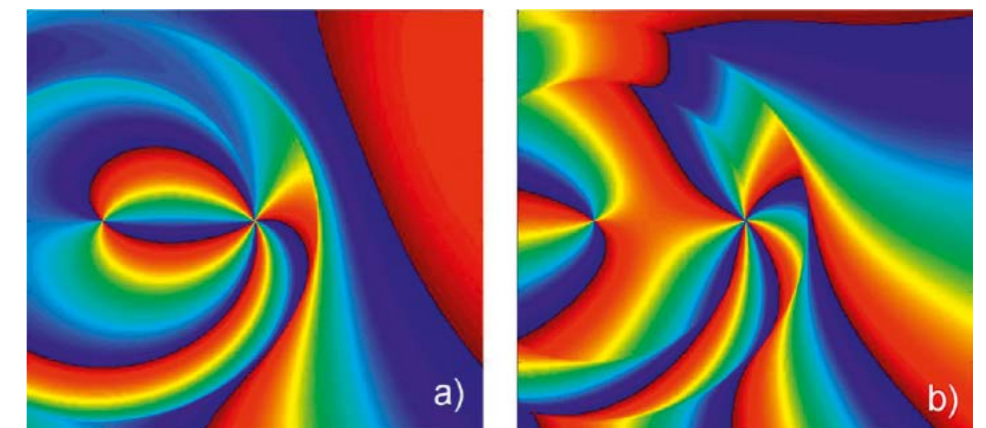
broken off a glacier or an ice shelf, floating freely in open water, or the motion of pollution, such as oil spots, on the oceanic surface.

### HEAT TRANSPORT AND RADIATION HYDRODYNAMICS DEDICATED TO MICRO- AND NANOSTRUCTURES

The heat transport in non-metallic micro- and nanostructures is described in terms of a phonon gas flow. There is evidence that the nonlinearity of a phonon dispersion relation strongly influences the thermal properties of micro- and nanostructures, and that the heat transport is of wave-type at low and at elevated temperatures. Therefore, the two-moment phonon gas hydrodynamics which takes into account the nonlinearity of the phonon dispersion relation has been derived in a general form. For the derivation, it is assumed that the system of governing equations of conservative form is hyperbolic and consistent with the balance of entropy. Then, the propagation of thermal waves of weak discontinuity is studied. It shows that the calculated wave speeds are in agreement with experimental data for Ge and Bi crystals. The evolution equations governing a phonon gas flow and the equations of radiation hydrodynamics exhibit similarities, since they both originate from the general kinetic theory of massless quantum gases. Within the framework of moment methods of this kinetic theory, the two-field radiation hydrodynamics in  $n$ -spatial dimensions has been derived in the full-moment (frequency independent) and in the spectral (frequency dependent) formulations.

### BEAM AND PLANE WAVE ANALYSES OF OPTICAL FIELD PHOTONIC INTERACTIONS WITH PLANAR MULTILAYERS AND PERIODIC NANOSTRUCTURES

In many photonic applications of optical beams, their transverse cross-section should be narrow, with a diameter, in the beam waist, of the order of one wavelength. Within this range, paraxial approximation of beam-fields is not sufficient and standard corrections by field expansions with respect to small parameters are not efficient, either. Thus, there is a need for more accurate beam-field description. An exact vector solution to free-space propagation is given in terms of elegant or complex-valued Laguerre-Gaussian  $eLG_{p,l}$  beams with their radial  $p$  and azimuthal  $l$  indices. The analysis starts from the known paraxial field approximation. Next, through bidirectional field transformation and application of vector potentials, the analysis leads, without any approximation, to an exact, closed form, beam-field vector solution. The novelty of the results obtained stems from the complete redefinition of nonparaxial corrections to the paraxial solution to the problem. The method works well not only for the free-space propagation, but also in the description of optical beam interactions with planar interfaces and multilayers. One numerical result, shown in **Fig. 4.6.1**, has been obtained by the Fourier modal analysis of such interaction under the  $eLG_{2,4}$  critical incidence, which leads to the cross-polarised excitation and splitting of the reflected and transmitted beams.



**Fig. 4.6.1.** Vortex excitation and splitting at a dielectric interface for critical incidence of elegant Laguerre- Gaussian  $eLG_{2,4}$  beams of left-handed and right-handed circular polarisation. That yields phase splitting of  $eLG_{3,2}$  (a) and  $eLG_{1,6}$  (b) reflected beams of opposite circular polarisation

Analyses are also carried out on plane wave interactions with a silver finite two-dimensional stripe photonic crystal. The crystal is composed of horizontally one-dimensional periodic sets of dielectric stripes forming a periodic sequence of layers in the orthogonal to the horizontal plane direction. The stripes in all layers are arranged in parallel and the horizontal metal gratings are buried in a dielectric host material. Optical characteristics of such a photonic crystal are numerically analysed with the use of the multilayer Rigorous Coupled Wave Analysis.

The analysis shows qualitative changes in the optical response of the crystal originated from modifications of the thickness  $d$  and the filling factor  $f$  of each layer and the polarisation direction of the incident wave.

The crystal manifests its various characteristics in the wideband or narrowband reflection and transmission, while field absorption remains low. Behaviour of the crystal is determined by its structure geometry yielding excitation of localised plasmons and collective modes together with interactions between them. The optical response of this square lattice structure is also compared with the response of a triangular lattice crystal. One numerical example of such interaction for different values of the structure parameters  $d$ ,  $f$  and the field wavelength is presented in Fig. 4.6.2.

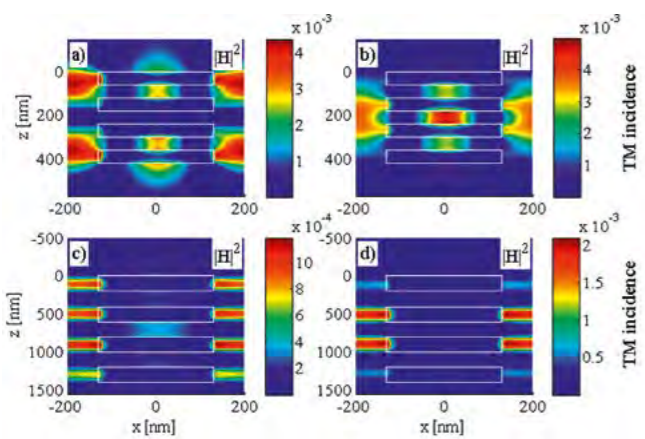


Fig. 4.6.2. Magnetic field distributions for the configuration with  $f=0.65$  and incidence of TM polarisation: a)  $d=60$  nm,  $\lambda=471$  nm, b)  $d=60$  nm,  $\lambda=530$  nm, c)  $d=200$  nm,  $\lambda=675$  nm, d)  $d=200$  nm,  $\lambda=738$  nm

### KINETIC MODEL OF NONISOTHERMAL CRYSTAL NUCLEATION WITH TRANSIENT AND ATHERMAL EFFECTS

The elaborated model is based on kinetic equation of the development of cluster size distribution. Closed-form analytical formula for the distribution development in the single-relaxation-time approximation is derived, as well as, thermal and athermal nucleation rates and total number of nuclei produced in the cooling or heating runs. It is shown that the transient term contributes to isothermal nucleation kinetics with increase of temperature. Under non-isothermal conditions, the relaxation time contributes to the nucleation kinetics by the product with the cooling/heating rate. Considerable transient effects are predicted for the relaxation times as long as 102-105 s. The contribution of thermal nucleation to the total concentration of nuclei is inversely proportional to the temperature rate, while the contribution of athermal nucleation depends on the temperature interval of cooling or heating. The kinetic model indicates similarities in the nucleation mechanisms in polymers and metals undergoing crystallisation. Fig. 4.6.3. illustrates an example of crystal nucleation in a linear polymer – polyhydroxybutyrate where a low temperature limit is predicted for thermal nucleation mechanism, while for metals, the mechanism is active in the entire temperature range.

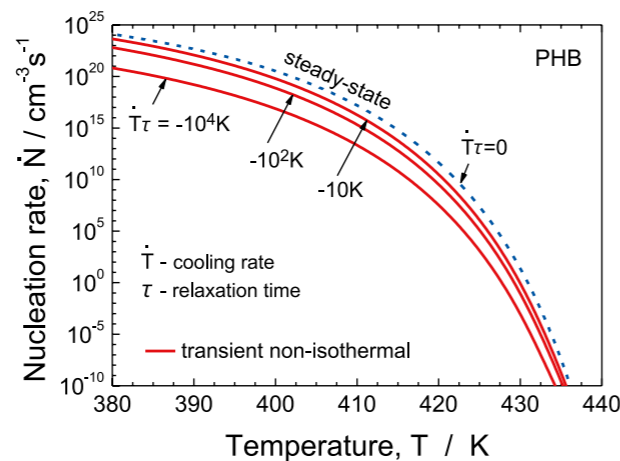


Fig. 4.6.3. Thermal nucleation rate with the transient effects vs temperature for crystallization of polymer polyhydroxybutyrate (PHB) with various products of the cooling rate and the relaxation time,  $\dot{T}\tau$

### NONLINEAR STRESS-ORIENTATION BEHAVIOUR OF FLEXIBLE CHAIN POLYMERS UNDER FAST ELONGATIONAL FLOW

Tensile force and orientation characteristics are considered for single, flexible chain macromolecule and for systems of chains in real polymer melt subjected to uniaxial elongational flow. A closed-form analytical formula is derived for an intermediate tensile stresses in the first non-Gaussian term approximation and the high-stress nonlinearity formula is derived with the inverse Langevin nonlinear chain statistics under high rate elongational flow. Both formulas are validated by exact numerical calculations. Ranges of applicability of the formulas are illustrated in Fig. 4.6.4.

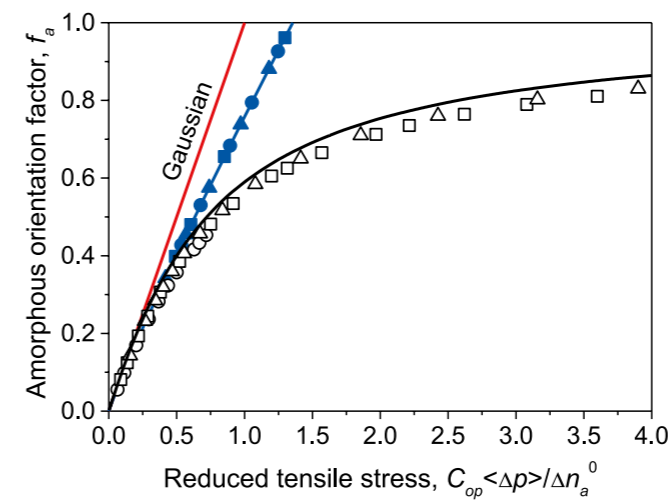


Fig. 4.6.4. Amorphous orientation factor  $f_a$  vs. reduced tensile stress  $C_{op} \langle \Delta p \rangle / \Delta n_a^0$ . Thick solid line: nonlinear analytical formula; lines: first non-Gaussian term approximation; Gaussian approximation. Open points – the results computed for various elongation rates

### BREAKING NANOCRYSTALLINE SILICON PILLARS - INNOVATIVE CALIBRATION PROCEDURE

The novel study focuses on the observation of nanopillars of various diameter below 200 nm made of deposited nanocrystalline silicon, which can be used in Micro and Nano-Electromechanical Systems. The nanopillars are subjected to shear under atomic force microscope in lateral-force microscopy mode. The innovative direct calibration method has been developed. The method uses a micro-force sensor for direct measurement of the friction force applied by the cantilevers tip to a flat silicon surface. Due to the third law of dynamics, the friction force of the equal value tilts the cantilever. Therefore, torsional (lateral) signal is compared with the signal from micro-force sensor and the lateral force calibration constant is calculated, the error of the method is below 3%.

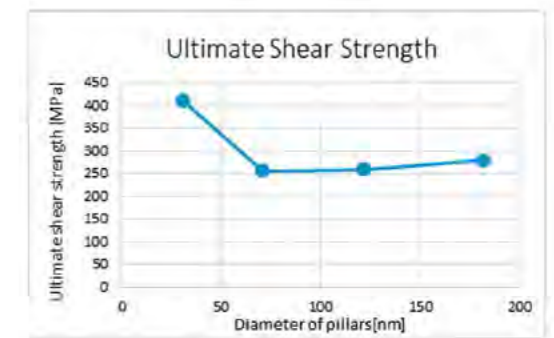
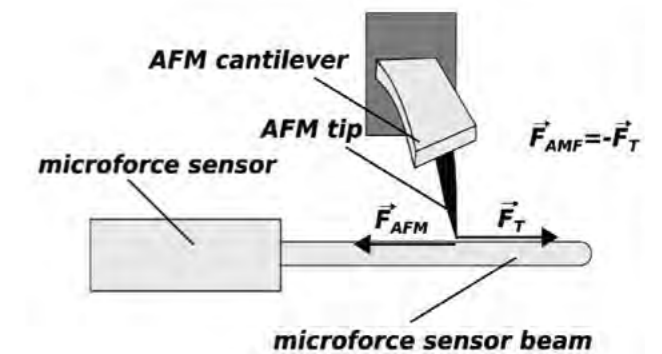


Fig. 4.6.5. Scheme of the innovative calibration procedure and the ultimate shear strength of pillars

**INNOVATIVE ULTRASONIC SENSORS  
TO STUDY HIGH-PRESSURE PHASE  
TRANSITIONS IN BIOFUELS**

The high-pressure phase transitions occurring in bio-fuels is the subject of research in the Group of Acoustoelectronics. The discovery of high pressure phase transition was possible due to the employment of novel sensors based on Love and Bleustein-Gulyaev surface waves theory developed in the Group. Recent achievements are marked by the discovery of new basic properties of Love surface waves and the development of a new method to characterise viscoelastic parameters of materials from measurements of the dispersion curves (phase velocity and attenuation) of Love surface waves propagating in solid waveguides. The inverse problem methods in conjunction with optimisation techniques were developed and applied to the high-pressure phase transitions studies.

Blue color – low-pressure phase  
Black color – phase transition  
Red color – high-pressure phase

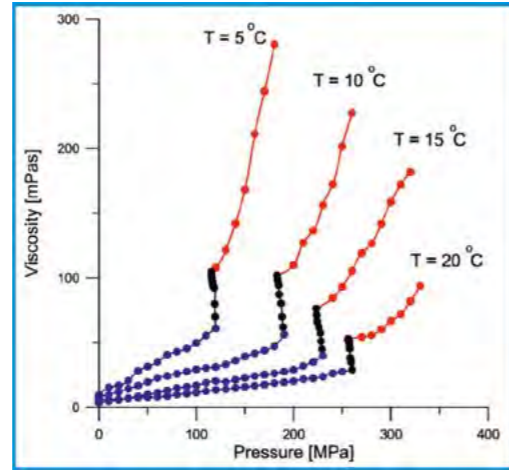


Fig. 4.6.6. Attenuation of Love surface waves, propagating in PMMA-Quartz waveguides, as a function of the PMMA surface layer thickness  $h$ , for different frequencies of the surface wave

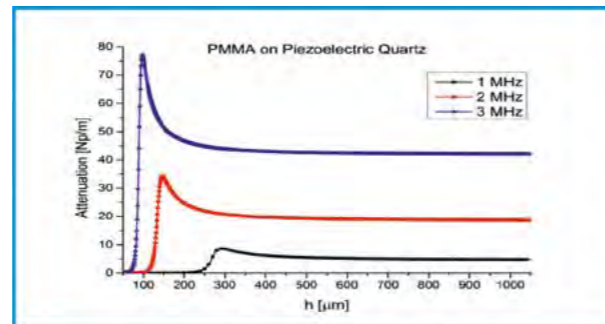
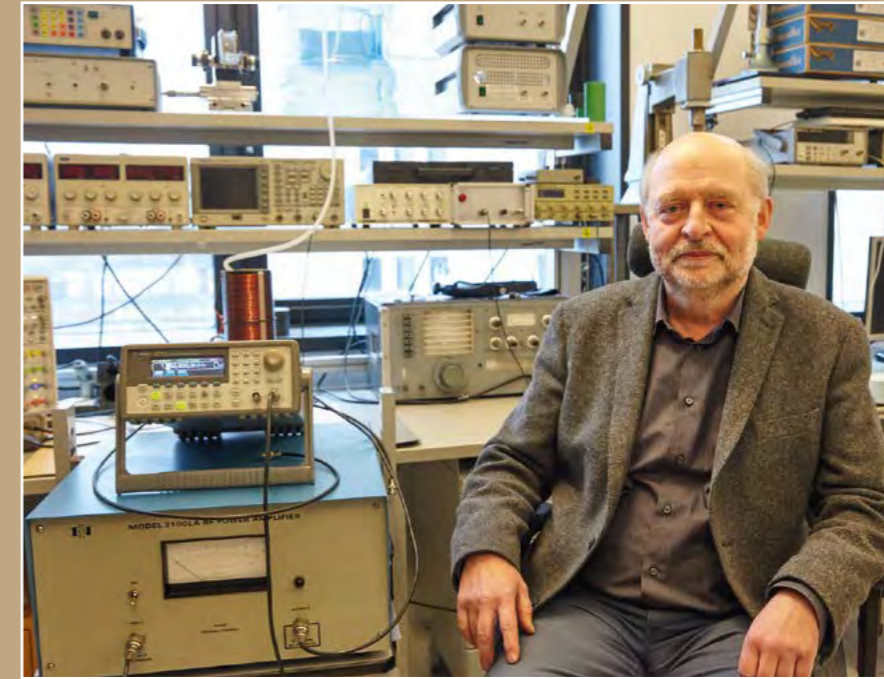


Fig. 4.6.7. Viscosity of the rapeseed methyl esters (RME) sample measured as a function of pressure  $p$  for different temperatures ( $T = 5\text{ }^{\circ}\text{C}$ ;  $10\text{ }^{\circ}\text{C}$ ;  $15\text{ }^{\circ}\text{C}$  and  $20\text{ }^{\circ}\text{C}$ )

**4.7. DEPARTMENT  
OF ULTRASOUND**

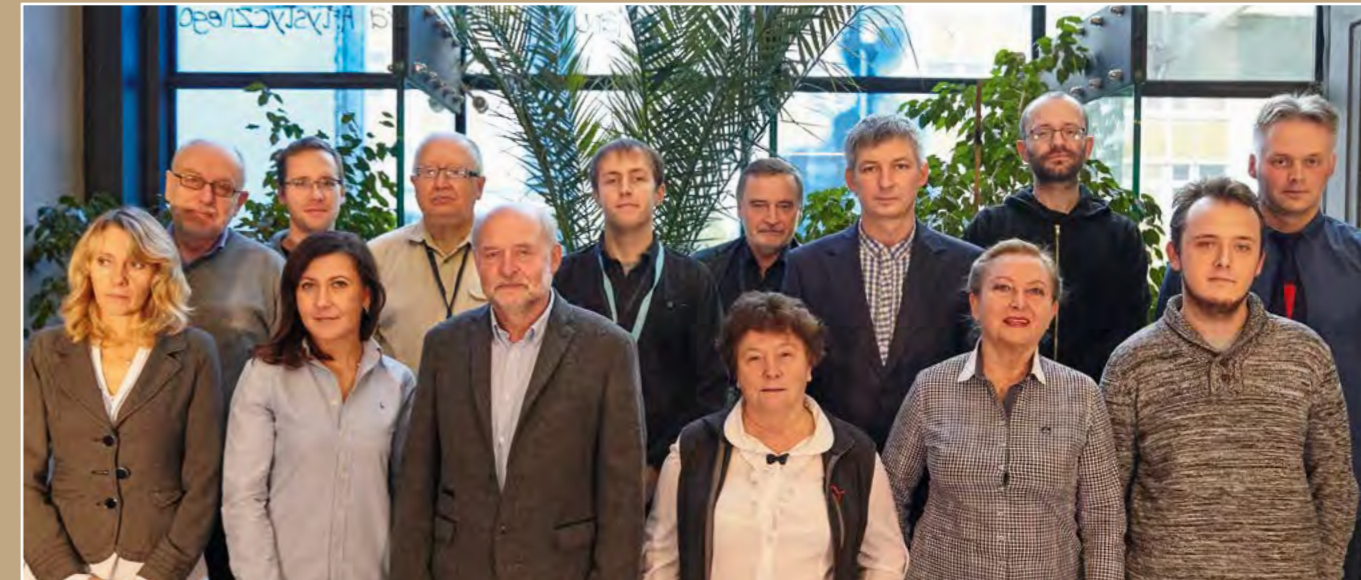


Head:  
Prof. Jerzy Litniewski

Secretary: Monika Węglowska  
phone: +48 22 826 98 41  
+48 22 826 12 81 ext.219  
e-mail: mweglow@ippt.pan.pl

The department has three divisions:

- Ultrasonic Introscopy (Assoc. Prof. Janusz Wójcik)
- Acoustic Microscopy (Prof. Jerzy Litniewski)
- Biomechanics (Assoc. Prof. Barbara Gambin)



## STAFF:

### Professors

Prof. Andrzej Nowicki, Ph.D., D.Sc.

### Associate Professors

Barbara Gambin, Ph.D., D.Sc.

Tamara Kujawska, Ph.D., D.Sc.

Prof. Jerzy Litniewski, Ph.D., D.Sc.

Janusz Wójcik, Ph.D., D.Sc.

### Senior Researchers

Michał Byra, Ph.D.

Ziemowit Klimonda, Ph.D.

Hanna Piotrkowska-Wróblewska, Ph.D.

Jurij Tasinkiewicz, Ph.D., D.Sc.

### Ph.D. Students

Łukasz Fura, M.Sc.

Ilona Korczak, M.Sc.

### Technical staff

Katarzyna Dobruch-Sobczak, M.D. Ph.D.

Piotr Karwat, Ph.D.

Eleonora Kruglenko, Ph.D.

Robert Olszewski, Ph.D., D.Sc.

Wojciech Secomski, Ph.D.

Ryszard Strzałkowski

Zbigniew Trawiński, Ph.D.

Ihor Trots, Ph.D.

Ryszard Tymkiewicz

Norbert Żołek, Ph.D.

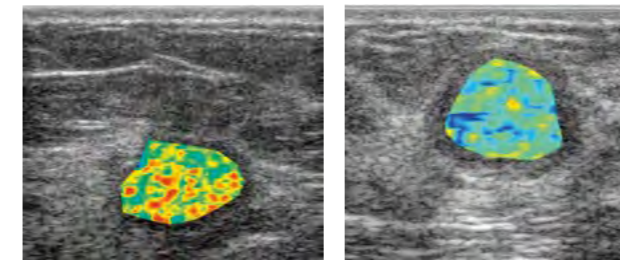
For many years, the **Department of Ultrasound** has been conducting research to improve quality of methods supporting diagnostics and medical therapy. It is still one of the main topics being developed in the Department. In three laboratories, the research is conducted on ultrasound characteristics of tissues, thermal phenomena induced by ultrasound absorption, the modelling of ultrasound propagation in biological media, forming of the acoustic fields generated by multi-element transducers and methods of ultrasonic image reconstruction.

## QUANTITATIVE ULTRASOUND OF BREAST TISSUE – APPLICATION TO LESIONS CLASSIFICATION AND PREDICTION OF CANCER RESPONSE TO CHEMOTHERAPY

Ultrasonography (USG) is one of the basic medical examinations conducted for the purpose of breast disease diagnosis. Quantitative ultrasound (QU) imaging with RF signal analysis provides additional information on morphological features of breast tumors.

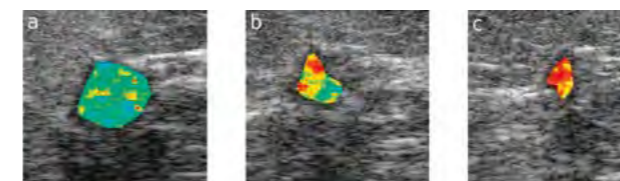
The assessment of tumor malignancy degree is an important issue because an accurate diagnosis of breast

tumors plays an important role in therapy planning, positively affects the patient's prognosis and can improve the overall chance of survival. In turn, preoperative (neoadjuvant) chemotherapy is used in patients with clinically advanced breast cancer to improve the effectiveness of surgical treatment and to lower the risk of cancer recurrence. It also contributes to the increase in numbers of the breast-conserving procedures and reduces the mortality rate of patients. Monitoring the effectiveness of treatment in such patient groups is particularly important in order to individualise treatment and reduce its toxicity.

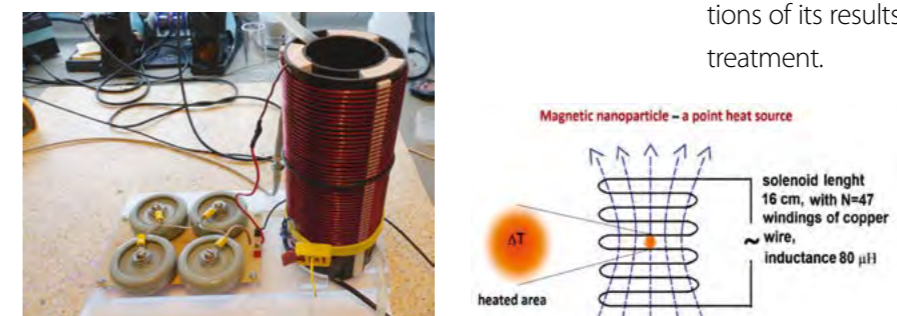


**Fig. 4.7.1.** QU images (distribution of weighted entropy) of the two types of breast lesions, malignant - cribriform breast carcinoma (left) and benign - breast adenocarcinoma (right). The red and blue colors correspond to high and low entropy values respectively

In cooperation with the Maria Skłodowska-Curie Memorial Cancer Centre, Institute of Oncology in Warsaw, we focused on the research of ultrasonic biomarkers of tumor changes and tumor response to chemotherapy. The physical parameters of the tumor tissue, texture parameters of tumor images and statistical parameters of ultrasonic backscatter were derived from ultrasonic echoes. Those parameters that best reflected changes in tissue were presented in the form of QU maps. Results demonstrated that QU imaging can differentiate between malignant and benign breast lesions and non-invasively monitor the response of the breast cancer patients to chemotherapy, following the treatment initiation.



**Fig. 4.7.2.** Patient with complete remission. QU imaging maps based on homodyned K distribution present a decrease in shape parameter for tumor treated with chemotherapy (from blue to red). Prior to treatment (a), after the third medicine dose (b) and after the NAC course (c)



**Fig. 4.7.3.** The system consists of a coil, Generator Agilent Technologies 33250A, Amplifier ENI.INC Model 3100LA RF and water circulation cooling system used to obtain the thermally insulated space inside the coil in which homogeneous magnetic field appears

## HEATING BY MAGNETIC AND ULTRASONIC FIELDS OF SAMPLES DOPED WITH IRON OXIDE NANOPARTICLES

Magnetic nanoparticles (MNP) are now widely used in medicine, both in therapies and in diagnostics. Here, our main area of interest is the application of magnetic nanoparticles as thermal agents in the localised magnetic and ultrasonic hyperthermia due to hyperthermic effect observed when nanoparticles are exposed to the alternating magnetic field or to the ultrasound field. Magnetic hyperthermia uses the magnetisation reversal losses of MNP in an alternating magnetic field whereas ultrasonic hyperthermia uses the effect of sound absorption to achieve local heating of the tissue to treat tumors. The main goal of our research is to find links between thermal effects of ultrasonic and magnetic hyperthermia. The ultrasonic and magnetic absorption rates, being the measures of hyperthermia efficiency, are obtained from experimentally measured rate of temperature variations at the starting time point of heating.

The study of hyperthermia by simultaneous application of both, magnetic and ultrasound fields, needs dedicated equipment. To measure the magnetic hyperthermia by controlled alternating magnetic field, the dedicated system, was constructed (**Fig. 4.7.3**). With the help of the system, the first performed experiments confirmed the possibility of measuring the temperature increase, 8-10°C, in the magnetic fluid located inside the coil during 5 minutes of application of an alternating magnetic field.

Further studies of the simultaneous use of magnetic and ultrasonic fields to improve hyperthermia performance are challenging both for basic research and the applications of its results in innovative hyperthermia for cancer treatment.



### NOVEL METHOD FOR IMPROVEMENT OF QUALITY OF ULTRASOUND ECHOES VISUALISATION

The purpose of the study is to develop methods with low computational complexity, improving the quality of ultrasound signals obtained from periodic transceivers. Such transceivers are commonly used in ultrasonic scanners and generate the noise by the grating lobes. The foundations of the phenomenon of this structural noise is described by the diffraction grating theory. Without reduction, the noise from grating lobes occupies significant imaging areas and change the image of an object or hides the details of its structure below the noise level — red rectangles (Fig. 4.7.4.).

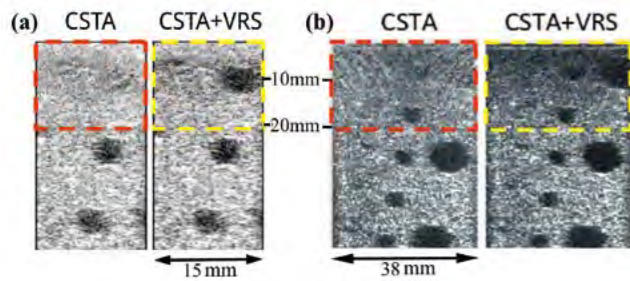


Fig. 4.7.4. Images of tissue-mimicking phantom obtained using an transceiver array of various sizes: (a) - 64 elements, (b) - 128 elements; Effect of grating lobes noise on imaging quality — red rectangles and the result of Virtual Receiving Subaperture application — yellow rectangles

A new method of Virtual Receiving Subaperture for the suppression of the influence of grating lobes noise has been developed. It consists of generating virtual signals, non-existing physically, in real transceivers. Virtual Receiving Subaperture method is a kind of a spatial filter that effectively increases the density of detectors. During reconstruction, the Virtual Receiving Subaperture also creates a grating lobes signal, however, with a phase opposite to that generated by the real aperture. As a consequence, both signals perform self cancellation. The use of Virtual Receiving Subaperture is highly noise-suppressing and thus enable early detection and improvement of the diagnosis of tissue with emerging pathology or material structure. Objects previously barely visible or invisible become visible — yellow rectangle in Fig.(a,b)

### DESTRUCTION OF SOLID TUMORS BY MEANS OF PULSED FOCUSED ULTRASONIC BEAMS

In recent years, new therapeutic approaches have been proposed for the treatment of solid cancers by means of focused ultrasound (FUS). The technology utilizing pulsed focused ultrasound waves is a non-invasive technique to destroy primary solid tumors or their metastases localized deep beneath the skin. Therefore, it produces significantly less complications and side effects than conventional treatments (surgery, radio- and/or chemotherapy).

Therapy using FUS beams with low local intensity (in the focal area) rely on tumor hyperthermia (40-43°C). During the process, thermo-sensitive liposomes filled with a cytotoxic drug are selectively delivered to the tumor and release the drug locally due to their cracking induced by ultrasonic waves. The therapy which uses FUS with high local intensity relies on the thermo-ablative destruction of the tumor volume without damaging the surrounding healthy tissues.

The research objectives were to design an automated device dedicated to small animal studies and capable of simultaneous:

- guiding the focus of the heating beam on the interior of an implanted tumor;
- heating a small volume inside the tumor to a suitable temperature;
- automatic spatial scanning of the entire tumor volume by the heating beam focus;

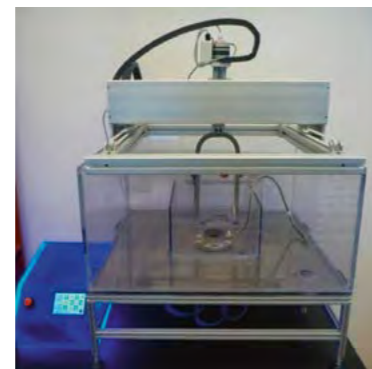


Fig. 4.7.5. Automated bimodal ultrasonic device designed for thermal destruction of solid tumors in preclinical studies

### ESTIMATION AND MEASUREMENT OF THE STREAMING VELOCITY

The aim of the project was to use the streaming phenomena to assist clots dissolution in blood vessels. Such treatment is called sonothrombolysis. Acoustic streaming is a steady flow in a fluid driven by the acoustic wave propagating in a lossy medium. The streaming depends on the intensity and absorption of ultrasound in the media. For high frequencies exceeding 20 MHz the speed of streaming in blood is also affected by scattering effects on the blood cells and the contrast agent microbubbles. We have modified the theoretical description of streaming by adding the scattering coefficient to equations describing the radiation force and the streaming velocity.

Theoretical calculations confirmed the increase in streaming velocity for the blood-mimicking starch concentration, very similar to the experimental results. The theory has also shown the ability to reduce the streaming velocity by low-density scatterers. It was experimentally proved using BR14 ultrasonic contrast agent.

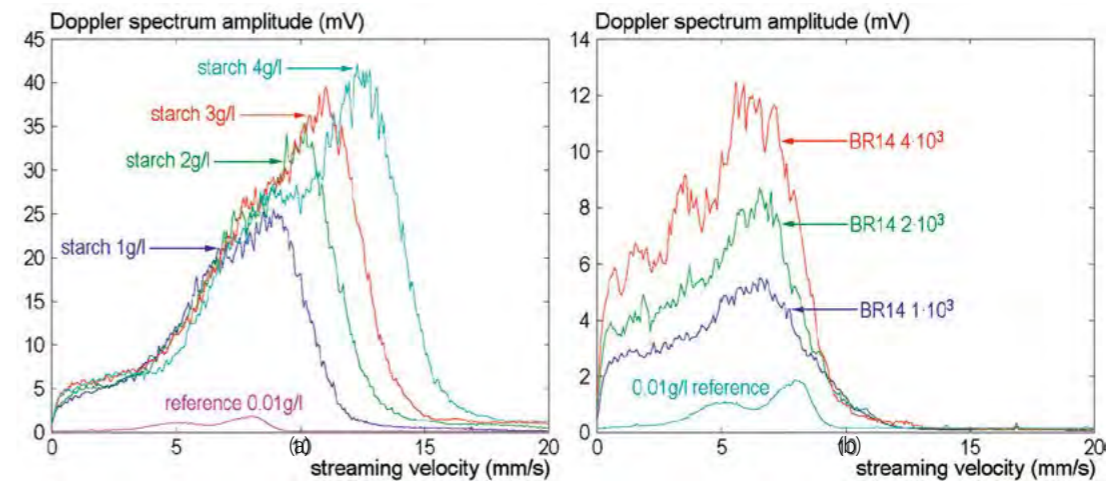


Fig. 4.7.6. Doppler velocity spectrum of the signal scattered on blood-mimicking starch in concentrations of 0.01 and 1 - 4 g/l (a), and scattered on BR14 contrast in concentration of 1 - 4·10<sup>3</sup> microbubbles /mm<sup>3</sup> (b)

## 4.8. LABORATORY OF POLYMERS AND BIOMATERIALS



**Head:**  
**Prof. Paweł Ł. Sajkiewicz**

Secretary: Agnieszka Ponarska  
room: 329  
phone: +48 22 826 98 03  
+48 22 826 12 81 ext. 228  
e-mail: aponar@ippt.pan.pl



### STAFF:

#### Professors

Prof. Paweł Ł. Sajkiewicz, Ph.D., D.Sc.

#### Senior Researchers

Arkadiusz Gradys, Ph.D.

Dorota Kołbuk-Konieczny, Ph.D.

Tomasz Kowalczyk, Ph.D.

#### Technical staff

Piotr Denis, M.Sc.

Judyta Dulnik, M.Sc.

Olga Urbanek-Świderska, M.Sc.

#### Ph.D. Students

Olga Cegielska, M.Sc.

Katarzyna Czarnecka, M.Sc.

Oliwia Jeznach, M.Sc.

Beata Niemczyk, M.Sc.

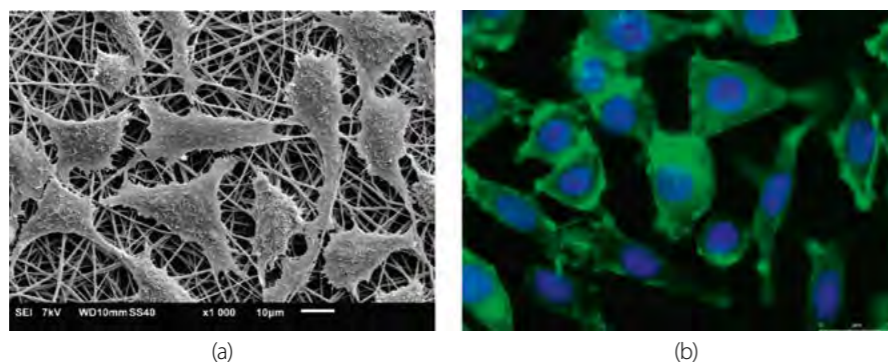
Taking into account the evolving challenges of the modern world, our recent activity is mainly focused on the area of biomedical applications of polymeric materials. One of the important scientific topics researched by the Laboratory of Polymers and Biomaterials in 2016-2017 concerned the fast growing area of tissue engineering and regenerative medicine. Tissue engineering is a relatively new, interdisciplinary branch of science and technology, which combines biology, biotechnology, chemistry, and materials science, aiming to repair or replace portions of or even whole tissues (i.e. bone, cartilage, blood vessels, skin etc.). Our research concentrates on the part of tissue engineering related to biodegradable polymers used as scaffolds for cells/tissues as well as to materials for drug release. Our activity can be divided into three main groups:

- investigations on the effect of electrospinning parameters on a structure and properties of polymeric nano- and submicron fibres; this area has a rather fundamental character, but also a considerable potential of application in tissue engineering;
- optimisation of the scaffold formed by various methods for regeneration of bladder, urinary tract and ligaments /tendons, nerves etc.; this activity has strong applicability;
- investigations of the kinetics of polymer crystallization under various conditions, such as non-isothermal regime or under spatial confinements; this area of research is related to fundamental problems.

1) Electrospinning process is one of the most prospective methods of scaffolds formation. It allows formation of submicron- and nanofibres, mimicking the natural structure of extracellular matrix (ECM). Our main aim is to optimise the process of scaffolds formation and resulting structures of electrospun fibres from the perspective of their applications for the regeneration of various tissues.

The investigated polymers are biocompatible and biodegradable, with time of biodegradation being dependent on a particular application. In our research, we use both synthetic polymers and biopolymers such as collagen, gelatin and chitosan. One of the important polymer systems being investigated by our group is the blend of polycaprolactone (PCL) and gelatin. PCL has good mechanical properties and is non-cytotoxic. In comparison to other materials from

the group of aliphatic polyesters, it has higher deformability and its degradation products do not cause a decrease in pH in the area surrounding a graft. However, as any other aliphatic polyester, PCL is hydrophobic, which is the disadvantage for a material used as scaffolds. In our laboratory, this problem is solved by the addition of gelatin, which is a hydrolyzed form of collagen, the major ECM building protein. Gelatin not only increases the hydrophilicity of the material, but also contains arginyl-glycyl-aspartic acid (RGD) amino acid sequences which are an effective mediator for cell attachment, recognized by the integrins, a family of cell-surface proteins. This way, the biopolymer addition promotes cell attachment and spreading to the surface of a material. Electrospinning of bicomponent nanofibres such as PCL/gelatin requires solvents which dissolve both of the polymers. To date, the most common compounds used in such systems have been perfluorinated alcohols such as 1,1,1,3,3,3-hexafluoro-2-propanol (HFIP) and 2,2,2-trifluoroethanol (TFE). These solvents are expensive and they are also classified as highly toxic. So far, we have optimised the process of electrospinning of PCL/gelatin and PCL/collagen nanofibres based on the use of non-toxic, alternative solvents - acetic acid and formic acid. The application of the mixture of these acids reduces manufacturing costs and is much less hazardous for operators of the electrospinning process. As a consequence of solvent change, there are some implications for nanofibres structure and resulting cells activity. Two of our recent projects deal with certain aspects of this relationship, with emphasis on the analysis of fibroblast activity in vitro conditions (Fig. 4.8.1).



**Fig. 4.8.1.** Images of mouse L929 fibroblast cells cultured for 5 days on nanofibrous scaffolds of polycaprolactone with gelatin electrospun using alternative solvent system a) scanning electron microscope; b) fluorescent microscope

We are, in general, interested in investigating the effect of electrospinning conditions on morphology/structure of resulting fibres, having the optimisation of scaffolds for tissue engineering in perspective. The determination of the general "formation conditions - structure - properties" relationship for a particular material system enables further optimisation of electrospinning from the perspective of cellular response. This type of analysis we apply for

various biodegradable polymers, suitable for various types of tissues with specific requirements. One of the examples of this research is the project related to the effects of electrospinning with polarity change on resultant nanofibre structure and properties. Such tailoring of electrospun nanofibre surface functionality in a one-step manufacturing process within an electrospinning line is expected to be a generic method for exploitation where nanofibre surfaces define application. At the moment, such electrospinning using positive and negative polarity applied voltages is being used to produce PCL /chitosan nanofibres.

Another area of our research, which is still rather basic but have strong application potential, is related to drugs delivery systems made from nano- and sub-micron fibres. The aim of this study is to investigate the influence of polymer matrix structure and spatial distribution of biologically active substances produced in plant tissues on the kinetics of their release. The most recent thread of our

activity is related to injectable hydrogels for regenerative medicine, particularly for the regeneration of central nervous system (CNS). The chemical composition of such materials should be carefully tailored in order to obtain crosslinking at the body temperature. Several compositions, based mostly on polysaccharides, are currently under research to meet the requirements set before clinical applications.

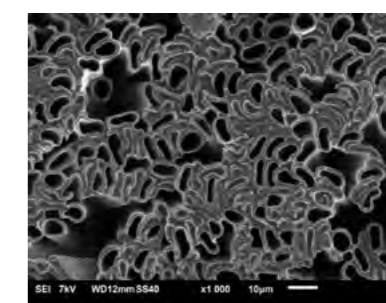
2) In the area of most applicable activity, it is well worth mentioning our efforts towards the formation of some medical products from biodegradable polymers, for instance wound healing materials, tendon and ligament prostheses as well as expandable biodegradable external support device mitigating causative factors for early and late graft failure.

In cooperation with the Nicolaus Copernicus University Collegium Medicum in Bydgoszcz, a scaffold material for bladder and urinary tract regeneration was optimised, which is now being subjected to preclinical studies on rats. Research on the formation of external stent for venous graft using biodegradable polymers, produced by electrospinning, is in close collaboration with the Military Institute of Medicine in Warsaw. The goal is to develop an effective external stent for coronary artery bypass surgery in the treatment of coronary heart disease. The use of biodegradable materials will eliminate the negative effects of the distant reaction of the body to foreign bodies such as commonly used nitinol. In a number of studies, biodegradable materials have proved to be effective in improving venous drainage. Together with the Laboratory of Semipermeable Membranes and Bioreactors of the Institute of Biocybernetics and Biomedical Engineering, Polish Academy of Sciences, we are currently working on developing a hybrid material for cartilage regeneration that results in patent application.

Another important project, with similar application perspective, involves creating a bioactive, hybrid graft for the regeneration of anterior cruciate ligaments (ACL). The solutions proposed in the project will serve as an

alternative for current treatments of knee injuries, which are not as effective as expected. The project focuses on the development of a biodegradable scaffold for the regeneration of knee ligament. By utilizing knowledge in the fields of natural sciences, mechanics, biology and medicine, the hybrid biodegradable product will be optimised. Graft prototype is under development and is moving towards the final stage. The in-vivo studies are planned in the near future.

3) The last but not least part of our research concerns investigations of phase transitions in polymers. We investigate the kinetics of polymer crystallization under various conditions such as non-isothermal processes or under spatial confinements, for instance, in the core part of electrospun core-shell nanofibres. In the case of non-isothermal crystallization we are focused on processes occurring at ultra-fast rates of temperature changes, reaching 106K/s, similar to polymer processing conditions. In the case of crystallization occurring in the core part of core-shell nanofibres, we deal with two-dimensional geometrical confinements. In such systems, interplay of several confinement effects of various nature on both morphology and crystallization kinetics is observed (Fig. 4.8.2.). The crucial aspect is the comparison of the experimental results with various models of polymer crystallization.



**Fig. 4.8.2.** Scanning electron microscope image of cross-section of "core-shell" fibres electrospun coaxially, used for studies of phase transitions under spatial confinements

Conducting scientific research, we do not forget about the educational and popularizing activity. We conduct seminars and lectures for external scientific institutions as well as give lectures and laboratory presentations for the pupils from primary and secondary schools during annual Science Festivals.

# 4.9. JOINT LABORATORY OF MULTIFUNCTIONAL MATERIALS

## SCIENTIFIC BOARD:

### IPPT PAN

Prof. Tomasz A. Kowalewski  
Prof. Jerzy Litniewski  
Prof. Paweł Ł. Sajkiewicz

### WIM PW

Prof. Krzysztof J. Kurzydłowski  
Assoc. Prof. Wojciech Świeszkowski

Secretary: Aneta Ciesielska  
phone: +48 22 828 53 73, e-mail: aciesiel@ippt.pan.pl



Biomaterials Group, Materials Design Division,  
Faculty of Materials Science and Engineering, Warsaw University of Technology (WIM PW)

The **Biomaterials Group** is a research group focused on the investigation and development of advanced materials for medical application. The main aim of the Biomaterials Group is to develop and initiate new technological solutions for biomaterials, implants, tissue engineering products and drug delivery systems for the purpose of treatment of human diseases as well as for improving human health.

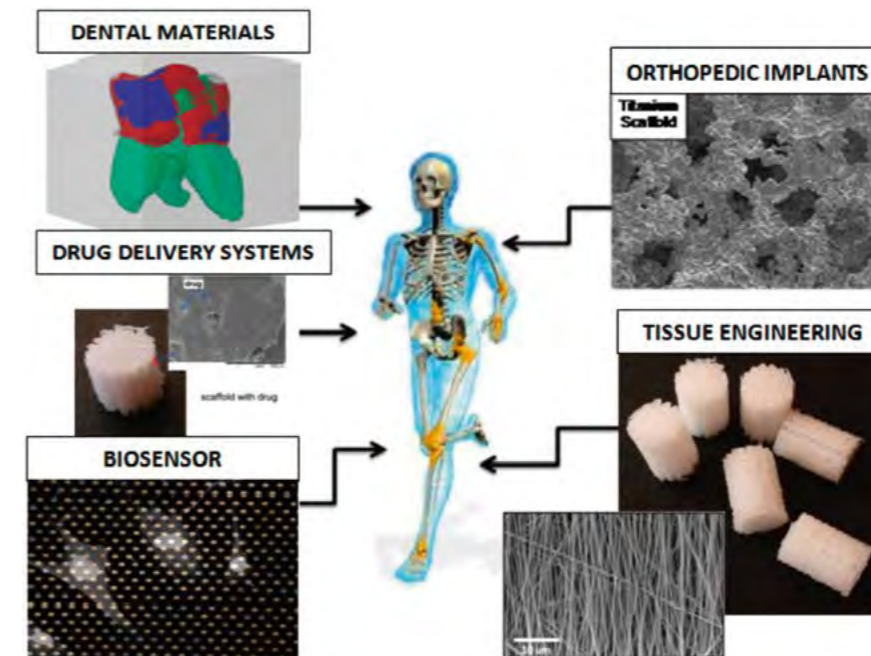


Fig. 4.9.1. Scheme of research interests of the Biomaterials Group

The Group's research is concentrated primarily on finding solutions for the cartilage and bone tissue repair and regeneration.

The Group's main areas of strength and interest are the following research topics:

- a) Biomaterials and advanced scaffolds for the repair of articular cartilage and bone defects including advances in micro and nanotechnology to design and process biomaterials (e.g., polymeric and metallic porous structures, biodegradable synthetic polymers as well as polymer-ceramic composites, nanofibers) that can guide, accelerate, and/or act as a template for tissue regeneration and/or formation;
- b) Biomaterials for artificial joints including the development of new materials for implants (artificial-cartilage hydrogels and nanotitanium, magnesium alloys), ceramic coatings (CaP and TiO<sub>2</sub>), and study

on the performance of orthopedic total joint replacement (e.g., hip, knee, elbow, and shoulder implants) through fundamental materials studies including materials testing and implant retrieval analysis;

- c) Biomaterials for dental restoration including optimisation of the composite microstructure of restorative materials in stomatology with the aim to improve mechanical properties and reduce the contraction during the polymerisation by reinforcement of the composites with nanoparticles;
- d) Drug delivery systems including the development of nanostructure polymeric systems for drug delivery;
- e) Modelling (e.g., using finite element methods) for biomaterials and implant-tissue systems including the computation of stress concentration in non-homogenous materials and biological systems, and scaffold design and optimisation.

# 5. CENTRES

## A) SCIENTIFIC CENTRES

### Centre of Excellence and Innovation of Composite Materials

**Head: Assoc. Prof. Michał Basista**

The centre gathers researchers from four research divisions of IPPT PAN: Advanced Composite Materials, Laser Technological Applications, Micromechanics of Materials, and Computational Methods in Nonlinear Mechanics, who have metal-ceramic composites in their current research agendas. The primary focus of the centre is on metal-ceramic bulk composites, functionally graded composites (FGM), and composite coatings stimulated by the needs of automotive, aerospace, energy and medical industries. In 2016-2017, the centre continued to carry out processing, characterising and modelling work on bulk composites (e.g. Cr(Re)/Al<sub>2</sub>O<sub>3</sub>, NiAl(Re)/Al<sub>2</sub>O<sub>3</sub>, AlSi12/Al<sub>2</sub>O<sub>3</sub>) manufactured by powder metallurgy and metal infiltration, and ceramic coatings (e.g. ReB<sub>2</sub>, WB<sub>4</sub>) by pulsed laser deposition. The new research fields launched at the centre include (i) composite coatings based on bioglass and chitosan deposited on Mg-alloy substrates with target applications in biodegradable implants, (ii) iron-nickel and iron-cobalt core-shell nanocomposite materials for energy storage (e.g. lithium-ion batteries) and biomedical use (e.g. magnetic hyperthermia treatment). The centre cooperates with Polish companies from the energy sector (FPM S.A., SEFAKO S.A) and with R&D partners from the European Virtual Institute on Knowledge based Multifunctional Materials.

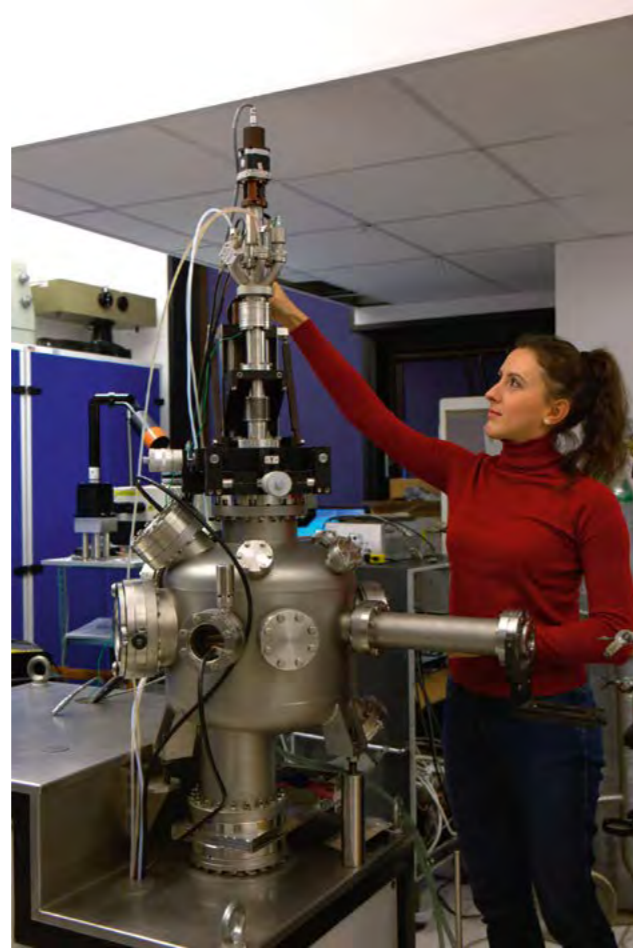


Fig. 5.1. Justyna Chrzanowska-Giżyńska, Ph.D. Student at the Laboratory of Technological Laser Application Division



Fig. 5.2. Laboratory of Advanced Composite Materials Division

More: <http://pzmk.ippt.pan.pl/CDIMK>

### Biomedical Research Centre

**Head: Prof. Tomasz Lipniacki**

The centre gathers more than 30 researchers from two departments and one independent laboratory. The investigations extend from systems and cellular biology to biomedical applications of biopolymers and ultrasound techniques, and are supported by about 20 national and EU grants.

Working on improving anti-bleeding bandage we demonstrated that, by modifying surface roughness and chemistry of nanofibers, we can influence the conformation of adsorbed fibrinogen protein leading to the activation of coagulation cascade. Combining natural and synthetic polymers in the process of electrospinning, and applying surface functionalisation, we obtained nanomaterials acting on multiple mechanisms of blood coagulation and decreased bleeding time.

We proposed new ultrasound diagnostic methods of evaluation of breast cancer response to chemoradiotherapy. We use ultrasonic biomarkers which characterise tissue structure changes resulting from therapy. The method involves creating parametric maps of cancer and monitoring the variability of the map along with the therapy used. The results allow to rapidly change the treatment in the absence of a positive tumor response, thereby reducing the treatment toxicity and improving the patient's survival.

In cooperation with the Military Institute of Medicine, we pursued the development of external stents for venous graft using biodegradable polymers. The goal is to develop an effective stent for coronary artery bypass surgery in the treatment of coronary heart disease. The use of biodegradable materials allows to eliminate negative effects of the distant reaction of the body to foreign bodies.

Fig. 5.3. Safety Engineering Laboratory in the Polish Academy of Sciences Centre for Energy Conversion and Renewable Resources

### Centre for Intelligent Technologies

**Head: Prof. Jan Holnicki-Szulc**

The centre operates in a close collaboration with the new Centre of PAS – Energy Conversion and Renewable Sources (KEZO) in Jablonna, providing advanced research infrastructure for the development of systems increasing safety in industry and transportation.

The centre carries out research on systems of adaptive impact and modelling of protective structures against high velocity impacts and blasts. The application of adaptive impact absorbers provides significant reduction of dangerous accelerations caused by dynamic loads due to semi-active or real-time changes of mechanical characteristics of a shock absorber.

The new additive technologies allow for a production of new lightweight materials without compromising their mechanical properties. The Centre for Intelligent Technologies cooperates in a research on metallic cellular materials, which are manufactured by direct selective laser melting in a powder bed fusion technology.

In the field of structural health monitoring (SHM) the research is focused on the application of FBG fiber optics sensors and development of embedded platforms for wireless distributed monitoring. Additionally, the application of the 3D aerosol jet printing technology allows for integration of sensing circuits made of functional inks into the monitored structures (e.g. glass-fiber composites).



## B) OTHER CENTRES

### Centre for Research Results Commercialization and Technology Transfer

**Head: Teresa Pawełek, M.Sc.**

The main objective of the centre is to support the scientific staff of the Institute in activities oriented at commercial applications of their research results. For the last two years, a number of agreements for the commercialization of technologies developed at the Institute have been concluded. In particular, four licenses have been granted to four companies to exclusive commercial use of know-how developed at the Institute and cooperation contracts with two companies for the development of new technologies for the aviation sector have been signed. In addition, the centre has provided recommendations in the field of cooperation with the energy and aviation sectors, as well as provided advice to the Institute's employees in the preparation of patent applications and the protection of intellectual property rights and their records. In order to disseminate good commercialization practices, the centre has organized a series of trainings for the Institute's employees on the following topics: How to translate patent to the business; Financial settlement of the projects; and Commercialization potential of massive parallel calculations in lidar data.

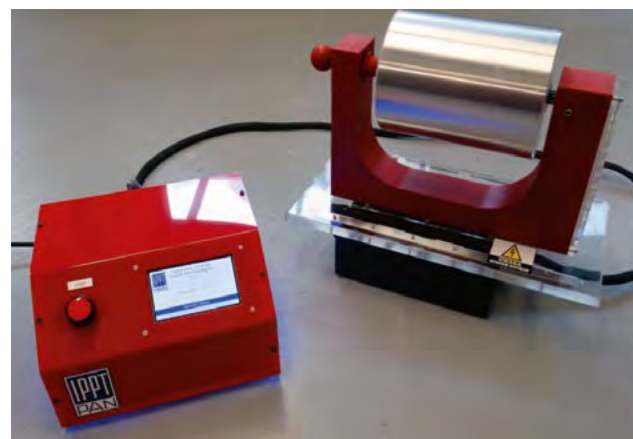


Fig. 5.4. Roller V2.0 - collector for electrospinning of nanofibers (CUL)

### Laboratory Services Centre (CUL)

**Head: Andrzej Krawczyk, M.Sc.**

Laboratory Service Centre is a technical entity established to support research projects within the framework of broadly understood activities of our Institute. The centre's state-of-the-art machinery, including high-precision CNC machine tools, wire electrical discharge (ED) machines, grinders and cutters, provides strong preparatory and manufacturing base. Furthermore, the ability of using advanced CAD/CAM software for 3D modelling as well as specialized electronic equipment facilitates the projects' visualisation and development prior to their completion.

The centre's commitment to support various researches and to participate in projects in cooperation with engineers and scientists with a lot of know-how in the fields of electrospinning, electrophoresis, ultrasound as well as material strength analysis and mechanics, ensures high quality of all provided services. In 2016 – 2017, the centre had several accomplishments, including completing several new projects, as well as designing and constructing prototypes of devices intended for use in mechanical engineering, medicine and biomaterial technology. A device called Roller, to be used in electrospinning a fiber and nanofiber production method, is an example of such accomplishments.



Fig. 5.5. Prototype of device for intraoperative stem cell delivery (CUL)

The experience of centre's staff and their continuous professional development also enabled to produce equipment necessary for conducting strength analyses of metal materials. In addition, as a result of the cooperation of IPPT PAN with the Faculty of Medicine at the University of Warmia and Mazury a prototype of a device for intraoperative stem cell delivery was designed and built with the aim to be adopted for use in operative fields.

The Laboratory Service Centre is well-equipped and prepared to produce: small series of precise and difficult-to-make components; samples made from various materials such as plastics, ultra-high strength steel, nickel composites, as well as molybdenum, titanium and aluminum alloys. The existing resources of our laboratory allow to build professional testing setups and equipment for projects carried out by other scientific research institutes, industry institutes and universities.



Fig. 5.6. Demonstration of the applicator, supervised by Prof. Wojciech Maksymowicz - Dean of the Faculty of Medical Sciences of the University of Warmia and Mazury (in the middle), at the presence of Prof. Tadeusz Burczyński, Director of IPPT PAN, Prof. Tomasz A. Kowalewski and Andrzej Krawczyk

On August 8th, 2016 the University Clinical Hospital in Olsztyn performed an opening ceremony of its Emil Behring Centre for Experimental Medicine, during which a new device for intraoperative stem cell delivery, designed and produced by the IPPT PAN, was officially handed in by the

Institute's delegation: Prof. Tadeusz Burczyński – Director of IPPT PAN; Prof. Tomasz A. Kowalewski – Deputy Head of the Department of Biosystems and Soft Matter; Andrzej Krawczyk, M.Sc. – Deputy Director for Investments and Łukasz Cichacki from the Laboratory Services Centre at IPPT PAN (CUL IPPT PAN).



Fig. 5.7. Prof. Tadeusz Burczyński gives an interview to TVP journalists in front of the University building

Present at the ceremony were the Minister of Health - Konstanty Radziwiłł and Prof. Wojciech Maksymowicz - Dean of the Faculty of Medical Sciences of the University of Warmia and Mazury in Olsztyn.

Also at the ceremony, Prof. W. Maksymowicz announced the opening of a new research programme: "Together with our colleagues at IPPT PAN, at "Repty"- the General Jerzy Ziętek Upper Silesian Rehabilitation Centre and the Neurosurgery Clinic in Dusseldorf, we want to fight for the restoration of motor skills of patients with paraplegia caused by spinal core injuries", he said.



Fig. 5.8. The device and its inventors (left to right): Łukasz Cichacki from the Laboratory Services Centre at IPPT PAN (CUL IPPT PAN) and Mirosław Chorab (CUL IPPT PAN)

## 6. NATIONAL CONTACT POINT FOR RESEARCH PROGRAMMES OF THE EU

### WE SUPPORT THE INNOVATORS OF TOMORROW !

National Contact Point for Research Programmes of the EU (NCP Poland) performs the role of the Polish NCP for the Horizon 2020 (H2020), EURATOM-Fission, Innovative Medicines Initiative 2 and coordinates the Polish part of the EURAXESS Network. We coordinate the work of the Polish NCP Network, which comprises of NCP Poland and 11 Regional Contact Points located in major academic centres in the country. NCP Poland is an integral part of the European NCP Network and is funded by the Ministry of Science and Higher Education in Poland and the European Commission.

**OUR MISSION** is to reinforce the position of Polish science and innovation on the international arena. To do this, we provide support for Polish organisations in applying for funding from research and innovation programmes of the EU. We assist Polish leaders of research and innovation: individual researchers, research organisations, entrepreneurs and any other stakeholders interested in funding of this type.

**OUR STAFF** consists of experts with unique knowledge, backed with many years of practical experience concerning the implementation of research and innovation projects funded by the EU.

**OUR OFFER** includes free-of-charge support in preparing project proposals, providing trainings, consultations, mentoring, partner search services, hosting information days and brokerage events, as well as conferences.



Fig. 6.1-2. Horizon 2020 Space Information Day and Brokerage Event in Warsaw, 2017, organized by COSMOS 2020 – the Network of Horizon 2020 SPACE NCP, NCP in Poland with support of the European Commission, photo: S. Duszyńska/NCP

Webpages: [www.kpk.gov.pl](http://www.kpk.gov.pl), [www.euraxess.pl](http://www.euraxess.pl), [www.en.kpk.gov.pl](http://www.en.kpk.gov.pl). Social media: Facebook KPK.Polska, Twitter @KPK\_PL  
Contact information: phone: +48 22 828 74 83, e-mail: [kpk@kpk.gov.pl](mailto:kpk@kpk.gov.pl)

### ACTIVITIES OF THE NCP POLAND DURING 2016 AND 2017

Providing one-stop shop services, we focus on client's needs, quality of services and put great emphasis on the identification of parties with the potential for applying for H2020 funding and on support in the process of proposals preparation. In the period 2016-2017, we managed to reach every scientific organisation

with B category in Poland. Our services have been evaluated at 4,6 (on a 5-point scale). Our activities are performed in close cooperation with the Ministry of Science and Higher Education in Poland and other ministries, executive agencies and institutions that shape the R&I sector in Poland as well as Permanent Representation of the Republic of Poland to the EU and PoISCA Office in Brussels, the European Commission and European Parliament.

### IN THE PERIOD OF 2016-2017 THE MAIN ACTIVITIES OF NCP POLAND INCLUDED:

- I. **29000 individual consultations** (personal/phone/e-mail), incl. pre-screening of proposals and 103 dedicated mentoring activities preparing institutions for proposal submissions in different areas of H2020.
- II. **Organisation/co-organisation of important events:**
  - 1) 48 information days (2170 participants)
  - 2) 88 trainings/workshops (1780 participants) on financial and legal aspects and preparation of proposals
  - 3) 41 international brokerage events, including 2 events in Warsaw:
    - Polish-British Circular Economy Brokerage Event, December 7, 2017
    - H2020 Space International InfoDay and Brokerage Event, December 13-14, 2017
  - 4) Conferences and expert meetings, including
    - "National Event of Poland: The Synergies with Research and Innovation Funds: Stairway to Excellence" Conference, Warsaw, April 27, 2016
    - "Horizon 2020 - where we are and where we are going to - opportunities and challenges for Poland" Conference, Warsaw, June 3, 2016
    - "Building a national innovation ecosystem based on the model of KIC / EIT - synergy of structural / national funds" Conference, Warsaw, September 27, 2016
    - Digital Innovation Hubs in Horizon 2020, Warsaw, March 7, 2017
    - "How to effectively create research and development strategies in the Polish industry?" Conference, Warsaw, May 17, 2017
    - "Telemedicine and eHealth" Conference, Warsaw, September 8, 2017
    - "The round table for industry", Warsaw, September 21, 2017
    - Technological visit to KGHM Polska Miedź SA and the conference on cooperation within Horizon 2020, Lubin, September 29, 2017
    - European Research Council PI Centric Event, Warsaw, October 23, 2017
    - Mobility and Career Days and a seminar for Polish awardees of HR logo (Warsaw, Krakow, Poznań, Gliwice, Łódź), October 2017
    - H2020 communication campaign on financial and legal issues, Warsaw, November 28, 2017.



**Fig. 6.3. (left)** Study visit on Bioeconomy, Brussels. Organised in cooperation between the Polish NCP for Research Programmes, Polish Embassy in Brussels and Permanent Representation of Poland to the EU in Brussels, photo: S. Duszyńska/NCP



**Fig. 6.4. (right)** „Breakfast for Polish industry” meeting in the Centre of Creativity in Warsaw, photo: S. Duszyńska/NCP

### III. Organization of 4 Study visits to Brussels (170 participants)

- Sustainable Process Industry, November 9-10, 2016
- Big Data for Transformation of the Industry 4.0, March 21-22, 2017
- Polish excellence for sustainable development of Bioeconomy in Europe, October 17-18, 2017
- COST towards Framework Programmes - 4<sup>th</sup> Meeting of the Polish NCP Network, November 21-22, 2017.

**IV. Initiating “Polish Universities - Strategy for Horizon 2020”** campaign combined with new remuneration rules campaign, in cooperation with Regional Contact Points and Conference of Rectors of Academic Schools in Poland (Warsaw, Poznań, Kraków), November-December 2017

### V. Promotion and communication activities:

- running Polish Horizon 2020 portal ([www.kpk.gov.pl](http://www.kpk.gov.pl)) and English-language Horizon 2020 portal ([www.en.kpk.gov.pl](http://www.en.kpk.gov.pl)) as well as EURAXESS Poland portal ([www.euraxess.pl](http://www.euraxess.pl))
- organizing the Gala of the Crystal Brussels Award 2016 to promote Polish success stories in Horizon 2020, Warsaw, June 2, 2016
- developing communication activities – promotional materials, NCP Weekly Newsletters, campaigns in social media (Facebook KPK.Polska and Twitter @KPK\_PL) as well as in traditional media, launching a new communication channel KPK\_LIVE) and English-language Bulletin - to promote Polish H2020 potential and success stories.



### VI. Other strategic activities:

- contributing to changing the H2020 remuneration rules
- contributing to shaping content priorities in the H2020 Work Programmes 2018-2020 in cooperation with the Polish expert reference groups – active participation in the H2020 Programme Committees and different EC Working Groups
- contributing to interim evaluation of H2020 (NCP Poland - input paper, con-tribution to the NCP Input Paper prepared by NCP Academy)
- contributing to the Polish Position Paper on Future Framework Programme, incl. “Widening instruments”
- cooperating in order to reach a synergy between H2020 and Structural Funds, advocating the introduction of the Seal of Excellence into the national programmes, supporting the system for Polish Teaming projects
- dedicated support for SMEs in cooperation with the Enterprise Europe Network and consulting companies
- Activities encouraging Polish institutions and experts to be more active in international networks (COST) and partnerships
- Studies and analysis on Polish participation in H2020 and opinions on EU programming documents.
- International cooperation in H2020 (Information Day on Energy and Environment in Kyiv, April 8, 2017 and an active member of EaP Panel on R&I).



**Fig. 6.5.** Signing the agreement between Polish National Contact Point for Research Programmes of the EU (NCP) and KGHM Polska Miedź S.A., photo: KGHM Polska Miedź S.A

Pictured from right to left are: Rafał Pawełczak, Vice President of the Management Board (Development) of KGHM Polska Miedź S.A.; Radosław Domagalski-Łabędzki, President of the Management Board of KGHM Polska Miedź S.A and Prof. Tadeusz Burczyński, Director of IPPT PAN and Zygmunt Krasieński, Ph.D., Director of NCP

**Fig. 6.6.** Signing the agreement between Polish National Contact Point for Research Programmes of the EU (NCP) and Grupa Azoty, photo: S. Duszyńska/NCP

Pictured from right to left are: Grzegorz Kądziałowski, Ph.D., Vice President of the Management Board of Grupa Azoty S.A., Wojciech Wardacki, Ph.D., President of the Management Board of Grupa Azoty S.A. and Prof. Tadeusz Burczyński, Director of IPPT PAN and Zygmunt Krasieński, Ph.D., Director of NCP





## 7. 2016-2017 PUBLICATIONS

The Institute's mission is to conduct high-quality theoretical and experimental research both of fundamental as well as of applicable character in the areas which are in the centre of world science and technology. Their realisation takes place within the framework of wide cooperation with renowned scientific, research and industrial centres in Poland and in the world. In recent years, the research activity has been focused on the issues intensively developed in leading world centres, especially in such areas as: advanced problems in modern mechanics and material engineering; new multifunctional and multi-component materials; nanomaterials and nanoflows; intelligent technologies; bioinformatics and ultrasound diagnostics in medicine. The combination of advanced experimental research conducted on high-class equipment and mathematical methods with extensive knowledge in the field of computer science allows, among others, for the creation of advanced computer simulations

enabling the analysis of very complex states and processes occurring both in complex materials and in biological systems.

These research activities are reflected in several publications by our scientific staff. Each year the number of high quality papers published by our researchers is increasing (151 in 2016 and 167 in 2017). Especially worth mentioning here is the number of publications in leading international journals, indexed in the internationally recognised Thomson Reuters Web of Science (WoS) data base (102 in 2016 and 133 in 2017). A significant part of them appeared in journals from the most prestigious Q1 and Q2 quartile scores set according to Thomson Reuters classification. A number of publications appeared in other journals, scored by Polish Ministry of Science and Higher Education (MNiSW). About 40 percent of our publications were created in cooperation with foreign research centres. The diagram below illustrates the publication activity of the Institute during recent years. It resulted in many joint projects, research, exchange of scientists and other forms of cooperation.

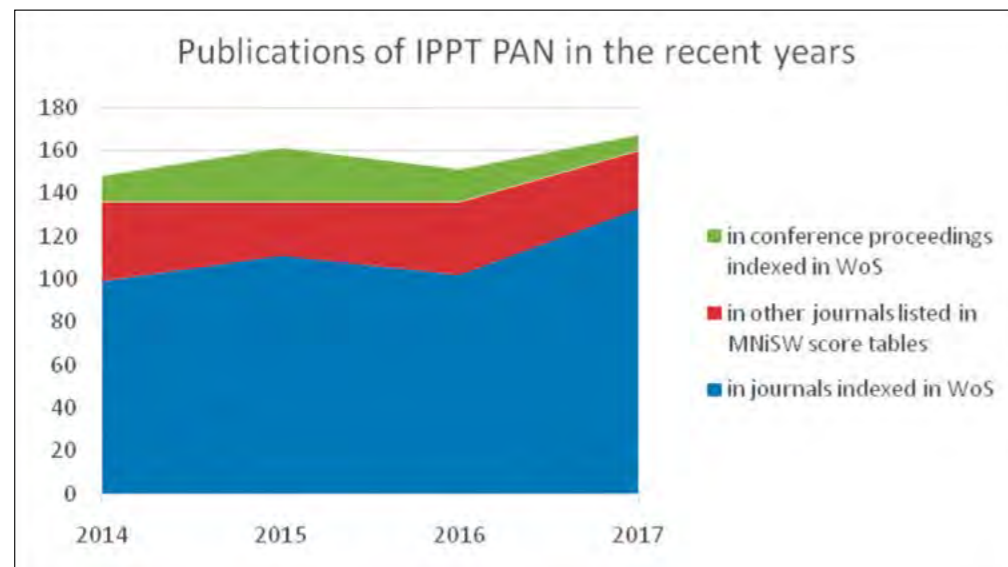


Fig. 7.1. Publications of IPPT PAN in the recent years

The full list of publications issued between 2016-2017 is presented at the end of this Biennial Report.  
(page 124)

## 8. TOWARDS INNOVATION AND IMPLEMENTATION

Fast increase in state-of-the-art technical equipment and facilities of the IPPT PAN (including research and development infrastructure) has resulted in taking up very advanced scientific research projects in order to transfer our knowledge and know-how into the industry. Owing to the individual competence, potential and scientific successes of our employers, the IPPT PAN is able to carry out projects by developing the most innovative solutions, their further implementation and the modernisation of the already existing technical conditions, providing competitive edge for industrial enterprises, as well as scientific units.

Below are examples of how the effects of scientific, research and development projects were used in practice, between 2016-2017.

### DEVICE EXAMINING DEFORMATION BEHAVIOUR OF THIN BRASS SHEETS UNDER TENSION-COMPRESSION TESTS

None of the known systems for the prevention of thin metal sheet buckling under compression takes into account the influence of friction force on the course of behaviour of the tested specimen subjected to monotonic compression loading, as well as tension-compression cyclic loading, including the number of cycles. Such possibilities are now offered by a device developed by the IPPT PAN team of employees under the supervision of Prof. Zbigniew L. Kowalewski, a unique device, the only one known in the world. Developed at IPPT PAN, the invention is patent licensed under the 398245 patent number of 2012-02-27, entitled: *Przyrząd do badania wytrzymałościowych cienkich, płaskich próbek materiałów konstrukcyjnych, zwłaszcza blach* (Device for testing the strength of thin, flat samples of construction materials, especially metal sheets) and is listed at the Republic of Poland Patents Office official website.



Fig. 8.1. Mobile case set

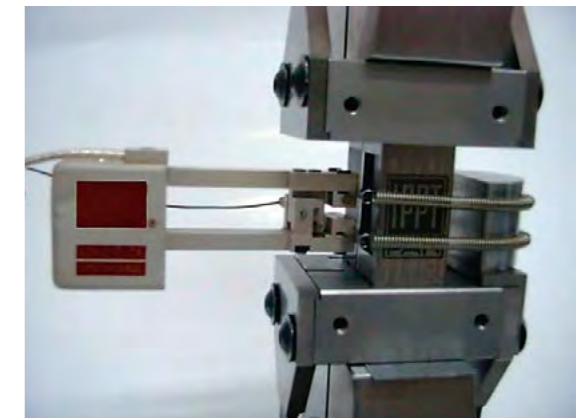


Fig. 8.2. Device examining deformation behaviour of thin brass sheets under tension-compression tests

The legal owner of the patent is exclusively the IPPT PAN. The developed version of the device examining samples of thin brass sheets undergoing considerable deformations under cyclic tension-compression loading was sold to Arcelor-Mittal, an American company based in East Chicago, USA, and the brass testing methodology using the developed version of the device was implemented in the company's laboratory. The implementation comprised of carrying out a weekly training for the users from Arcelor-Mittal in East Chicago by the IPPT PAN employees on the service and usage of the device and on the test cycle launching on the testing machine, with the use of the device. The testing capabilities of the fixture were then published in *Strain* (Vol.50, pp.174-183, 2014) and in *Journal of Theoretical and Applied Mechanics* (Vol.53, No.3, pp.757-762, 2015).

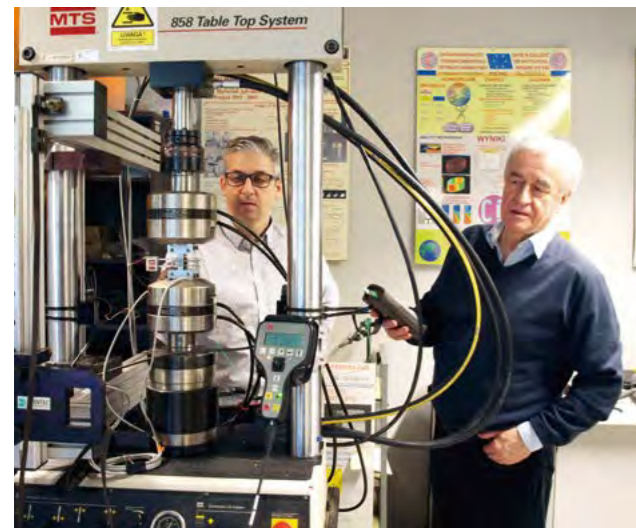


Fig. 8.3. Working on the invention - research carried out by engineers (M. Wyszowski and A. Chojnacki) at the Division of Strength of Materials at IPPT PAN, supervised by Prof. Zbigniew L. Kowalewski



Fig. 8.4. USPlatform – A Versatile Ultrasound Research Platform

### USPLATFORM – A VERSATILE ULTRASOUND RESEARCH PLATFORM

A fast increase in computational performance of new GPU chips enables a change in the paradigm of traditional hardware based signal processing for ultrasound image formation. Hardware based beamforming is a limiting factor in the implementation of new imaging methods — esp. synthetic aperture, vector Doppler and elastography. A direct access to the raw RF ultrasound echoes empowers the implementation of these advanced signal processing algorithms, whereas powerful GPUs facilitate and speed-up the development process.

The Laboratory of Professional Electronics, led by Marcin Lewandowski, Ph.D., proposed a novel system architecture and developed a complete platform solution resulting in a programmable GPU-based ultrasound research device.

A Versatile Ultrasound Research Platform is a fully programmable research ultrasound scanner based on a novel architecture optimised for direct raw RF signal streaming and processing on GPUs. PCIe communication infrastructure enables scalability of the number of acquisition channels (64–192) and processing power (1–5 GPUs). Direct access to raw RF data (i.e. channel data) and real-time software processing on the GPUs gives new possibilities for research and evaluation of ultrasound algorithms and methods. The system is fully software programmable – including transmit/receive schemes and processing functions). Standard software tools CUDA/OpenCL can be used to develop and integrate new algorithms into the Platform's processing framework. A low-level API can be easily used from many popular research/development environments (e.g. Matlab®, Python).

#### Applications

- Research and development of new ultrasound methods and processing algorithms for the application in medical diagnostics and non-destructive material testing

- Implementation and testing of advanced processing algorithms on GPUs for real-time ultrasound imaging
- Evaluation of new methods in real-world conditions
- Validation and comparison of various methods/algorithms on the very same platform
- Fusion of ultrasound signal processing with accelerated machine learning – enabled by Nvidia® GPU and machine learning frameworks (e.g. TensorFlow, Nvidia® cuDNN).

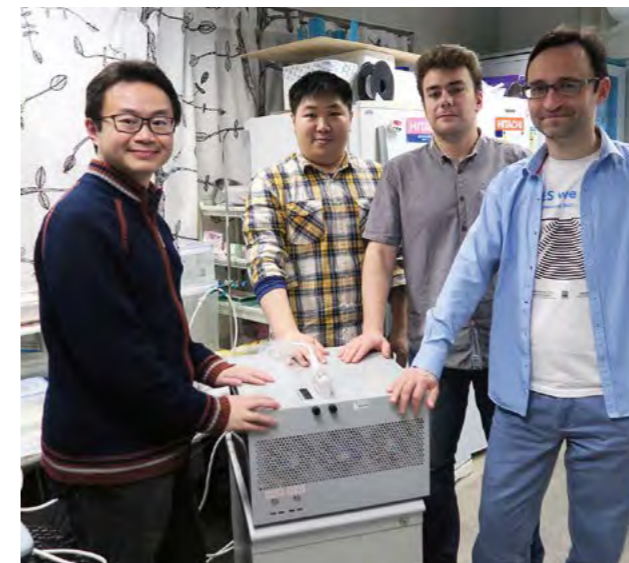


Fig. 8.5. Marcin Lewandowski, Ph.D. and Mateusz Walczak from IPPT PAN, handing in USPlatform at Hong Kong University. (left to right): Prof. Alfred C. H. Yu and Billy Y. S. Yiu

The system was delivered to the University of Hong-Kong and commissioned in the Biomedical Ultrasound Laboratory of the Dept. of Electrical & Electronic Engineering. A close collaboration with the research group of Prof. Alfred C. H. Yu resulted in the implementation of many advanced methods of flow visualisation on the USPlatform. The system is actively used for evaluation and testing of computational intensive algorithms for medical imaging and blood flow estimation techniques. The IPPT PAN signed a licence agreement with a spin-out company - us4us Ltd. ([www.us4us.eu](http://www.us4us.eu)), which deals with the production, sales, and technical support of the USPlatform.

### ADAPTIVE IMPACT-ABSORPTION SYSTEMS FOR AEROSPACE APPLICATION

The development of adaptive systems at the Department of Intelligent Technologies started from the works on the innovative constructions of adaptive aircraft landing gears, under the ADLAND project and in cooperation with partners from the industry, i.e. EADS (now: Airbus Military), Messier-Dowty (now: Messier-Bugatti-Dowty) and PZL-Mielec (now: Lockheed Martin), resulting in the creation of the first in the world, adaptive shock absorber (Fig. 8.6), which was tested on a real aircraft, M-28 SKYTRUCK (Fig. 8.7), produced by PZL-Mielec. The development of the technology of adaptive landing gear was supervised by the current IPPT PAN employees, i.e. Prof. Jan Holnicki-Szulc and Zbigniew Wolejsza Ph.D., D.Sc. The above-mentioned landing gear developed with the help of the IPPT PAN is in constant production and use in those aircrafts.

The ADLAND project helped to gain experience in the area of adaptive impact absorption systems by the Divisions of Safety Engineering (ZTI IPPT PAN) team and contributed to closer cooperation between the team and the industry on creating safer aircrafts.



Figs. 8.6. and 8.7. Adaptive suspension landing gear mounted on M28 SKYTRUCK (left) and the aircraft, equipped with the adaptive landing gear, during landing (right)

Also worth noting are, developed in cooperation between the IPPT PAN and Adaptronica Sp. z o.o., impact absorption systems using pneumatic airbags as elements of the AdBag System. The AdBag System allows for the protection of drones from crashing after emergency situations, such as drive system failure.

Adaptiveairbags (Fig 8.8) are immediately activated after drone failure detection, and upon landing crash they absorb shock at the acceptable impact overloads. The simulation tests results, i.e. the effects of impact during drone crash on a car roof are shown in Fig. 8.9. The product met with interest from small-size companies producing drones.

The technologies developed in the AdBag System can also be easily applicable to small-size passenger aircrafts (General Aviation). Currently, small aeroplanes are equipped with parachutes, serving as emergency rescue systems. However, they do not fully protect the aeroplane from structural damage during crash due to excessive speed while falling (c. 10m/s). It is the application of the AdBag system complementing the parachute emergency rescue system that can fully protect the aeroplane from damage.

Work was being carried out to apply the AdBag System to the Flaris LAR-1 aircraft (Figs 8.10-12) as a system significantly decreasing the structural response to an impact scenario during landing with the help of an emergency rescue parachute. The production of AdBag System for Flaris-LAR1 aeroplanes, in cooperation with the IPPT PAN, was planned to start in about 3-4 years.



Fig. 8.8. Sensors-equipped airbag as an element of the AdBag System

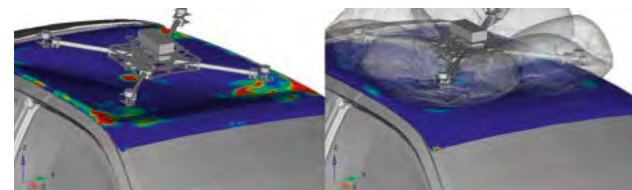


Fig. 8.9. Simulation tests results of the impact of a drone without an airbag (left) and with an AdBag airbag (right) on to the car roof



Figs 8.10-12 show the representatives from the IPPT PAN standing by the FLARIS LAR-1 aeroplane in Metal-Master company in Podgórzyn: Assoc. Prof. Piotr Kowalczyk - Deputy Director for Planning and Administration, Zbigniew Wolejsza, Ph.D., D.Sc, Prof. Krzysztof Wiśniewski, Andrzej Siemaszko, Ph.D., Bartłomiej Błachowski, Ph.D., and Rafał Ładziński - President and the creator of FLARIS LAR-1 programme. (photo credit: Piotr Tauzowski, Ph.D.)



Figs 8.10-8.12. Flaris LAR-1 - apart from emergency parachute rescue system, additional application of AdBag System is planned to be added for the structural damage protection of aircraft during emergency landing with a parachute. It is estimated that every produced aeroplane will be equipped with the AdBag System

## CERTIFIED QUALITY MANAGEMENT SYSTEMS



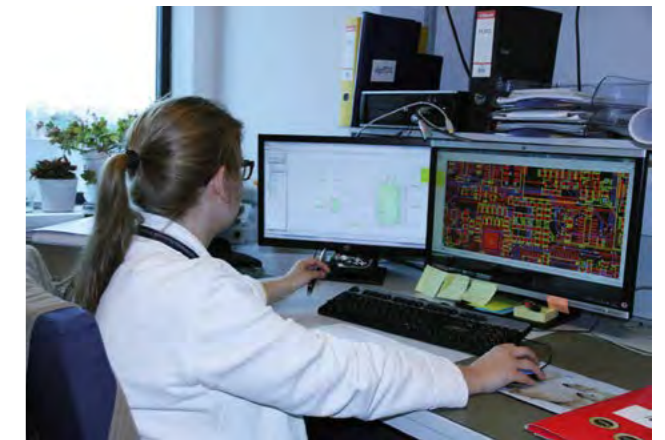
IPPT PAN (the Laboratory of Professional Electronics) proudly announced its successful implementation of two certified management systems:

- ISO-9001:2009 – Design and development, manufacture, service and training in the area of electronic systems and software;
- ISO-13485:2012 – Design and development, manufacture and service of medical devices, and training for users of medical ultrasonic devices.

The obtained certification validates our professionalism and enables us to design, develop and introduce new medical devices to clinical practice. We are proud of being involved in the development and implementation of two medical systems: a transcranial Doppler system digiTDS and a high-frequency ultrasound scanner uScan2. We work closely with industrial partners and provide them with expertise, R&D and electronic design services.

Our laboratory develops advanced electronic systems and digital signal processing algorithms for demanding medical and industrial applications. Our specialisation is in the area of ultrasound methods and instrumentation, including medical diagnostics, as well as industrial non-destructive testing of materials and structures.

Together with the other divisions of IPPT PAN, we provide a unique blend of R&D services and commercial system development – bridging the gap between research and the market. Our motto is to ensure the highest level of science and industrial-grade technical solutions for real-world applications.



Figs 8.13-14. The Laboratory of Professional Electronics, IPPT PAN

Contact:  
Marcin Lewandowski, Ph.D.  
e-mail: mlew@ippt.pan.pl

# 9. 2016-2017 PROJECTS

## RESEARCH PROJECTS

For dozens of years, the Institute has been conducting research on fundamental, theoretical and practical areas of science. Purpose-orientation, high effectiveness and openness to new ideas have been the key contributors to winning numerous prestigious grants for our research projects, awarded to our employees by many Polish and foreign organisations and institutions, such as the National Science Centre, the National Centre for Research and Development, the Polish Science Foundation, the Polish Ministry of Science and Higher Education, and the European Commission within the Horizon 2010 Programme, among many others. In 2016 and 2017, the Institute conducted as many as 118 projects.

## SELECTED RESEARCH PROJECTS

### DURABILITY AND EFFICIENCY OF CONCRETE SHIELDS AGAINST IONIZING RADIATION IN NUCLEAR POWER STRUCTURES", 2014-2017

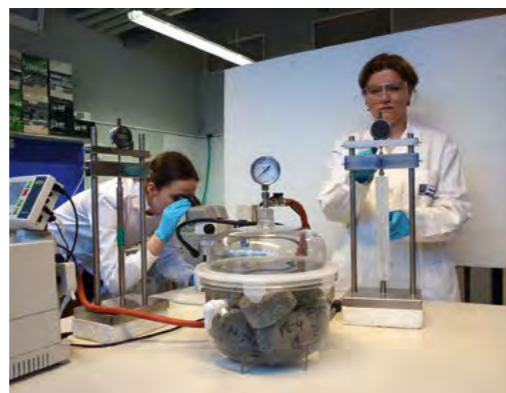
**Prof. Michał A. Glinicki, coordinator**

The aim of the Project was to develop design methods and define criteria for assessing the durability of concrete shielding structures against harmful ionizing radiation in nuclear power facilities. Material laboratory tests and computer simulations were carried out, new cements with special properties were developed, mixing the design and technology for industrial manufacturing of shielding concrete. The technology was verified by testing concrete properties in structural elements using innovative methods of testing: the neutron and gamma radiation shielding, concrete microstructure, mechanical and physical properties, and, especially, their long-term stability at radiation and thermal-moisture exposure. The microscopic method of assessing reactive minerals in aggregates, along with an accelerated assessment of their reactivity with alkali in concrete, allowed the elimination of ingredients with insufficient durability. The numerical solution of inverse heat transfer problem in hardening concrete enabled determination of thermophysical

properties of shielding concrete and a safe temperature field in a massive structure. Technical guidelines for the design and construction of concrete shields against ionizing radiation were developed for designers, manufacturers and radiology protection administration. The original material solution for radiological shields is covered by a patent application.



This work was supported by the National Centre for Research and Development (NCBiR) PBS2/A2/15/2014.



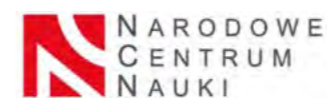
**Fig. 9.1.** Microstructural observation and physical testing at the laboratory construction materials, coordinated by Prof. Michał A. Glinicki

### MUSINT — MULTISCALE NUMERICAL MODELLING OF SINTERING PROCESSES, 2014-2018

**Prof. Jerzy Rojek, coordinator**

The project is aimed to develop a multiscale model considering the three scales relevant for sintering: atomistic, microscopic and macroscopic. Sintering is a fundamental process of powder metallurgy consisting, in consolidation, of ceramic and metallic powders at elevated temperature. During sintering, processes at different levels interact with one another. Macroscopic changes, such as the conversion of particulate material into a solid compact body, the change of mechanical properties, shrinkage, density change, are all the result of phenomena occurring at the microscopic level: the forming and growth of connections between particles, change of the inter-particle distance, grain rearrangement, and gradual reduction and elimination of porosity. The microscopic phenomena are, in turn, the result of processes of diffusion occurring at the atomistic level.

In the project, developed constitutive models at different levels have been linked to one another. Molecular simulations at atomistic level provided important insights and guidance to properly describe the sintering phenomenon. Micromechanical discrete element model of sintering made it possible to study phenomena occurring at the microscopic level. The macroscopic results, obtained by finite element simulations, have been validated by experimental studies, which provided much data useful for basic research of the sintering process.

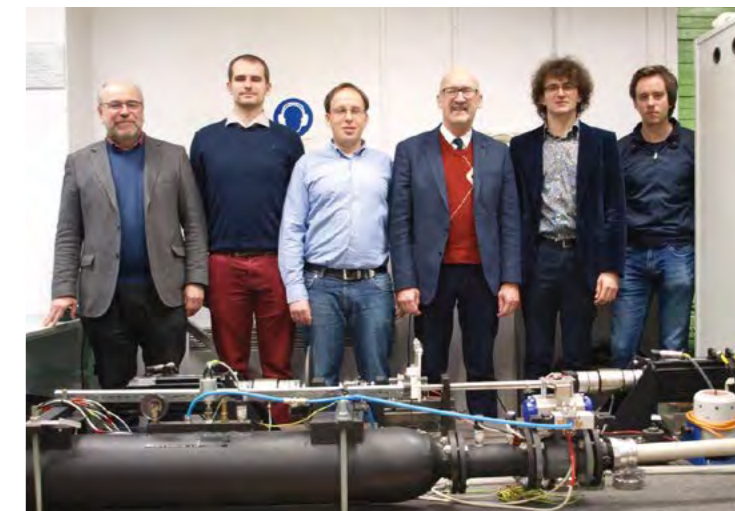


This work was supported by the National Science Centre, 2013/11/B/ST8/03287.

### INNOVATIVE TECHNOLOGY FOR COPPER ORE PREPARATION FOR FLOTATION WITH APPLICATION OF HIGH-ENERGY COMMINUTION TECHNIQUES, 2015-2017

**Assoc. Prof. Tomasz Szolc, coordinator**

The general purpose of this project was the development of innovative technology of copper ore preparation for flotation using high-energy comminution techniques in order to replace the quasi-static low-efficient two-stage wet grinding, applied, until then, with the one-stage dynamic dry grinding made by a high-speed beater mill. This new technology was completely different from the then-used methods for non-ferrous metal ore treatment. Namely, it applied rotating beater-wheel tools with high kinetic energy, which, by means of a multiple beating of grains and milled grain bouncing of the mill casing, enabled us to realise the process much more effectively and with smaller energy consumption. In order to achieve this target, theoretical fundamentals of impact-type ore comminution have been developed by means of advanced computational methods.



**Fig. 9.2.** The project team at the laboratory at IPPT PAN. From left: Prof. Jerzy Rojek, Michał Jakub Marijnissen, Cezary Graczykowski, Ph.D., Assoc. Prof. Tomasz Szolc (Coordinator), Robert Konowrocki, Ph.D., Dominik Pisarski, Ph.D.

A design of the high-speed beater mill adopted to copper ore grinding was intensively supported by the thorough static and electrodynamic analyses. Owing to these works, a prototype installation for high-energy ore preparation has been built. The introductory tests performed using this device are very promising. IPPT PAN realized this project in cooperation with the Institute of Non-ferrous Metals in Gliwice, the Faculty of Production Engineering of the Warsaw University of Technology, the KGHM-Cuprum Research and Development Centre, and with the FPM S.A. industrial company.



This work was supported by the National Centre for Research and Development (NCBiR) and the KGHM Polska Miedź SA, CuBR/I/3/NCBR/2014.

**THE MULTI-SCALE DYNAMICS OF SIGNAL TRANSDUCTION: DISSECTING THE MAPK PATHWAY, 2015-2018**

**Prof. Tomasz Lipniacki, coordinator**

We formulated a computational model for a canonical MAPK (mitogen-activated protein kinase) cascade,  $GF \rightarrow RAS \rightarrow RAF \rightarrow MEK \rightarrow ERK$ , to investigate how inter-linked positive and negative feedback loops process GF (growth factor) signals into ERK activity pulses of constant amplitude but dose-dependent duration and frequency. We have showed that the effect of a given negative feedback depends on its position with respect to a positive feedback loop. Furthermore, a combination of the positive feedback of fast chemical kinetics that involves slow-diffusing membrane components with negative feedbacks of slow chemical kinetics that involves faster diffusing cytoplasmic components leads to LEGI (local excitation/global inhibition) dynamics, which allows the cascade to translate paracrine signals into spatially non-uniform ERK activity pulses.

By combining experimentation with mathematical modelling, we have identified how RAF1, a RAF isoform, acts both as a kinase for MEK and an inhibitor of ROK $\alpha$ , a regulator of cytoskeletal rearrangements. We have shown that these two activities are controlled by the formation of task-specific phosphorylated forms of RAF1 arising due to its interactions with another RAF isoform, BRAF. The proposed mechanism precisely coordinates the timing of proliferation with changes in cell shape, adhesion, or motility. Our results were published in the Scientific Reports and Science Signaling.



This work was supported by the WWTf - Vienna Science and Technology Fund, MA14-049.

**INVESTIGATION OF THERMOMECHANICAL PROPERTIES OF GUM METAL - A NEW TITANIUM ALLOY WITH HIGH ELASTO-PLASTIC PROPERTIES, UNKNOWN DEFORMATION MECHANISMS AND GREAT POTENTIAL FOR PRACTICAL APPLICATION, 2015-2018**

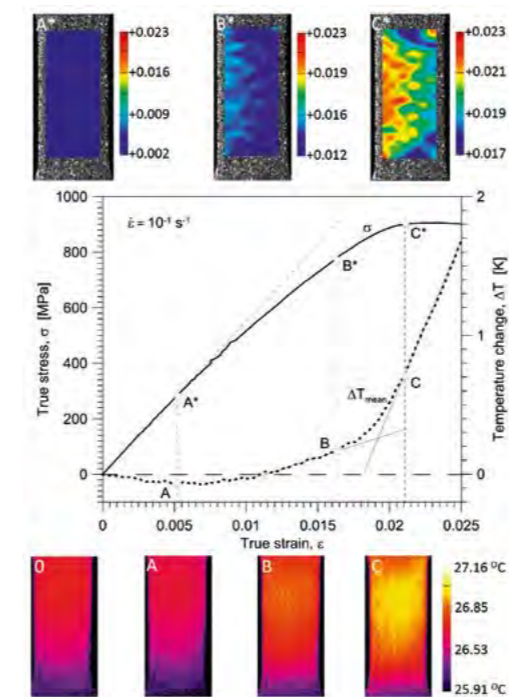
**Assoc. Prof. Elżbieta Pieczyska, coordinator**

The project concerns the investigation of mechanical and thermomechanical properties of new multifunctional Ti alloy with unique properties, named Gum Metal, developed in Japan in 21st century. The alloy properties create a huge potential of application in biomedical, automotive, aeronautic and sports industry. Digital image correlation (DIC) and sensitive infrared thermography (IRT) allowed to determine strain and the related temperature changes with high accuracy. The obtained results confirmed ultra-low elastic modulus (near 60 GPa) and high strength (over 1000 MPa). Comparison of the mechanical and thermal results allowed analysing Gum Metal thermomechanical behaviour at various loading stages. It has been found that the maximal drop in temperature, which corresponds

to the yield limit of materials, is related to significantly lower strain value, in contrast to the obtained high limit of reversible deformation. Yet, just over the strain corresponding to the drop in temperature ( $\approx 0.005$ ), the specimen temperature increases, which proves the dissipative character of the deformation also in its mechanically reversible range. It means that the Gum Metal large reversible deformation should not be, in fact, called „non-linear elasticity”, due to the presence of  $\omega$  and  $\alpha$  phases induced during the fabrication and their related exothermic phase transformations activated by the loading. The analysis of strain and temperature distributions showed that the increase in the strain rate affects both the onset and development of the strain localisation process.



This work was supported by the National Science Centre, 2014/13/B/ST8/04280



**Fig. 9.3.** Initial stage of the stress  $\sigma$  and mean temperature changes ( $\Delta T_{mean}$ ) vs. strain under tension at strain rate of  $10^{-1} s^{-1}$  coupled by a strain distribution obtained by DIC algorithm (above) and temperature distribution obtained by IRT (below)

**ULTRASONIC STREAMING-AIDED THROMBOLYSIS, 2015-2018**

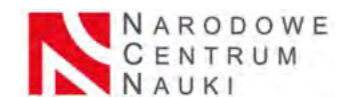
**Wojciech Secomski, Ph. D., coordinator**

The aim of the study is to evaluate the process of thrombolysis by the interaction of the thrombolytic drug and the ultrasonic waves. Presumably, the mechanism supporting the accelerating process of clots' dissolving effect is the phenomenon related to the acoustic streaming microflow in the vicinity of the thrombus. The scope of work involves the study of the influence of frequency, sound pressure, intensity and power of ultrasonic wave and the streaming velocity on the process of dissolution of thrombi.

The efficacy of thrombolysis was assessed on the basis of the measurement of time for a complete dissolution of blood clots, weight of blood clots and clot breakdown products analysis.

The method was based on laboratory studies of the process of dissolution of thrombi by means of acoustic streaming. Blood clots derived from animal blood were placed on the multi well plates used to culture the cells in vitro. Sonothrombolysis process was analysed as an interaction of 40 kHz - 10 MHz ultrasonic waves and thrombolytic drug – tissue plasminogen activator.

The result of the work has been the detailed examination of the phenomenon of thrombolytic drug interaction with ultrasound and the analysis of the impact of the streaming to this process.



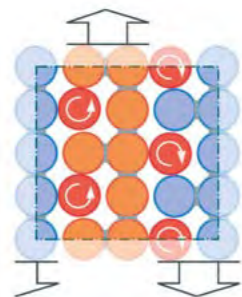
This work was supported by the National Science Centre, 2014/15/B/ST8/04345

**MICROMECHANICS OF PROGRAMMABLE MATTER, 2012-2017**

**Jakub Lengiewicz, Ph. D., coordinator**

The purpose of the project was to make progress in the modelling and control of programmable matter (PM) — a class of future meta-materials, composed of microscopic active modules. Through proper programming of the modules, objects made of PM could potentially change shape, vary their physical properties, or actively respond to environmental stimuli. The concept itself was potentially very attractive with respect to prospective futuristic applications, one of which could be a shape-shifting device to be used in communication or entertainment to physically reproduce virtual (moving and interacting) entities.

As yet, shape-shifting systems, which include reconfigurable robots, remain in their infancy. This is not only due to the difficulty of building a sub-millimetre-size robot of required functionality, but also due to the lack of effective reconfiguration algorithms that would enable the co-operation of millions of densely-packed robots towards the realisation of a given global task, such as changing shape or performing mechanical work. In the project, we addressed the latter problem. The core idea relied on developing special transforming microstructures, composed of interacting robotic modules. The proposed algorithms that operated on these microstructures assured the necessary mechanical robustness and performed effectively in terms of reconfiguration time and computational effort.



This work was supported by the National Science Centre, 2011/03/D/ST8/04089.

**DEVELOPMENT OF BIOACTIVE, HYBRID MATERIAL FOR ACL LIGAMENT REGENERATION, 2013-2016**

**Dorota Kołbuk-Konieczny, Ph. D., coordinator**

Although the benefits of practicing sports are commonly known, little is said about the risk of getting an injury. Children and women over 40 have a high risk of knee ligament injury, which can be caused by running, football, skiing, squash etc. It is difficult to imagine how painful the ligament injury can be, or in consequence, how big the deterioration in quality of life it may cause.

The ligaments connect the bones, providing stabilization of the joints. The current treatment of knee injuries is not as effective as we would expect. The standard procedure is to perform an autograft — the patient's own tissue is cut and the injured ligament is replaced. However, in case of serious and extensive injuries, there might not be enough tissue which could be used for this purpose. Additionally, extracting tissue from a healthy ligament might also lead to the ligament weakening. Therefore, another option may be to use synthetic material, available on the market. However, due to the low biocompatibility and strength of materials, reoperation is very common in such cases.

The project involved the development of a biodegradable scaffold for the regeneration of knee ligament (ACL). Utilizing knowledge in the fields of natural sciences, mechanics, biology and medicine, the hybrid product was characterized by its architecture, chemical structure and mechanical properties that mimic natural tissue. In the long run, using innovative scaffolding will allow to regenerate ligaments. The product will then biodegrade and all its components will be removed by the metabolic system.

**DROPS, SYSTEMS FOR SAFE AIRDROP, 2015-2019**

**Rami Faraj, M.Sc., coordinator**

The project concerns the development of shock-absorbing devices for airdrop systems. The general goal is to carry out the feasibility study of the elaborated techniques of cargo touchdown mitigation. Within the project, modelling and simulation as well as experimental testing of demonstrators are conducted. Works include the development of impact mitigating packages and absorbers used as a suspension of cargos. Numerical simulations have proved high performance of the proposed devices. The concepts have been successfully verified in laboratory tests (Fig. 9.7.). In order to reduce the speed of the cargo discharged from an aircraft, an auto-rotating rotor as an alternative solution to parachute has been investigated. Scenarios of the cargo airdrop have been developed and the concept of a suitable rotor pre-rotation system has been developed.

Graft prototype was under development and it was coming to an end. In-vivo studies were planned for the following weeks.

Graft prototype is under development and it is coming to an end. In few weeks in-vivo studies are planned.



This work was supported by the National Centre for Research and Development (NCBiR), LIDER/388/L-6/14/NCBR/2015.



Fig. 9.4. Jarosław Gowin, Minister of Science and Higher Education, hands in the award to Dorota Kołbuk-Konieczny, Ph. D. at the award ceremony



Fig. 9.5. Dorota Kołbuk-Konieczny, Ph. D. at the laboratory at IPPT PAN

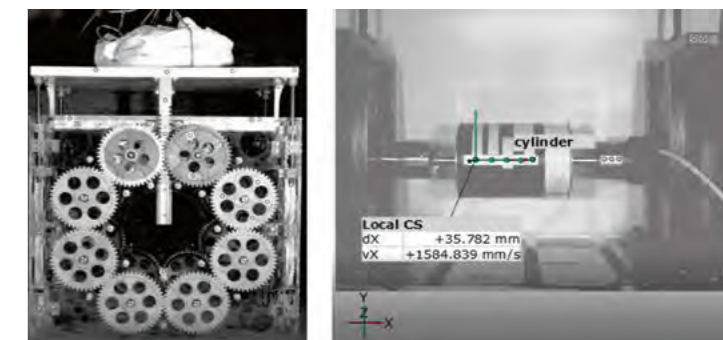


Fig. 9.6. Fast-camera images of tested demonstrators – the impact mitigating package on the left, one of the developed absorbers on the right



This work was supported by the Ministry of Science and Higher Education, DI2014 000944.

**SUPER HARD THIN LAYERS OF BORIDES OF TUNGSTEN — THE EFFECT OF MICROSTRUCTURE AND CHEMICAL COMPOSITION ON PHYSICOCHEMICAL PROPERTIES, 2016-2018.**

**Justyna Chrzanowska-Giżyńska, M.Sc., coordinator**

If devices such as space shuttles, gas turbines or harvesters cause delight at the possibilities of human mind, they usually refer to the constructor's imagination. However, their construction would be impossible without materials that can withstand heavy loads or work in harsh conditions. Thus, the need emerged to increase their performance and to create a new, chemically inert, group of materials with high hardness and fracture toughness. The theoretical calculations show that tungsten borides have hardness comparable to that of cubic boron nitride (c-BN) and diamond. However, the difficulty in the fabrication of single phase material using conventional methods is the main drawback of this group of ceramics. In order to overcome this problem, the material can be deposited as a thin layer, for instance, in the magnetron sputtering process. This technique allows one to obtain high deposition rates, guarantees reproducible conditions, and gives the possibility of modifying the composition of the film. So far, the research (carried out within the project), has lead to the deposition of layers highly wear-resistant, having good thermal stability, and 70 GPa hard. The objective of the present investigation is to analyse the effect of microstructure on the hardness of deposited layers.



This work was supported by the National Science Centre, 2015/19/N/ST8/03928.

**OTHER PROJECTS**

The National Contact Point for Research Programmes of the EU is actively involved in projects financed by the European Commission under the 7th Framework Programme and the Horizon 2020. The NCP in Poland is an active partner of the European NCP network projects, especially through the organisation of brokerage events, participating in partner search services and providing expertise in the area of R&I policy. The NCP in Poland has a wide experience in the realisation/coordination of the International Cooperation (INCO) projects focused on the Eastern European, Black Sea, Central Asian countries, and the USA, as well as the projects in the area of education and training for research managers and administrators financed by the Norwegian Grants and EEA Grants.



**Fig. 9.7.** Horizon 2020 Space Information Day and Brokerage Event in Warsaw, December, 13-14, 2017. The Conference was co-organised by the National Contact Point for Research Programmes of the EU (NCP), photo: S. Duszyńska, NCP



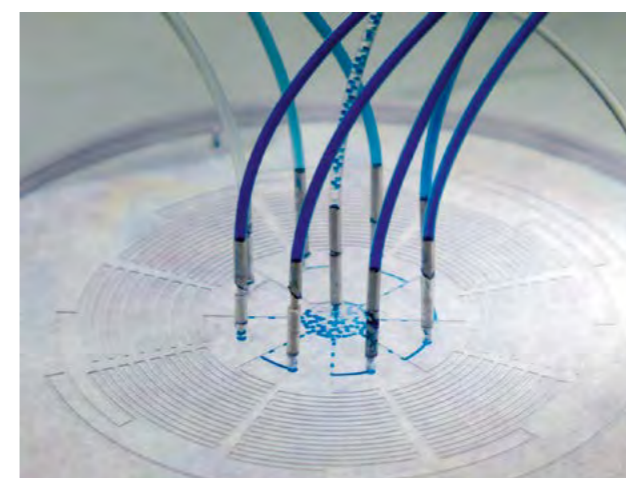
**Fig. 9.8.** Leader of the meeting From left: Janusz Stec (Counsellor to Minister, Ministry of Economic Development), Prof. Tadeusz Burczyński (Director of IPPT PAN), Zygmunt Krasinski, Ph.D. (Director of NCP), photo: S. Duszyńska/NCP

**SELECTED YOUNG SCIENTISTS ACHIEVEMENTS IN 2016-2017**

**WINNERS OF THE FIRST TEAM (FNP) CONTEST:**

**Piotr Korczyk, Ph.D., D.Sc.**

The winning project is titled "Digital operations on droplets embedded into smart microfluidic architectures for applications in medical diagnostics and biological research".



**Fig. 9.9.** Microfluidic system producing droplets of varying reagent concentrations

The project's goal is to develop smart microfluidic architectures with precise instructions embedded into the design of the chip. In microfluidics, a tiny droplet (less than 1 microlitre) can be treated as an isolated biochemical reactor. Generation of a large number of such droplets, coupled with the ability to mix chemical reagents inside droplets, enables conducting long series of experiments simultaneously. In this project, the microfluidic solutions will be developed, which on the one hand will provide high precision of operations on droplets, and on the

other hand will be easy to implement in Lab on Chip devices. This will be achieved through the construction of special geometries of the microfluidic channels inducing the formation of droplets and then the self-regulation of the flow of droplets resulting in the spontaneous execution of specific operations. The solutions developed in the project will be applied to elaborate an automated device that implements any sequence of operations on droplets. This programmable, micro-laboratory will allow for conducting of biological testing or diagnostic procedures outside a specialised laboratory.

**Michał Komorowski, Ph.D.**

The winning project is titled "Deciphering biochemical signalling to inform more efficient therapeutic strategies". The main goal of this proposal is to improve our understanding how cellular signalling processes can derive a variety of distinct outputs from complex inputs, and how these mechanisms can be harnessed to glean therapeutically useful behaviour. Current tools of information theory are applicable for very small systems only and have, therefore, limited use in modelling of biological systems. To overcome this limitation and achieve this ambition novel analytical and computational tools of mathematical information theory are required, which are suitable to reflect the complex biochemistry of signalling processes. We will make use of concepts of statistical inference theory not used so far in the context of biochemical signalling. The new mathematical tools will open novel approaches to address essential theoretical aspects of signal transduction, including receptor theory.



These works were supported by the Foundation for Polish Science

**WINNERS OF THE HOMING (FNP) CONTEST:**

**Izabela K. Piechocka, Ph. D.**

The winning project is titled "The effect of shear flow on fibrin cloth structure and fibrin-platelets interactions" and its goal is to monitor in situ shear flow-induced changes in the bulk structure of fibrin networks with and without embedded platelets, as a model system that mimics blood clotting in vivo.

Blood clotting prevents extensive bleeding in response to blood vessels injury. Inside the body, the formation of blood clots takes place in the presence of flowing blood that exerts continuous shear forces on the whole clot structure, including its two main components: fibrin and platelets.

Therefore, in order to resist shear flow deformations, a blood clot has to be very strong and elastic. These features are provided by fibrin network that on its own can stiffen up to 1000-fold, while its constituent filaments can be stretched even up to 4-fold their original length.

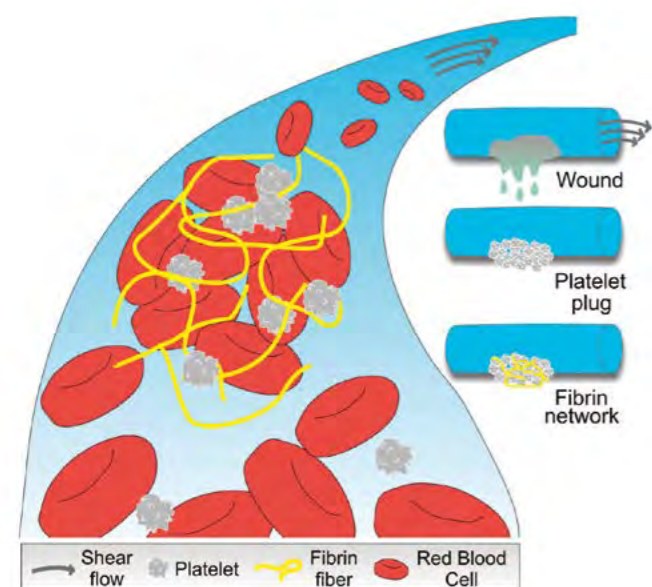


Fig. 9.10. Fibrin forms a mesh of long and flexible filaments that overlay blood platelets at the site of injury

Despite decades of studying, the exact role of the blood flow in the macroscopic fibrin network organization and the nanoscale fibrin-platelets interactions still remains elusive. Within this project we will reconstruct three-dimensional fibrin networks and subject them to continuous shear flow using a special flow chamber that will be placed on the stage of a light microscope. Thus, we will be able to monitor in situ changes in fibrin network structure and in spatial organization of platelets' membrane receptors that help cells to adhere to fibrin. This work will help us to improve our understanding of the blood clotting mechanism.



This work was supported by the Foundation for Polish Science



Fig. 9.11. Izabela K. Piechocka, Ph. D. at the microscopy laboratory at the Department of Biosystems and Soft Matter

**WINNER OF THE LIDER (NCBR) CONTEST:**

**Filippo Pierini, M.Sc.**

The winning project is titled "Design, construction and optimization of a combined Atomic Force Microscope and Optical Tweezers instrument for single molecules and nanomaterials characterization".

Force plays a crucial role in physical, biological and chemical processes. The study of forces, involved in molecular and nanomaterial interactions, represents one of the most important contemporary challenges. The knowledge of mechanical forces involved in single molecules, nanomaterials and biological objects activities is fundamental in understanding their structure and function. A few techniques have recently been used to directly measure the forces required to unfold molecules, to quantify mechanical properties of biological tissues and cells, but they are invasive, slow and not precise enough to satisfy the current needs. Therefore, the aim of this project is to develop a hybrid double probe instrument which can be used to achieve these purposes. This equipment will be built by coupling an Atomic Force Microscope (AFM) with another technique capable of manipulating matter at the nanoscale and to control and measure force with high resolution, sensitivity and flexibility: Optical Tweezers (OT). By using this new instrument, it will be possible to detect subnanometer displacements, to measure femtonewton forces and to manipulate biological materials, living cells and nanomaterials in a non-invasive procedure.

The hybrid AFM/OT equipment will make great progress in biophysics and in the study of nanomaterials mechanical properties. AFM/OT will outspread quickly, also in the areas of medicine and molecular biology.



Fig. 9.12. Filippo Pierini, M.Sc. next to the combined Atomic Force Microscope and Optical Tweezers at the laboratory (Department of Biosystems and Soft Matter)



This work was supported by the the National Centre for Research and Development (NCBiR)

**The full list of projects carried out at the IPPT PAN between 2016-2017 is presented at the end of this Biennial Report (page 137).**



# 10. INTERNATIONAL SCIENTIFIC CO-OPERATION

The Institute has an extensive experience in international co-operation particularly in the area of International Research projects.

## SELECTED PROJECTS UNDER THE AGREEMENTS ON SCIENTIFIC COOPERATION:

**BELARUS**, Belarusian State University, Analysis of ultrasonic signals in imaging of tissue and of tissue phantoms — Assoc. Prof. Barbara Gambin (IPPT PAN);

**BULGARIA**, Institute of Biophysics and Biomedical Engineering, Bulgarian Academy of Science, Sofia, Nonlinear Dynamics of Molecular and Supramolecular Structures — Assoc. Prof. Vasyl Kovalchuk (IPPT PAN);

**CANADA**, Department of Electrical and Computer Engineering, The University of Waterloo, Novel ultrasound methods and instrumentation for medical applications — Marcin Lewandowski, Ph.D. (IPPT PAN);

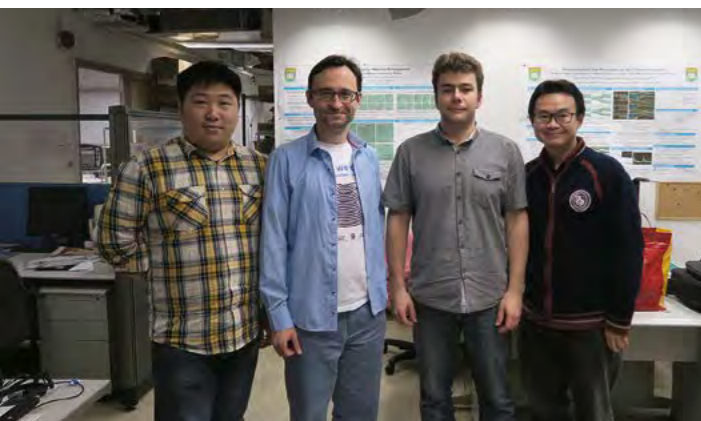


Fig. 10.1. A research visit at the Hong Kong University. Pictured from right to left are: Prof. Alfred C. H. Yu, Mateusz Walczak, Marcin Lewandowski, Ph.D. and Billy Y. S. Yiu

**CHINA**, Department of Electrical and Electronic Engineering, The University of Hong Kong, Development and implementation of a real-time high frame rate

ultrasound imaging methods for complex flow dynamics visualization — Marcin Lewandowski, Ph.D. (IPPT PAN);

**HUNGARY**, Budapest University of Technology and Economics, Robust and reliability based approach in layout optimization — Piotr Tazowski, Ph.D. (IPPT PAN);



Fig. 10.2. A research visit at the Budapest University of Technology and Economics. Pictured from right to left are: Prof. János Lógó, Bartłomiej Błachowski, Ph.D., Piotr Tazowski, Ph.D.

**JAPAN**, Hiroshima University, Department of Civil and Environmental Engineering, Study of structural optimization and reinforcement of the Mobile Bridge — Prof. Jan Holnicki-Szulc (IPPT PAN);

**KOREA, CZECH REPUBLIC, HUNGARY, SLOVAKIA**, Yonsei University, Korea; Czech Technical University, Czech Republic; (Faculty of Civil Engineering); Hungarian Academy of Sciences, Hungary; (MTA Centre for Energy Research); Slovak Academy of Sciences, Slovak Republic; (Institute of Construction and Architecture), The Effect of Chemical Composition of Concrete on Its Long-term Performance in Irradiated Environment Project acronym: V4-KOREA-RADCON — Prof. Michał A. Glinicki (IPPT PAN);



Fig. 10.3. Kick-off meeting of RADCON project carried out by scientists of Visegrad countries and Korea (David Pešek from the Czech Technical University in Prague, Czech Republic, Prof. Michał A. Glinicki from IPPT PAN, Poland, Dr Kyoungsoo Park from the Yonsei University, Korea

**LITHUANIA**, Vilnius Gediminas Technical University, Department of Strength of Materials, Discrete element modelling of materials and particulate flows — Prof. Jerzy Rojek (IPPT PAN);

**ROMANIA**, Institute of Macromolecular Chemistry “Petru Poni”, Akademia Rumunii, Iasi, Investigation of mechanics and structure properties of new multifunctional materials — Assoc. Prof. Elżbieta Pieczyńska (IPPT PAN); Department of Manufacturing Engineering, Technical University of Cluj-Napoca, Prof. Dorel Banabic, Numerical and experimental investigation of metal sheet formability under complex strain paths — Prof. Jerzy Rojek (IPPT PAN); National Institute for Laser, Plasma and Radiation Physics, Boride and nitride coatings prepared by pulsed laser deposition and magnetron sputtering — Prof. Zygmunt Szymański (IPPT PAN);

**RUSSIA**, Institute for Problems in Mechanics of the Russian Academy of Sciences, Moscow, Mathematical models of surface-modified solids and their experimental identification — Assoc. Prof. Stanisław KucharSKI (IPPT PAN); Dorodnitsyn Computing Centre of the

Russian Academy of Sciences, Affine deformable bodies and their applications in quantum and celestial mechanics — Assoc. Prof. Vasyl Kovalchuk (IPPT PAN);

**SLOVAKIA**, Institute of Materials and Machine Mechanics, Slovak Academy of Science, Bratislava, Investigation of concrete matrix composites, shape memory foams and selected aggregates with application of X-ray — Assoc. Prof. Zbigniew Ranachowski (IPPT PAN);

**UKRAINE**, Pidstryhach Institute for Applied Problems of Mechanics and Mathematics of the National Academy of Sciences of Ukraine, Creation of thin modified layers on functional materials by high-energy treatment methods — Neonila Levintant-Zayonts, Ph.D. (IPPT PAN); and Investigations of oriented polymers by light depolarization — Arkadiusz Gradys, Ph.D. (IPPT PAN)



Fig. 10.4. Ion implantation performed during the visit of delegates of the Pidstryhach Institute for Applied Problems of Mechanics and Mathematics of the National Academy of Ukraine. The process is supervised by N. Levintant, PhD. in the Laboratory of IPPT PAN



**Fig. 10.5.** Participants at the Third General Meeting of the International Committee on Irradiated Concrete (ICIC), 7-10 November, 2017. The meeting also gave opportunity to conduct the first meeting of the participants of the RADCON project, carried out by scientists of Visegrad countries and Korea. IPPT was represented by the scientific team led by Prof. Michał A. Glinicki

#### SELECTED OTHER INTERNATIONAL CO-OPERATION (WITHOUT CONTRACT):

**AUSTRIA**, University of Vienna, TU Wien, Prof. Peter Szmolnyan, Synchronization of cell proliferation and motility with the MAPK signaling pathway — Prof. Tomasz Lipniacki, Marek Kocharczyk, Paweł Koceniowski (IPPT PAN);

**BELGIUM**, Department of Mechanical Engineering, KU Leuven, Heverlee (Leuven), Vibroacoustics of poroelastic media — Assoc. Prof. Tomasz Zieliński (IPPT PAN);

**CHINA**, Assoc. Prof. Yonghui An, Dalian University of Technology, Structural health monitoring techniques and modifications of the damage locating vectors method — Bartłomiej Błachowski, Ph.D. (IPPT PAN); Prof. Jilin Hou, Dalian University of Technology, Dalian, Substructuring and local analysis in structural health monitoring — Assoc. Prof. Łukasz Jankowski (IPPT PAN);

Prof. Qingxia Zhang, Dalian Nationalities University, Dalian, Load identification techniques for structural health monitoring — Assoc. Prof. Łukasz Jankowski (IPPT PAN); Prof. Je-Chiang Tsai, National Chung Cheng University, Taiwan, Reaction-diffusion equations on the sphere — Assoc. Prof. Bogdan Kaźmierczak (IPPT PAN);



**Fig. 10.6.** Pictured from right to left are: Prof. Je-Chiang Tsai (National Taiwan Normal University, Taipei) and Assoc. Prof. Bogdan Kaźmierczak (IPPT PAN)

**CZECH REPUBLIC**, Charles University, Prague, Dr. Karel Tůma, Phase-field method in the modelling of martensitic microstructures — Prof. Stanisław Stupkiewicz, Prof. Henryk Petryk (IPPT PAN);

**FRANCE**, Prof. Chaouqi Misbah, Dr. Alexander Farutin, Laboratoire de Spectrométrie Physique, Université Joseph Fourier and CNRS, Grenoble, Dynamics of vesicles and flexible fibers in Poiseuille flow — Prof. Maria Ekiel-Jeżewska, Agnieszka Słowicka, Ph.D., Prof. Eligiusz Wajnryb (IPPT PAN); Freddy Geyer, Ph.D., Thales Alenia Space, Safety in space engineering — Prof. Jan Holnicki-Szulc, Piotr Pawłowski, Ph.D., Cezary Graczykowski, Ph.D. (IPPT PAN); Laboratoire d'Etude des Microstructures et de Mécanique des Matériaux, LEM3 - UMR CNRS, Université de Lorraine, Metz, Prof. Sebastien Mercier, dr Christophe Czarnot, Micromechanical modelling of elastic-viscoplastic heterogeneous materials — Assoc. Prof. Katarzyna Kowalczyk-Gajewska (IPPT PAN); French-German Research Institute of Saint-Louis - ISL, Selected problems of numerical modelling in terminal ballistics — Piotr Pawłowski, Ph.D. (IPPT PAN);

**FRANCE, USA**, Inria Strasbourg, Mimesis Team, dr Igor Peterlik, Indiana University Bloomington, Intelligent Systems Engineering Prof. Paul Macklin, Mechanical stress modelling in cancer cells clusters — Assoc. Prof. Eligiusz Postek (IPPT PAN); Prof. Antoine Sellier, Laboratoire d'Hydrodynamique (LadHyX) École Polytechnique, Palaiseau, France, Prof. François Feuillebois, Laboratoire d'Informatique pour la Mécanique et les Sciences de l'Ingénieur (LIMSI) and CNRS, Orsay, France, Prof. Jerzy Bławzdziwicz, Texas Tech University, Lubbock, USA, High-frequency viscosity of a dilute suspension of elongated particles in a linear shear flow between two walls — Prof. Maria Ekiel-Jeżewska, Prof. Eligiusz Wajnryb (IPPT PAN);



**Fig. 10.7.** An exhibition booth at the IEEE International Ultrasonics Symposium 2016 in Tours, France (Marcin Lewandowski Ph.D. and his team)

**GERMANY**, Fraunhofer-Institut für Kommunikation, Informationsverarbeitung und Ergonomie FKIE, Kognitive Mobile Systeme, Wachtberg, 6DSLAM (6D Simultaneous localization and mapping) — Janusz Będkowski, Ph.D. (IPPT PAN); Julius-Maximilians-Universität Würzburg, Am Hubland D-97074 Würzburg, Germany, Pattern recognition for security application — Janusz Będkowski, Ph.D. (IPPT PAN); University of Erlangen-Nuremberg, Institute of Biomaterials Magnesium based composites for biomedical applications — Assoc. Prof. Michał Basista (IPPT PAN)

**GREECE**, Assoc. Prof. Nikolaos Pnevmatikos, Technological Educational Institute of Athens, Structural health monitoring of bolted connections — Bartłomiej Błachowski, Ph.D. (IPPT PAN); Prof. Ph. Komninou, Prof. T. Karakostas, Prof. G. Dimitrakopoulos, Prof. J. Kioseoglou, A. Lotsari, Ph.D, School of Physics, Faculty of Sciences at Aristotle University of Thessaloniki, Modelling of coupled fields in III-nitride hetero-structures, piezoelectric properties of semipolar and nonpolar III-nitride semiconducting heterostructures — Prof. Paweł Dłużewski, Grzegorz Jurczak, Ph.D. T. Young, Ph.D. (IPPT PAN);

**GREAT BRITAIN**, Prof. Georges Limbert, University of Southampton, Large-deformation contact modelling of human skin, including geometric and mechanical inhomogeneities at the micro-scale — Jakub Lengiewicz, Ph.D. (IPPT PAN);



Fig. 10.8. Prof. T.A. Kowalewski (IPPT PAN), chairman of the Scientific Committee of XXII Fluid Mechanics Conference with invited honorary speaker, Prof. Keith Moffat (Cambridge, UK), September 2016

**IRAN**, Polymer Engineering Group, Department of Chemical Engineering, University of Technology, Isfahan, Polymer/ceramic bio-nanocomposites formed by electrospinning — Prof. Paweł Sajkiewicz (IPPT PAN);

**ISRAEL**, Technion - Israel Institute of Technology, Haifa, Electrospinning of nanofibers, phase transitions in polymeric nanofibers — Prof. Paweł Sajkiewicz (IPPT PAN);

**ITALY**, Massimiliano Lanzi, Ph.D., Department of Industrial Chemistry, "Toso Montanari", Alma Mater Studiorum, University of Bologna, Electrospinning of conductive polymers — Filippo Pierini, Ph.D. (IPPT PAN); Università Politecnica delle Marche, Ancona (Sezione di Biochimica, Biologia e Fisica) Ancona, Determination of thermal residual stresses in metal-ceramic bulk composites by neutron diffraction — Assoc. Prof. Michał Basista (IPPT PAN); Prof. Tommaso Ruggeri Department of

Mathematics and Alma Mater Research Centre on Applied Mathematics, University of Bologna, Hyperbolic systems of partial differential equations and wave propagation — Prof. Wiesław Larecki (IPPT PAN); University of Trento, Prof. Davide Bigoni, Modelling of elastoplastic coupling in granular materials. Bifurcation of elastic solids with sliding interfaces — Prof. Stanisław Stupkiewicz (IPPT PAN); University of Palermo, Prof. Giuseppe Giambanco, dr Mohsen Rezaee Hajidehi, Modelling of strain localization and Lüders bands in shape memory alloys — Prof. Stanisław Stupkiewicz (IPPT PAN);



Fig. 10.9. Pictured from right to left are: Prof. Marco Paggi (IMT School for Advanced Studies Lucca, ITALY), Prof. Jean-Francois Molinari (École Polytechnique Fédérale de Lausanne (EPFL), SWITZERLAND) and Prof. Stanisław Stupkiewicz (IPPT PAN)



Fig. 10.10. Prof. Stanisław Stupkiewicz (pictured first from right), at the Micro/Nanoscale Models for Tribology ( $\mu/n$ -Tribo-Models) workshop at the Lorentz Centre@Oort, Leiden, Netherlands, February, 2017



Fig. 10.11. View of the scissor-type bridge prepared to perform dynamic research carried out in cooperation with IPPT, Fuji, JAPAN

**JAPAN**, AICHI Institute of Technology, Toyota, Prof. H. Tobushi, Prof. R. Matsui, Dr K. Takeda, Shape Memory Materials — Prof. Elżbieta Pieczyska (IPPT PAN); University of Hiroshima, Analysis of nonlinear multifolding structures. Design and optimization of scissor-type mobile bridges — Piotr Pawłowski, Ph.D., Cezary Graczykowski, Ph.D., Prof. Jan Holnicki-Szulc (IPPT PAN);

**LITHUANIA**, Department of Mechanical Engineering, Kaunas University of Technology, Kaunas, Prof. Paulius Griškevičius, Smart composite materials — Assoc. Prof. Łukasz Jankowski, Anita Orłowska, Ph.D. (IPPT PAN);

**LUXEMBOURG**, Prof. Stephan Bordas, University of Luxembourg, Optimization of distributed reconfiguration planning algorithms for Programmable Matter — Jakub Lengiewicz, Ph.D. (IPPT PAN);

**NETHERLANDS**, Volkert van Steijn, Ph.D., Delft University of Technology, Droplet formation in the microfluidic T-junction — Assoc. Prof. Piotr Korczyk (IPPT PAN);

Fig. 10.12. Meeting in the NORUT Northern Research Institute, TROMSO, NORWAY, 18th September, 2017 with Director, Dr Rune Storvold (IPPT representatives: Zbigniew Wolejsza, Ph.D., D.Sc., Krzysztof Kaźmierczak Ph.D., Rami Faraj)



**NORWAY**, Northern Research Institute, NORUT, Tromso, Norway, Dr Rune Storvold, Monitoring of arctic areas — Prof. Jan Holnicki-Szulc, Zbigniew Wolejsza, Ph.D., D.Sc. (IPPT PAN);

**ROMANIA**, Mariana Cristea, Dynamic Mechanical Analysis (DMA) of Polyurethane Shape Memory Polymers (SMP) — Assoc. Prof. Elżbieta Pieczyska, Maria Staszczak, Karol Golasiński (IPPT PAN); Technical University of Cluj-Napoca, Experimental and numerical investigation of sheet metal forming — Prof. Jerzy Rojek (IPPT PAN);

**SLOVAKIA**, Institute of Materials Research of Slovak Academy of Science, Kosice, Micro-CT examination of composite microstructure — Assoc. Prof. Michal Basista (IPPT PAN); Institute of Measurement Science of the Slovak Academy of Sciences, Bratislava, Microstructure and thermal residual stress effect on fracture properties of metal matrix composites — Assoc. Prof. Michal Basista (IPPT PAN);

**SLOVENIA**, University of Ljubljana, Prof. Joze Korelc, Automation and efficient computational algorithms for the modelling of materials and contact interfaces — Prof. Stanisław Stupkiewicz (IPPT PAN);

**SPAIN**, University Carlos III of Madrid, Department of Continuum Mechanics and Structural Analysis, Prof. J. Fernandez-Martinez, Prof. Guadalupe Vadillo, The role of anisotropy in material failure — Assoc. Prof. Katarzyna Kowalczyk-Gajewska (IPPT PAN); International Centre for Numerical Methods in Engineering (CIMNE), Barcelona, Prof. Eugenio Oñate, Modelling of rock cutting using the discrete element method — Prof. Jerzy Rojek (IPPT PAN); Miguel Hernandez University, Alicante, IDIBAPS Barcelona, Transmission of information between cortical neurons — Prof. Janusz Szczepański, Prof. Eligiusz Wajnryb (IPPT PAN); Prof. Maria Victoria Sanchez-Vives, August Pi i Sunyer Biomed Res Inst IDIBAPS, Syst Neuroscience, Barcelona, Neuronal signals analysis (cortical networks) with the application of information theory — Prof. Janusz Szczepański (IPPT PAN);



**Fig. 10.13.** Assoc. Prof. Katarzyna Kowalczyk-Gajewska with participants QUATIFY project from the University Carlos III of Madrid, SPAIN (from right: Prof. Guadalupe Vadillo and Prof. José Rodríguez-Martínez)

**TURKEY**, Bilkent University, Modelling of elastohydrodynamic lubrication in soft contacts — Prof. Stanisław Stupkiewicz (IPPT PAN);

**USA**, Department of Mathematics and Statistics, Oakland University, Rochester, MI, Prof. Meir Shillor, Dynamics of nonlinear elastic structures under moving inertial loads — Prof. Czesław Bajer, Assoc. Prof. Bartłomiej Dyniewicz (IPPT PAN); Materials Science and Engineering Dept., Clemson University, Clemson, S.C., Hot pressing

of ceramic and ceramic/metal composite membranes — Assoc. Prof. Michal Basista (IPPT PAN); Prof. Juan Caicedo, University of South Carolina, Human-structure interaction — Bartłomiej Błachowski, Ph.D. (IPPT PAN); Prof. Billie F. Spencer, Jr. University of Illinois at Urbana - Champaign, Structural health monitoring of truss structures — Bartłomiej Błachowski, Ph.D. (IPPT PAN); Prof. Howard A. Stone, Dr. Steve Kuei, Princeton University, Princeton, Modes of the dynamics of flexible fibers on shear flow — Prof. Maria Ekiel-Jeżewska, Agnieszka Słowicka, Ph.D. (IPPT PAN); Purdue University, Durability of cement based composites in aggressive environment - application of experimental and soft computing methods — Prof. Michał A. Glinicki (IPPT PAN); Prof. Alexander Yarin, University of Illinois at Chicago Mechanical and Industrial Engineering Department, Electrospinning of nanofibres, biomedical applications — Prof. Tomasz A. Kowalewski (IPPT PAN);



**Fig. 10.15.** SeaBASS marine bioacoustics workshop organised by the PennState University in Leesburg n/Washington, USA. Pictured left to right: Susan Parks (Penn State), Jeremy Young (University of Hawaii), Łukasz Nowak (IPPT PAN) at the joint measurement data analysis



**Fig. 10.14.** The cover of a new, joint publication by Prof. Jan Sławianowski (IPPT PAN), Prof. Frank E. Schroeck Jr. (Department of Mathematics, University of Denver, USA) and Agnieszka Martens (IPPT PAN)

Los Alamos National Laboratory, William S. Hlavacek, Ph.D., Software for simulation of biochemical process on the plasma membrane at the single-molecule resolution — Prof. Tomasz Lipniacki, Marek Kocharczyk (IPPT PAN); New Jersey Institute of Technology, Prof. Ali Abdi, Information-theoretic approach to the analysis of cell signaling networks — Prof. Tomasz Lipniacki (IPPT PAN); University of California, Davis, John Albeck, Ph.D., Model-based analysis of relaxation oscillations in the MAPK signaling pathway — Prof. Tomasz Lipniacki, Marek Kocharczyk, Paweł Kocieniewski, Joanna Jaruszewicz, Ph.D. (IPPT PAN); University of New Mexico, Albuquerque, Prof. Aleksander Zubelewicz, Development of new formulation



**Fig. 10.16.** Meeting at the Conference Banquet, The International Workshop on Advances in Shape Memory Materials, March 27, 2017, Nagoya  
From right: Prof. Hisaki Tobushi from AICHI Institute of Technology, Toyota, Japan, Prof. Elżbieta Pieczyska (IPPT PAN), Prof. Qingping Sun from the Hong Kong University of Science and Technology (HKUST), School of Engineering



**Fig. 10.18.** French-Polish research group collaborating in the broad field of mechanics and its various applications during the 25th French-Polish Seminar of Mechanics, Bourges, France, 2017. Pictured from right to left: Bartłomiej Dyniewicz, Ph.D., Prof. Jerzy Bajkowski, Warsaw Univ. of Technology, Prof. Mircea Sofonea, Director of the Laboratoire de Mathématiques et Physique, Université de Perpignan Via Domitia, France

of the discrete element method — Prof. Jerzy Rojek (IPPT PAN); Prof. Krzysztof Kuczera, Prof. Gouri S. Jas, Dr. Eric C. Rentchler, Carey K. Johnson, C. Russel Middaugh, University of Kansas, Lawrence and Dr. J. R. Hermansen, School of Medicine, Central University of the Caribbean, Bayamon, Reorientation Motion and Preferential Interactions of a Peptide in Denaturants and Osmolyte — Agnieszka Słowicka, Ph.D. (IPPT PAN); Prof. Ehud Kaplan, The Icahn School of Medicine at Mount Sinai NY, USA, Signals processing analysis (LGN) with application of Information Theory — Prof. Janusz Szczepański, Agnieszka Pręgoska, Ph.D. (IPPT PAN);



**Fig. 10.17.** Pictured left to right: Prof. Mahdi Taiebat, Univ. of British Columbia, Canada, Prof. Yannis F. Dafalias, Univ. of California, USA, National Univ. of Athens, Grecja, Prof. Zenon Mróz, IPPT, Prof. Majid T. Manzari, George Washington Univ., USA, ASCE 2016 EMI International Conference, October 25-27, Metz, France



Fig. 10.19. Visit at the laboratory of Advanced Composite Materials, IPPT PAN (presentation of Assoc. Prof. Michał Basista)

Fig. 10.20. (right) Visit at the laboratory of Surface Layers, IPPT PAN (presentation of Dariusz Jarząbek, Ph.D.)



Figs 10.19-20. Visit of Helen Chrąy-Head of the Unit of Advanced Materials and Nanotechnologies of the European Commission, Directorate-General for Research and Innovation at IPPT PAN, 14<sup>th</sup> September 2017



Fig. 10.21. Visit of Prof. Robertas Balevicius at IPPT PAN. Pictured from left to right are: Prof. Marek Janas, Prof. Henryk Petryk, Prof. Zenon Mróz from IPPT PAN and Prof. Robertas Balevicius, Vilnius University of Technology (IPPT cooperation as part of the programme between the Academies of Sciences of Poland and Lithuania)



Fig. 10.22. The Polish-Japanese (IPPT the Hiroshima University and CMI Institute on Fuji) research group conducting dynamic research on the scissor-type bridge on Fiji. The IPPT PAN representatives were: Piotr Pawłowski, Ph.D., Cezary Graczykowski, Ph.D.



Fig. 10.23. Collaboration of IPPT PAN and AIT, Toyota-city, Japan - International Seminar of JSME on Shape Memory Materials, organised by H. Tobushi. Pictured here is Assoc. Prof. E. Pieczyska and M. Staszczak (centre, back row)



Fig. 10.24. QUANTIFY project participants (in the frame of the H2020-MSCA-RISE-2017 call) in a meeting in Israel. The QUANTIFY project is coordinated by the University Carlos III of Madrid (and led by Prof. Jose. A. Rodriguez-Martinez). The IPPT PAN representative is Assoc. Prof. Katarzyna Kowalczyk-Gajewska

### EUROPEAN VIRTUAL INSTITUTE ON KNOWLEDGE-BASED MULTIFUNCTIONAL MATERIALS (KMM-VIN AISBL)

KMM-VIN AISBL founded in 2007 is a non-profit international association based in Brussels with the KMM-VIN Branch Poland in Warsaw, which fosters integrated basic and applied research, educational and innovation activities in the field of advanced structural and functional materials. The main activities and services are dedicated to Transport, Energy and Health sectors. The KMM-VIN research activities are conducted within four Working Groups: 1. Materials for Transport, 2. Materials for Energy, 3. Biomaterials and 4. Modelling and one emerging group on Graphene/2D materials. The KMM-VIN AISBL consists of 70 members including academic and industrial organisations and individual experts from 16 EU Member States with knowledge and skills in materials processing, characterisation, testing and modelling. The KMM-VIN has emerged from the FP6 Network of Excellence KMM-NoE project ("Knowledge-based Multicomponent Materials for Durable and Safe Performance", 2004-2009) coordinated by the IPPT PAN, which was devoted to the study, understanding, design and development of new advanced materials (ceramic, metallic, metal-ceramic,



**Fig. 10.19.** The coordinators of KMM-VIN Working Groups (from left to right): Peter Hansen (Graphene/2D Materials), Pedro Egizabal (Materials for Transport), Aldo R. Boccaccini (Biomaterials), Monica Ferraris (Materials for Energy) and Michał Basista (Chief Executive Officer)

intermetallic, polymer, etc). Besides joint research activities, the KMM-VIN runs mobility programme for young researchers, organizes specialised courses and workshops targeted at industry, manages own database on KMM-VIN materials and members' expertise and research infrastructure. The KMM-VIN dissemination activities are being done through the association website with public and members' areas and through the KMM-VIN Newsletter published twice a year.



**Fig. 10.20.** KMM-VIN 7th Industrial Workshop on "Biomaterials: Key Technologies for Better Health-care", 27-28 September 2017, Erlangen, Germany

## 11. CONFERENCES ORGANISED AND CO-ORGANISED BY IPPT PAN IN 2016-2017

### SELECTED SCIENTIFIC CONFERENCES:

- Microsymposium on Electrospinning for Biomedical Applications, April 29, 2016, Warsaw, Poland
- Interaction of Applied Mathematics and Mechanics Conference, May 9-11, 2017, PARIS
- 8th Contact Mechanics International Symposium, CMIS 2016, May 11-13, 2016, Warsaw, Poland
- ECCOMAS International Conference IPM 2017 on Inverse Problems in Mechanics of Structure and Materials, May 31 - June 2, 2017, Rzeszów, Kraszczyn, Poland
- XL Solid Mechanics Conference, SolMech 2016, August 29 - September 2, 2016, Warsaw, Poland
- 6th Scientific & Technological Conference Diagnostics Of Materials And Industrial Components, June 29 - July 1, 2017, Gdansk University Of Technology, Gdańsk, Poland
- XXII Fluid Mechanics Conference, KKMP2016, September 11-14, 2016, Słok near Bełchatów, Poland
- 5th Conference on Nano- and Micromechanics, July 4-6, 2017, Wrocław, Poland
- "CePT - Platform for innovative medicine development" conference, February 27, 2017, Warsaw, Poland
- 22nd International Conference on Computer Methods in Mechanics, September 13-16, 2017, Lublin, Poland
- International Workshop on Advances in Shape Memory Materials, March 27-29, 2017, Nagoya, Japan
- Workshops for Engineers and Scientists "Experimental Mechanics of Materials and Structural Elements" - MechMAT, October 12, 2017, Warsaw, Poland
- Composites and Ceramic Materials Technology, Application and Testing, 15th International Conference under auspices of European Materials Research Society, E-MRS, May 10-13, 2017, Białowieża, Poland
- Experiments in Fluid Mechanics, October 23-24, 2017, Warsaw, Poland

More details on conferences organised and coorganised by IPPT PAN are available on the IPPT website: [www.ippt.pan.pl](http://www.ippt.pan.pl), see tab: Scientific Activity

## THE 40<sup>TH</sup> SOLID MECHANICS CONFERENCE, 2016

A long tradition to organise the Solid Mechanics Conferences (SolMech) at different locations in Poland aims to include all areas and research centres in Poland focused on mechanics of materials and structures including interactive fields. The Polish Solid Mechanics Conferences have been organised by IPPT PAN since 1953, when the first conference was held in Karpacz located in the south of Poland. The chairman of Polish Solid Mechanics Conferences since its inception in the year 1953 until 1970 was Prof. Waław Olszak (1902–1980).

He was also one of the co-founders of the Institute of Fundamental Technological Research of the Polish Academy of Sciences in 1952. Therefore, he was chosen as a patron of the 40th Solid Mechanics Conference. At the beginning, the conferences mainly had a national character and concentrated mostly on problems of elasticity, plasticity and structural mechanics. Later on, they became international with considerable participation of scientists from foreign countries, and with a much wider scope covering most important and actual aspects of solid mechanics. The Conferences have maintained high scientific standard and serve as a forum for the exchange of ideas and research information. Their official language is English.



Fig. 11.1. Prof. W. Olszak – Co-founder of IPPT and chairman of Polish Solid Mechanics Conferences in the years 1953-1970

The 40th Solid Mechanics Conference (SolMech 2016), chaired by Prof. Ryszard Pęcherski, took place on August 29 - September 2, 2016, in Warsaw and gathered 236 participants: 86 from abroad and 150 from Poland.

The program of the Conference included 9 thematic sessions, 7 invited plenary lectures and 18 keynote lectures. Among the thematic sessions, a special session entitled "Elasticity, Plasticity and Phase Transition" was organized in memory of Professor Bogdan Raniecki. It is also noteworthy to mention that the special session entitled "Geomechanics and Multiscale Modelling of Materials" was devoted to the anniversary of Professor Zenon Mróz, who also acted as the Honorary Chairman



Fig. 11.2. Opening speech by Prof. Ryszard Pęcherski - Chairman of SolMech 2016

Pictured from left to right are: Prof. Henryk Petryk, Prof. Tadeusz Burczyński, Prof. Ryszard Pęcherski, Prof. Zenon Mróz



Fig. 11.3. Participants of the 40<sup>th</sup> Solid Mechanics Conference, 2016, Warsaw, Poland

More details on SolMech 2016 are available on the conference website: <http://solmech2016.ippt.pan.pl>

of the Conference. Plenary lectures were delivered by the distinguished Professors: Davide Bigoni (Italy), Alexis Rusinek (France), Ignacio Romero (Spain), Zdenek Bazant (USA), Werner Wagner (Germany), Tomasz Lewiński and Katarzyna Kowalczyk-Gajewska (Poland). The programme of the conference, including information about all thematic sessions, invited plenary lectures, keynote lectures and contributed papers, together with all abstracts, is available on the conference website: <http://solmech2016.ippt.pan.pl/>. The members of the Scientific Committee, International Advisory Board and Organising Committee are also listed on the conference website.

## THE CMIS, 2016

The series of CMIS symposia started in 1992 in Lausanne, with the 7th CMIS held in Abu Dhabi in 2014. Following the tradition, the aim of the CMIS 2016 symposium was to gather researchers from the mathematical and engineering communities working on various aspects of contact mechanics using theoretical, experimental and computational approaches.

The 8th CMIS symposium, chaired by Prof. Stanisław Stupkiewicz, took place at IPPT PAN, in Warsaw, Poland on May 11-13, 2016.



Fig. 11.4. Participants of the 8th Contact Mechanics International Symposium, CMIS 2016, May 11-13, 2016, IPPT PAN

## THE MICROSYMPOSIUM ON ELECTROSPINNING FOR BIOMEDICAL APPLICATIONS, 2016

The Microsymposium took place on April 29, 2016 at IPPT PAN. Out of about 40 participants from various institutions, 9 speakers presented their research topics. Our special guest, Prof. Eyal Zussman from Technion - Israel Institute of Technology, Haifa, Israel, presented a very interesting and inspiring topic concerning stimuli-responsive polymers.



Fig. 11.5. From left: Prof. Paweł Sajkiewicz (IPPT PAN), Prof. Eyal Zussman, Haifa, Israel, Arkadiusz Gradys, Ph.D. (IPPT PAN)

IPPT PAN - Technion Microsymposium on Electrospinning for Biomedical Applications, April, 29, 2016, Warsaw, Poland

## THE IAMMC, 2017

"Interaction of Applied Mathematics and Mechanics Conference" (IAMMC2017) was the French-Polish conference devoted to selected problems of applied mathematics and mechanics and the relation between them. IAMMC 2017 was under the charge of the Committee on Mechanics of the Polish Academy of Sciences and IPPT PAN.

IAMMC 2017 was a special occasion to celebrate the 60<sup>th</sup> anniversary of signing the agreement about cooperation between the Polish Academy of Sciences and the Centre National de la Recherche Scientifique (CNRS).



Fig. 11.6. Meeting at the Embassy of the Republic of Poland in Paris

From right: Prof. Tadeusz Burczyński - Director of IPPT PAN, Prof. Marek Więckowski - Director of the Scientific Centre of the Polish Academy of Sciences in Paris, Prof. Elżbieta Frąckowiak - Vice-President of the Polish Academy of Sciences, Prof. François Béguin from the Poznań University of Technology, Prof. Henryk Petryk (IPPT PAN) and Prof. Jerzy Rojek (IPPT PAN)



Fig. 11.7. Opening speech by Prof. Elżbieta Frąckowiak - Vice-President of Polish Academy of Sciences

On the right: Prof. Tadeusz Burczyński - Director of IPPT PAN



Fig. 11.8. Participants of IAMMC 2017, May, 9-11, 2017, Paris  
More: <http://iammc2017.ippt.pan.pl/>

## THE 15TH INTERNATIONAL CONFERENCE COMPOSITES AND CERAMIC MATERIALS TECHNOLOGY, APPLICATION AND TESTING, 2017

The Conference has a training profile and is organized under auspices of the European Materials Research Society (E-MRS). It has been held every two years, since 1991. The Conference series is dedicated to technology, research and the application of modern ceramic materials. The Conference used to be promoted and organised by Prof. Jerzy Ranachowski (1926-2000), late professor of IPPT PAN.



Fig. 11.9. Participants of the Composites and Ceramic Materials Technology, Application and Testing, 15th International Conference under auspices of European Materials Research Society, E-MRS, May, 10-13, 2017, Białowieża, Poland

## "CEPT - PLATFORM FOR INNOVATIVE MEDICINE DEVELOPMENT" CONFERENCE, 2017

The Conference took place on February 27, 2017. Researchers of the Laboratory of Polymers and Biomaterials, also present at the conference, presented the idea of electrospun materials for biomedical applications. Researchers from the Laboratory of Professional Electronics IPPT PAN presented two ultrasound systems. The first one, uScan2, was a high-frequency medical ultrasound scanner for applications in dermatology. The second one, mUSG, was a low-cost research scanner for research and educational purposes.



Fig. 11.10. Prof. Sajkiewicz and the team from the Laboratory of Polymers and Biomaterials talking to a guest at the exhibition stand



Fig. 11.11. Presentation of the team from the Laboratory of Professional Electronics



## OTHER SELECTED EVENTS

### THE TELEMEDICINE AND E-HEALTH 2017" CONFERENCE



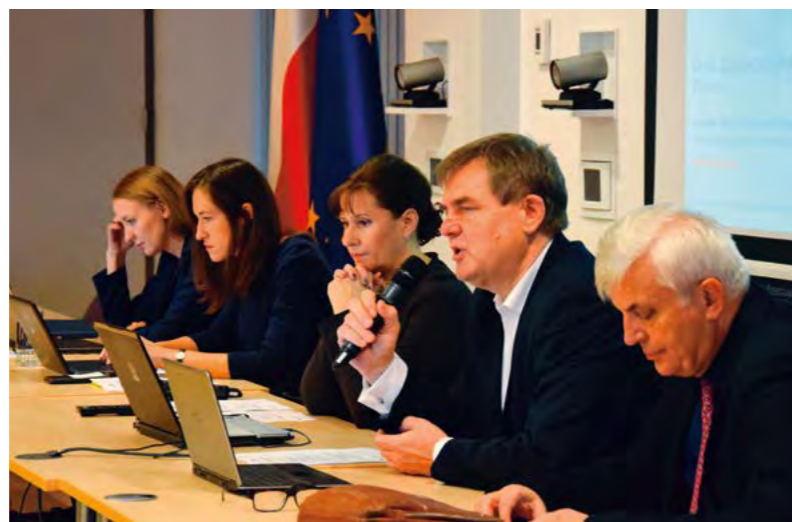
Fig. 11.12. The award ceremony during the "Telemedicine and e-Health 2017" conference (IPPT PAN, September 8, 2017). Photo: R. Czeladko/NCP.

The Conference is organized by the Polish Telemedicine and e-Health Society. Co-organizers are Polish National Contact Point (NCP), IPPT PAN, and Department of Medical Informatics and Telemedicine at Medical University of Warsaw

### THE 4<sup>TH</sup> MEETING OF THE POLISH NCP NETWORK, BRUSSELS

Fig. 11.13. The 4<sup>th</sup> Meeting of the Polish NCP Network, held in Brussels on the 21<sup>st</sup> November, 2017. The meeting was organised by the Polish NCP in cooperation with the Ministry of Science and Higher Education and the Permanent Representation of the Republic of Poland to the European Union. Photo: R. Czeladko/NCP

From right: Prof. Tadeusz Burczyński - Director of IPPT PAN, Zygmunt Krasieński, Ph.D. - Director of the Polish NCP



### THE "CRYSTAL BRUSSELS PRIZE" CEREMONY



Fig. 11.14. The award gala and the Crystal Brussels Prize. The Prize is awarded to Polish institutions, scientists and entrepreneurs for their achievements in research and innovation programmes of the European Union. Photo: NCP

The idea for the prize was born in the NCP. Pictured left to right are: Prof. Tadeusz Burczyński - Director of IPPT PAN and Andrzej Siemaszko, Ph.D. (IPPT PAN /NCP)

# 12. PROMOTIONS AND IMPROVEMENT OF SCIENTIFIC QUALIFICATIONS

## PROFESSOR TITLES AWARDED BY THE PRESIDENT OF THE REPUBLIC OF POLAND

### 1. Paweł Łukasz Sajkiewicz, (Professor since December 2, 2016)



Fig. 12.1. Prof. Paweł Ł. Sajkiewicz's nomination during the official celebration at the Presidential Palace in Warsaw. Photo from the President's Office (K. Sitkowski)

By the decision of December 2, 2016, the President of the Republic of Poland Andrzej Duda granted the title of professor to Mr Paweł Łukasz Sajkiewicz, Ph.D., D.Sc.

**Prof. Paweł Łukasz Sajkiewicz** is an expert in the field of polymer physics, structure and phase transitions of polymers, biopolymers, and tissue engineering with particular interest in biodegradable polymer scaffolds for regenerative medicine. Graduated from the Faculty of Materials Science at the Warsaw University of Technology, PhD and habilitation obtained at IPPT (1989 and 2005, respectively), Postdoctoral Research Associate at the University of Tennessee, Materials Science and Engineering Department, Knoxville, Tennessee, USA. Awarded for scientific and professional achievements

by the Secretary of the Polish Academy of Sciences and Director of the IPPT PAN. Author of more than 60 scientific publications and 3 patents. Participant in more than 40 international and national conferences, invited lecturer in Japan, Italy, USA, and Poland.

Currently, Prof. Paweł Sajkiewicz is the head of the Laboratory of Polymers and Biomaterials of IPPT PAN.

The nomination was held at the Presidential Palace in Warsaw, on January 11, 2017.

## 2. Jerzy Rojek, (Professor since September 23, 2017)



Fig. 12.2. The ceremony of nomination of Prof. Jerzy Rojek the Presidential Palace in Warsaw. Photo from the President's Office (K. Sitkowski)

By the decision of September 23<sup>th</sup> 2017, the President of the Republic of Poland Andrzej Duda granted the title of professor to Mr Jerzy Rojek, Ph.D., D.Sc. from the Department of Information and Computational Science.

**Prof. Jerzy Rojek** is an expert in mechanics, especially in numerical methods for analysis of nonlinear problems in mechanics of continuous and discrete media. In 1985 he graduated from the Faculty of Power and Aeronautical Engineering of the Warsaw University of Technology, he received his PhD in 1993 and habilitation in 2008 at IPPT PAN.

In 1993-1996 he was a postdoctoral researcher at the International Centre for Numerical Methods in Engineering (CIMNE) in Barcelona, in 2009-2012 a visiting professor at the Graz University of Technology. Employed at IPPT since 1996, at present he is the head of the Division of Computational Methods in Nonlinear Mechanics in the Department of Information and Computational Science. Since 2014, has held the position of Deputy Chairman of the Scientific Council of the Institute of Fundamental Technological Research, Polish Academy of Sciences.

His main scientific interests comprise new formulations of the finite and discrete element methods and their application to modelling of materials at various scales, contact mechanics, structural dynamics and coupled problems. Practical applications of developed models and computer programs include powder metallurgy, sheet metal forming and geomechanics. Prof. Rojek has been a principal investigator and coordinator of several national and international research projects.

Supervisor of two PhD theses (at IPPT PAN and UPC-BarcelonaTech). Author of around 150 peer-reviewed articles, including over 30 in journals listed at the JCR. Member of editorial boards of two international journals, member of scientific committees of many international conferences. Member of the Committee on Mechanics of the Polish Academy of Sciences in 2011-2014 and 2015-2018. In 2017 elected President of the Managing Board of the Polish Association for Computational Mechanics.

## HABILITATIONS

### HABILITATIONS OF THE INSTITUTE'S EMPLOYEES AWARDED BY IPPT PAN – YEAR 2016

#### 1. Tomasz G. Zieliński, IPPT PAN

Propagation and attenuation of acoustic waves in porous media with respect to geometric features and vibrations of microstructure  
Discipline: **Mechanics**

#### 2. Jacek J. Hoffman, IPPT PAN

The experimental study of the ablation of graphite by a nanosecond laser pulse  
Discipline: **Mechanics**



Fig. 12.3. Prof. Henryk Petryk, Chairman of the Scientific Council of IPPT PAN, giving the opening speech during the Ceremonial Promotion of Doctors and Postdoctoral Degrees at IPPT PAN, June 5, 2017.

At the presidium table is Prof. Tadeusz Burczyński - Director of IPPT PAN

### OTHER HABILITATIONS AWARDED BY IPPT PAN – YEAR 2016

#### 1. Łukasz Figiel, The University of Warwick, Great Britain

Investigation into the processing-morphology-mechanical behaviour relationship in polymer nanocomposites: modelling and experiments  
Discipline: **Material Engineering**

#### 2. Wojciech Moćko, The Motor Transport Institute

Application of the Hopkinson bar methodology in analysis of the influence of prior fatigue loadings on the visco-plastic tensile characteristics of steels and alloys  
Discipline: **Mechanics**

#### 3. Łukasz Rauch, The AGH University of Science and Technology

Methodology of multiscale modelling with application of heterogeneous hardware architectures  
Discipline: **Informatics**

#### 4. Paweł J. Matuszyk, The Houston Technology Centre

The application of automatic hp-adaptive finite element method to the modelling of borehole sonic logging measurements  
Discipline: **Mechanics**

## HABILITATIONS OF THE INSTITUTE'S EMPLOYEES AWARDED BY IPPT PAN – YEAR 2017

### 1. Piotr Korczyk, IPPT PAN

Droplets as chemical reactors in passive microfluidic systems – mechanical aspects

Discipline: **Mechanics**

### 2. Bartłomiej Dyniewicz, IPPT PAN

Adaptive vibration damping of selected structures using nonclassical materials

Discipline: **Mechanics**

### 3. Tomasz P. Mościcki, IPPT PAN

Numerical modelling of processes occurring during ablation with nanosecond laser pulse

Discipline: **Mechanics**



**Fig. 12.4.** Tomasz P. Mościcki (pictured left) and Jacek J. Hoffman (pictured right) holding diplomas certifying the conferment of the doctor habilitated academic degree. In the middle – Justyna Chrzanowska-Giżyńska, the laureate of the Director of IPPT PAN Award in under 35 age category



**Fig. 12.5.** Tomasz G. Zieliński, giving his speech on behalf of all doctors habilitated and doctors. Next to him stands Prof. Elżbieta Frąckowiak, Vice-President of PAN. Ceremonial Promotion of Doctors and Postdoctoral Degrees at IPPT PAN, June 23, 2016

## OTHER HABILITATIONS AWARDED BY IPPT PAN – YEAR 2017

### 1. Leszek Piotrowski, The Gdańsk University of Technology

The diagnostics of construction materials state with the help of magnetoelastic phenomena

Discipline: **Material Engineering**

### 2. Sławomir Jakiela, The Warsaw University of Life Sciences - SGGW

Mechanics of two-phase flows in advanced biological and chemical laboratories in microscale

Discipline: **Mechanics**

## PH.D. DEGREES

### PH.D. DEGREES OF THE INSTITUTE'S EMPLOYEES AWARDED BY IPPT PAN – YEAR 2016

#### 1. Szymon Nosewicz, IPPT PAN

Discrete element modelling of powder metallurgy processes

Discipline: **Material Engineering**. Supervisor: Prof. Jerzy Rojek

#### 2. Rafał Wiszowaty, IPPT PAN

Designing and Investigation of Pneumatic Adaptive Absorbers

Discipline: **Mechanics**. Supervisor: Prof. Jan Holnicki-Szulc

#### 3. Marta Gruca, IPPT PAN

Motion of regular systems of many particles interacting hydrodynamically under gravity

Discipline: **Mechanics**. Supervisor: Prof. Maria Ekiel-Jeżewska



**Fig. 12.6.** The Ceremonial Promotion of Doctors and Postdoctoral Degrees at IPPT PAN, June 23, 2016  
Front row: doctors of Science (left to right): Michał Chromiak, Szymon Nosewicz, Grzegorz Suwała

**Fig. 12.7.** Szymon Nosewicz receives his doctoral diploma and is congratulated by Prof. Elżbieta Frąckowiak, Vice-President of PAN and Prof. Tadeusz Burczyński - Director of IPPT PAN.  
The Ceremonial Promotion of Doctors and Postdoctoral Degrees at IPPT PAN, June 23, 2016



### OTHER PH.D. DEGREES AWARDED BY IPPT PAN – YEAR 2016

#### 1. Michał Chromiak, The Maria Curie Skłodowska University in Lublin

Universal integration architecture for heterogeneous datasources and optimisation methods

Discipline: **Informatics**. Supervisor: Prof. Krzysztof Stencel

### PH.D. DEGREES OF THE INSTITUTE'S EMPLOYEES AWARDED BY IPPT PAN – YEAR 2017

#### 1. Mariusz Dąbrowski, IPPT PAN

Effect of high calcium fly ash on the microstructure and freeze-thaw resistance of cement matrix composites

Discipline: **Material Engineering**. Supervisor: **Prof. Michał Glinicki** and **Assoc. Prof. Daria Józwiak-Niedźwiedzka** (assistant supervisor)

#### 2. Michał J. Byra, IPPT PAN

Breast lesion classification using statistical properties of backscattered ultrasound

Discipline: **Electronics**. Supervisor: **Prof. Andrzej Nowicki** and **Katarzyna Dobruch-Sobczak, Ph.D.** (assistant supervisor)

#### 3. Karol Frydrych, IPPT PAN

Modelling of microstructure evolution of high specific strength metals subjected to severe plastic deformation processes

Discipline: **Mechanics**. Supervisor: **Assoc. Prof. Katarzyna Kowalczyk-Gajewska**

#### 4. Piotr Karwat, IPPT PAN

Numerical reconstruction of acoustic wave velocity field based on the analysis of ultrasonic signals

Discipline: **Electronics**. Supervisor: **Assoc. Prof. Jurij Tasinkiewicz**



**Fig. 12.8.** Stanisław Brodowski from the Jagiellonian University receives his doctoral diploma and is congratulated by Prof. Henryk Petryk, Chairman of the Scientific Council of IPPT PAN

The Ceremonial Promotion of Doctors and Postdoctoral Degrees at IPPT PAN, June 5, 2017



**Fig. 12.9.** Bartłomiej Dyniewicz receives his diploma certifying the conferment of the doctor habilitated academic degree and is congratulated by Prof. Henryk Petryk, Chairman of the Scientific Council of IPPT PAN, 2017

### OTHER PH.D. DEGREES AWARDED BY IPPT PAN – YEAR 2017

#### 1. Adam Strzelecki, The Jagiellonian University

Image reconstruction and simulation of strip Positron Emission Tomography scanner using computational accelerators

Discipline: **Informatics**. Supervisor: **Prof. Piotr Białas**

#### 2. Piotr Łabędź, The Cracow University of Technology

Fractal algorithms in the digital analysis of spatial objects

Discipline: **Informatics**. Supervisor: **Prof. Tadeusz Burczyński**

#### 3. Stanisław Brodowski, The Jagiellonian University

Function approximation learning through hierarchical division to subproblems and combining their solutions

Discipline: **Informatics**. Supervisor: **Assoc. Prof. Andrzej Bielecki**

#### 4. Aneta M. Wróblewska, The Maria Curie Skłodowska University in Lublin

Linguistic dynamic systems based on algebraic graphs and their application to cryptography

Discipline: **Informatics**. Supervisor: **Prof. Vasyl Ustyomenko**

#### 5. Szymon Gajek, The Jagiellonian University

Computer aided conceptual design with the use of graph data structures and logic formulae

Discipline: **Informatics**. Supervisor: **Prof. Ewa Grabska**

#### 6. Adam Marszałek, The Cracow University of Technology

Ordered fuzzy numbers in modelling and simulation of financial time series

Discipline: **Informatics**. Supervisor: **Prof. Tadeusz Burczyński** and **Michał Bereta, Ph.D.** (assistant supervisor)

The Ceremonial Promotion of Doctors and Postdoctoral Degrees and the Awards Ceremony took place at IPPT PAN on June 23, 2016 and June 5, 2017. The ceremonies were presided over by: Prof. Tadeusz Burczyński, Director of IPPT PAN and Prof. Henryk Petryk - Chairman of the IPPT PAN Scientific Council. In 2016, Prof. Elżbieta Frąckowiak, Vice President of PAN, also attended the ceremony.

The ceremonies were held to present doctoral and postdoctoral promotions and the Director of Institute's awards.



**Fig. 12.10.** Hanna Piotrkowska-Wróblewska and Katarzyna Dobruch-Sobczak receive award and is congratulated by Prof. Tadeusz Burczyński - Director of the Institute The Ceremonial Promotion of Doctors and Postdoctoral Degrees at IPPT PAN, June 5, 2017



**Fig. 12.11.** Prof. Czesław Bajer and Bartłomiej Dyniewicz, Ph.D.,D.Sc. receives the Director of Instytute's award and are congratulated by Prof. Tadeusz Burczyński - Director of IPPT PAN and Prof. Elżbieta Frąckowiak, Vice-President of PAN. Ceremonial Promotion of Doctors and Postdoctoral Degrees at IPPT PAN, June 23, 2016



**Fig. 12.12.** Participants of the Ceremonial Promotion of Doctors and Postdoctoral Degrees at IPPT PAN, June 23, 2016



**Fig. 12.13.** Occasional lecture of Prof. Włodzisław Duch during the Ceremonial Promotion at IPPT PAN, June 23, 2016

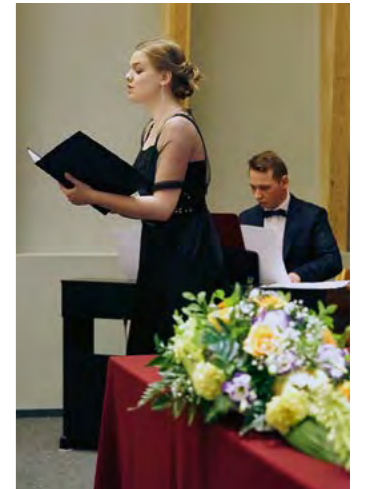


**Fig. 12.14.** Commemorative photo of winners of the Director of IPPT PAN Awards, June 23, 2016



**Fig. 12.15.** Prof. Maria Ekiel-Jeżewska giving her speech on behalf of all winners of the Directors of IPPT PAN Awards, June 5, 2017

**Fig. 12.16. (below)** Participants of the Ceremonial Promotion of Doctors and Postdoctoral Degrees at IPPT PAN. Front row photographed is Prof. Wojciech Maksymowicz from The University of Warmia and Mazury in Olsztyn, who gave an occasional lecture on June 5, 2017



**Fig. 12.17.** The ceremonies were accompanied by concerts of the Fryderyk Chopin University of Music's students - Alicja Krasieńska – soprano, Adrian Gala – piano



**Fig. 12.18.** Commemorative photo of winners of the Director of IPPT PAN Awards, June 5, 2017

# 13. THE DOCTORAL STUDY

The doctoral programme at IPPT PAN was established in 1968 as one of the first among the scientific institutes of the Polish Academy of Sciences. Since then, the IPPT doctoral study unit has played an important role as the Polish third level education, utilising the potential of highly qualified academic staff. Currently, the doctoral programme of the IPPT Doctoral Study is offered in four disciplines: mechanics, electronics, material engineering and computer science. Moreover, in accordance with the proper long-term bi-lateral agreements, the IPPT Doctoral Study performs its activity in cooperation with the doctoral studies of other Polish scientific institutions, i.e. with the Institute of Biocybernetics and Biomedical Engineering of the Polish Academy of Sciences in the field of biomedical engineering as well as with four departments of Polish state universities in the field of computer science. This kind of cooperation has resulted, in 2016-17, in intensive interdisciplinary research that joined experience in the field of material engineering with bioengineering, acoustic diagnostics with medicine, mechanical engineering with computer science and nano-technology, computer science with biology and others.

The doctoral programme at IPPT PAN is largely based on the student's personal research project, which is complemented with courses and clearly specified knowledge requirements. The education process is led by our own scientists, and the lectures given during the successive terms are chosen by the Ph.D. students from among 21 courses included in our own permanent didactic offer as well as from numerous activities conducted in other institutions. Studies must be completed in four years and the Ph.D. degree is awarded on the submission of a thesis subject to its passing a public defense. In addition to fundamental research, since 2017 an applicatory aspect of doctoral studies conducted by IPPT PAN has been significantly emphasized in the form of a participation

in the national educational project titled "Doctorate in implementation". Also, in the framework of this initiative, utilitarian investigations of the Ph.D. students employed in several external non-scientific institutions are supervised by tutors from IPPT PAN.

In 2016-2017, the IPPT Doctoral Study had a total number of 29 Ph.D. students, 20 of whom completed their study in a framework of our scientific activity with a regular scholarship support of IPPT PAN. The remaining 9 students carried out their studies via distance learning using our own highly skilled supervisors and the advanced laboratory equipment. In 2016-2017, 11 scientists achieved the doctoral degree at IPPT PAN, including 7 Ph.D. students of the IPPT Doctoral Study. In 2016, good organization and attractiveness of our doctoral studies led to winning the Second Prize in the "PROPAN" state competition for the most student-friendly doctoral studies in research institutes of the Polish Academy of Sciences.



Fig. 13.1. Prof. Tomasz Szolc received the Second Prize in the "PROPAN" state competition for the most student-friendly doctoral studies in research institutes of the Polish Academy of Sciences (photo: fot. A. Materowicz)

**Head of the Doctoral Study:**  
**Assoc. Prof. Tomasz Szolc**  
**Secretary: Monika Węglowska**  
**Phone: +48 22 826 98 41; 48 22 826 12 81; ext.219**



Fig. 13.2. The Ph.D. students of the IPPT PAN together with Assoc. Prof. Tomasz Szolc – the Head of the Doctoral Study

## LIST OF STUDENTS (AS OF DECEMBER 31, 2017)

### 1<sup>st</sup> year

1. Antolik Aneta
2. Cacko Damian
3. Cegielska Olga
4. Czarnecka Katarzyna
5. Fura Łukasz
6. Gębik-Wrona Maja
7. Jakubiak Marcin
8. Korczak Ilona
9. Kostro Sylwester
10. Musiał Sandra
11. Grigoryan Naira
12. Opiela Kamil
13. Rak Michał
14. Ostrowski Mariusz

### 2<sup>nd</sup> year

1. Fedor Krzysztof
2. Jarosik Piotr
3. Jeznach Oliwia
4. Niemczyk Beata
5. Popławski Błażej
6. Zaremba Damian

### 3<sup>rd</sup> year

1. Faraj Rami
2. Gawlicki Michał
3. Golasiński Karol
4. Marijnissen Michał
5. Madan Nikhil
6. Trombley Chris
7. Wasilewski Maciej
8. Chrzanowska-Giżyńska Justyna

### 4<sup>th</sup> year

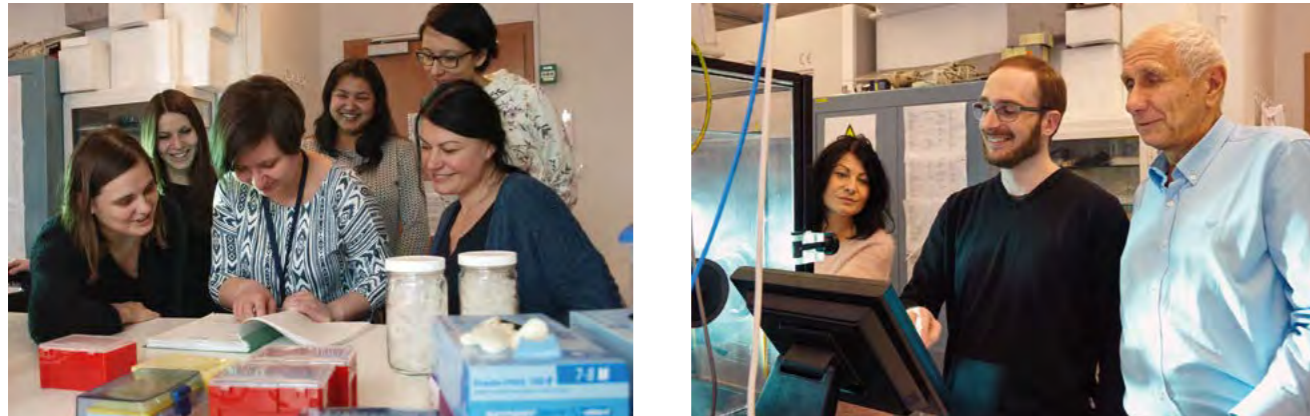
1. Czerwiński Tomasz
2. Gruntowski Andrzej
3. Gruntowski Tomasz
4. Lewandowski Maciej
5. Łazarska Małgorzata
6. Majewski Michał
7. Nienałtowski Karol
8. Nowakowski Kamil
9. Tomaszewska Ewa
10. Wichrowski Michał
11. Witkowski Dawid
12. Żegleń Filip

### 5<sup>th</sup> year

1. Chatterjee Paramita
2. Maj Justyna
3. Staszczak Maria

The teaching process at the IPPT PAN takes place in a student-friendly atmosphere, in cooperation with professors and senior colleagues sharing their knowledge, experience and know-how.

Fig. 13.3. and 13.4. Pictured here is the joint work at the IPPT Laboratory of Bio and Micro Fluidics

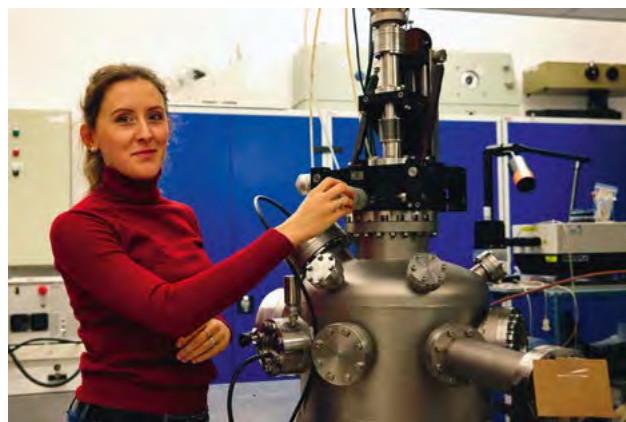


Our doctoral students carry out their research plans with the use of state-of-the-art, specialized equipment.

Fig. 13.5. (right) The photo shows experimental investigation on smart pneumatic systems dedicated to vibration mitigation. Pictured here are: Ph.D. student Rami Faraj and Rafał Wiszowaty, Ph.D. next to an advanced MTS servohydraulic test installation at the IPPT Safety Engineering Laboratory



Fig. 13.6. (below) Justyna Chrzanowska-Giżyńska prepares experimental position for the deposition of superhard thin films. Films are deposited in a vacuum chamber by a nanosecond laser and magnetron



## 14. CONSORTIUMS

The selected consortiums which include the Institute in the years 2016-2017:

### EUROPEAN TECHNOLOGY PLATFORM FOR ADVANCED ENGINEERING MATERIALS AND TECHNOLOGIES (EUMAT)

European Technology Platform for Advanced Engineering Materials and Technologies has been launched in order to assure optimal involvement of industry and other important stakeholders in the process of establishing R&D priorities in the area of advanced engineering materials and technologies. EuMaT should improve coherence in the existing and forthcoming EU projects, in the field of materials R&D.

EuMaT covers all elements of the life cycle of an industrial product, should it be a component, a system or a final product:

- Design, development and qualification of advanced material,
- Advanced production, processing and manufacturing,
- Material and component testing,
- Material selection and optimisation,
- Advanced modelling on all scales,
- Databases and supporting analytical tools,
- Life cycle considerations, including impacts, decommissioning, reliability, hazards, risks and recyclability.

The main goal of EuMaT is to contribute to the best relation and dialogue between industry, R&D actors and institutions aiming at improving the coordination and synergies at national and European level in the field of materials R&D.

### THE CENTRE FOR ADVANCED MATERIALS AND TECHNOLOGIES (CEZAMAT)

The main goal of CEZAMAT is to provide the platform which can integrate research society and enable development of interdisciplinary research on modern materials and technologies. The research infrastructure and integrated research programmes will allow to conduct research and development work at the highest level and to promote and implement new technologies as well. The centre is dedicated to Polish and international scientific communities and companies which use innovative technologies and products.

Another important goal of CEZAMAT is transferring advanced technologies and commercializing developed ideas. The centre's objective is to improve cooperation between Mazovian, national research centres and business. CEZAMAT will also support/help the development of activities in the region.

The consortium members are: the Warsaw University of Technology (coordinator), the Institute of Physical Chemistry of the Polish Academy of Sciences, the Institute of Physics of the Polish Academy of Sciences, IPPT PAN, the Institute of Electronic Materials Technology, the Institute of Electron Technology, the Institute of High Pressure of the Polish Academy of Sciences, the University of Warsaw, and the Military University of Technology.

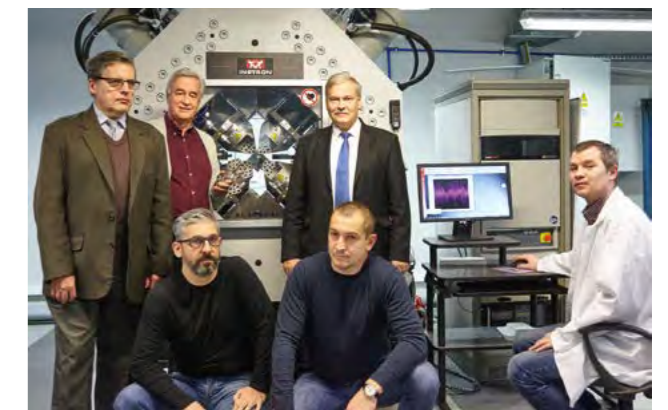


Fig. 14.1. Research team from the Division of Strength of Materials at IPPT with Prof. Zbigniew L. Kowalewski - Head of the Divisions (centre, back row)

## OCHOTA BIOCENTRE CONSORTIUM

Ochota Biocentre is a scientific consortium established on January 1st, 2008 by six institutes located at Ochota Campus in Warsaw. The Ochota Biocentre members are:

- Institute of Biochemistry and Biophysics (IBB PAN)
- Institute of Fundamental and Technological Research (IPPT PAN)
- International Institute of Molecular and Cell Biology (IIMCB)
- Nencki Institute of Experimental Biology (IBD PAN)
- Mossakowski Medical Research Centre (IMDiK PAN)
- Nałęcz Institute of Biocybernetics and Biomedical Engineering (IBIB PAN)

With over 1000 scientists publishing over 350 scientific papers annually, the Ochota Biocentre is one of the largest research centres in Poland.

The main goal of Ochota Biocentre is to consolidate the research potential of its participants who are capable of carrying out extensive research activities in disciplines such as biology, medicine and bioengineering.

All Ochota Biocentre institutes are involved in the implementation of two large projects financed by structural funds: Ochota Biocentre - IT infrastructure for the development of strategic directions in biology and medicine and CePT.

## “AERONET – AVIATION VALLEY”, THE CENTRE OF ADVANCED TECHNOLOGY

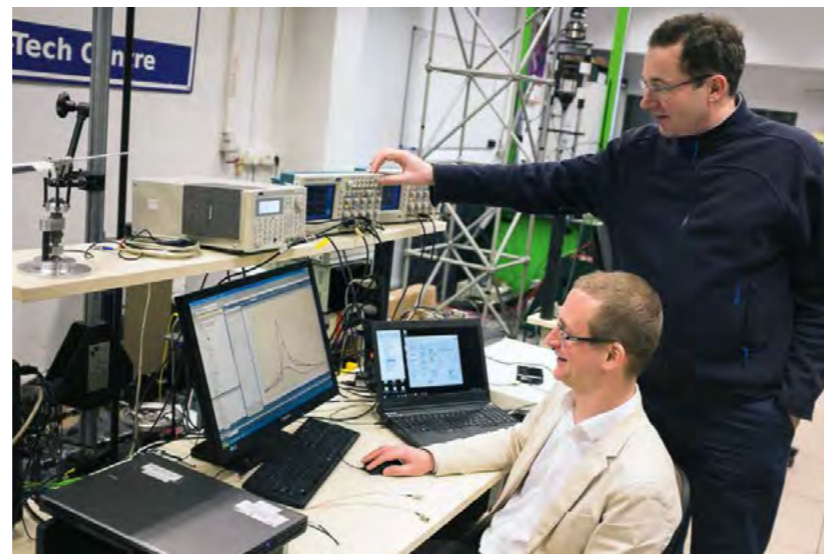
“AERONET – Aviation Valley” Centre of Advanced Technology is a consortium including academic units conducting world-class research and other subjects beneficial to scientific research and developmental work, innovations and implementations within the scope of widely interpreted aviation technology. Undertaking

interdisciplinary activities, the Centre will serve to work out, implement and commercialise new aviation technologies in accordance with the Polish scientific and innovative policy.

Owing to the use of intellectual and research potential of specific creative circles in building and improving the results of activities within the scope of aviation, the Centre will lead to broadening and strengthening the cooperation between universities and industry (research, implementations, etc.) as well as international cooperation.

“AERONET – Aviation Valley” Centre of Advanced Technologies became active in the following scientific fields pertaining to aviation and its related areas:

- Design and testing of aviation structures and propulsions,
- Aviation teleinformatics and avionics systems, Modern materials and surface engineering processes,
- Modern production techniques in the aerospace industry,
- Aerodynamics.



**Fig. 14.2.** Experimental investigation on semi-active systems for structural vibration mitigation dedicated to aeronautical and space applications. Grzegorz Mikułowski, Ph.D. presents results of experiments to Assoc. Prof. Łukasz Jankowski. Scientists working at the laboratory of Safety Engineering, IPPT PAN (ZTI)

## CENTRE FOR PRECLINICAL RESEARCH AND TECHNOLOGY (CEPT)

The CePT consortium was established by: the Medical University of Warsaw (WUM), being the coordinator, the University of Warsaw (UW), the Warsaw University of Technology (PW) and seven institutes of the Polish Academy of Sciences: the Nencki Institute of Experimental Biology (IBD PAN), the Institute of Biochemistry and Biophysics (IBB PAN), the Mossakowski Medical Research Centre (IMDiK PAN), the International Institute of Molecular and Cell Biology (MIBMiK), IPPT PAN, the Institute of High Pressure Physics (IWC PAN), and the Nałęcz Institute of Biocybernetics and Biomedical Engineering (IBIB PAN).



**Fig. 14.3.** The laboratory of Polymers and Biomaterials group presents a stripe of nanofibrous nonwoven material made with the use of electrospinning method



**Fig. 14.4.** Prof. Sajkiewicz and Hanna Piotrkowska-Wróblewska, Ph.D. presents IPPT activities during the “CePT - Platform for innovative medicine development” conference, 2017

The main goal and the chief asset of the CePT consortium is to bring together the potential of outstanding scientists and the opportunities provided by infrastructure of well-equipped state-of-the-art core-facility research laboratories: physical and chemical laboratories (UW), biomolecular and biotechnological facilities (UW, PAN, WUM), biomedical engineering and biomaterial technology laboratories (PW, PAN),

units conducting preclinical research on animal models of diseases associated with the progress of civilisation (PAN, WUM), as well as specialised base for clinical research provided by the Medical University of Warsaw.



# 15. PRESTIGIOUS AWARDS IN 2016-2017

## THE ORDER OF THE WHITE EAGLE



Fig. 15.1. The Order of the White Eagle. Photo from the President's Office (G. Jakubowski)

On May 3, 2016, the President of the Republic of Poland, Andrzej Duda, decorated **Michał Kleiber**, Professor at the IPPT PAN and ordinary member of the Polish Academy of Sciences (PAN), with the Order of the White Eagle.

The Order of the White Eagle (Polish: Order Orła Białego) is Poland's highest decoration awarded both to civilians and the military for their merits. It was officially instituted on November 1, 1705 by Augustus II the Strong and bestowed on eight of his closest, diplomatic and political supporters. It is awarded to the most distinguished Poles and the highest-ranking representatives of foreign countries.



Fig. 15.3. The Order of the White Eagle is attached to a blue ribbon slung over the left shoulder to the right side. The star of the Order, once embroidered, is worn on the left side of the chest

Fig. 15.4. The ceremony in the Royal Castle in Warsaw (from right to left: Michał Lorenc, Prof. Michał Kleiber – IPPT PAN, Irena Kirszenstein-Szewińska, Wanda Póltawska, President Andrzej Duda, Irena Z. Romaszewska, Bronisław Wildstein). Photo from the President's Office (G. Jakubowski)



Fig. 15.2. Prof. Michał Kleiber receives the Order of the White Eagle from the President of the Republic of Poland, Andrzej Duda. Photo from the President's Office (G. Jakubowski)

President Andrzej Duda made the act of decoration. In his speech, he emphasized Professor Michał Kleiber's great merits for science and the Polish economy. The President referred to the remarkable personality of Professor Kleiber as an outstanding scholar, an intellectual and a multi-talented man.

President Andrzej Duda also awarded Irena Szewińska, Michał Lorenc, Wanda Póltawska, Zofia Romaszewska and Bronisław Wildstein. Handing over distinctions, the President thanked them for "their great lives", both from the point of view of the state and service for the Polish people.



## THE TITLE OF DOCTOR HONORIS CAUSA OF THE SILESIAN UNIVERSITY OF TECHNOLOGY

On December 8, 2016 **Prof. Tadeusz Burczyński**, Director of IPPT PAN, was awarded the honorary title of doctor honoris causa of the Silesian University of Technology. The ceremony took place in the Auditorium of the Centre for Educational Congress of the University in Gliwice.



Fig. 15.5. Pictured from left to right are: Prof. Ewa Majchrzak – Director of the Institute of Computational and Mechanical Engineering, the Silesian University of Technology, Prof. Tadeusz Burczyński – the Laureate, Prof. Anna Timofiejczuk, Dean of the Faculty of Mechanical Engineering, the Silesian University of Technology

The ceremony was honored by the presence of many distinguished representatives of the Polish researchers community. Among many congratulation letters received there was also one from the Scientific Council and the employees of IPPT PAN, handed in by Prof. Henryk Petryk.



Fig. 15.7. Prof. Henryk Petryk, Chairman of Scientific Council of IPPT PAN, gives congratulatory speech

The title of doctor honoris causa is an honorary degree conferred by the universities to honour distinguished persons contributing to a specific field of science or culture. Professor Tadeusz Burczyński is a renowned expert in the field of computational mechanics, in particular: the mechanics of materials and structures; sensitivity analysis; inverse problems; stochastic dynamics and fuzzy systems; artificial intelligence and multiscale modelling in engineering. He is also the founder of the research school in the area of boundary element method applications in sensitivity analysis and optimisation. He collaborates with several scientist from prominent universities in Poland and abroad in his interdisciplinary research. He is also a laureate of several other prestigious awards.



Fig. 15.6. The highest academic distinction handed in by the Rector of the Silesian University of Technology – Prof. Arkadiusz Mężyk



Fig. 15.8. Participants of the Ceremony in the Auditorium of the Centre for Educational Congress of the University in Gliwice

# 16. JUBILEE CELEBRATION ON THE 70TH BIRTHDAY OF PROF. MICHAŁ KLEIBER



**Prof. Michał Kleiber** pursues research in theoretical and applied mechanics as well as information science and applied mathematics. The main subject of his research are applications of state-of-the-art computational techniques in different areas of scientific research, technology and medicine – particularly for modelling, analysing, simulating and visualising complex non-linear thermo- mechanical phenomena.

In recent years, he has been actively involved in the research and promotion of national innovation policies.

The ceremonial Jubilee Celebration on the occasion of Prof. Michał Kleiber's 70th birthday was held on January 25, 2016 at the Auditorium of IPPT PAN.

The ceremony was honored by the presence of many distinguished representatives of the Polish researchers community. The guests were greeted by Prof. Tadeusz Burczyński, Director of IPPT PAN.

The Director presented the Jubilarian's profile and achievements, paying him deep respect and esteem on behalf of the Scientific Board and the whole Institute community for 44 years of Prof. Kleiber's creative and devoted work at the Institute.

All the invited guests had then the opportunity to listen to speeches given by former and current collaborators of Prof. Kleiber, including Prof. Jerzy Kleer (Institute of Economic Sciences of the Polish Academy of Sciences), Edwin Bendyk (Polityka – a highly respected weekly magazine), Assoc. Prof. Piotr Kowalczyk (IPPT PAN) and Prof. Jerzy Rojek (IPPT PAN). "Restless minds",

a film featuring Prof. Kleiber was shown, followed by his festive lecture on the role of scientific research in facing global societal and economic challenges.

At the end of the ceremony numerous representatives of institutions with which the Jubilarian has cooperated for many years congratulated him on his scientific accomplishments.



**Fig. 16.1.** Opening speech by Prof. Tadeusz Burczyński - Director of IPPT PAN



**Fig. 16.2. (left)** Prof. Michał Kleiber received congratulations from Prof. Tadeusz Burczyński - Director of IPPT PAN



**Fig. 16.3. (left, below)** Participants of the Ceremony

**Fig. 16.4. (below)** Prof. Kleiber with his wife, Teresa Sukniewicz-Kleiber, cutting the cake with IPPT PAN logo at the formal jubilee banquet



**Fig. 16.5.** A commemorative photo of Prof. Michał Kleiber with his nearest, long-time colleagues from the former Department of Computational Science IPPT PAN (now: the Department of Information and Computational Science)

Left to right are: Jarosław Knabel, Ph.D., Assoc. Prof. Piotr Kowalczyk, Assoc. Prof. Rafał Stocki, Prof. Michał Kleiber, Prof. Jerzy Rojek, Piotr Tazowski, Ph.D. and Bartłomiej Błachowski, Ph.D.

# 17. THE WITOLD NOWACKI LIBRARY

The IPPT PAN Library is one of the oldest and largest libraries at the Polish Academy of Sciences and is also nationally recognized. The Library mission is to provide access to knowledge resources for study and research work. For achieving its mission the IPPT PAN Library continues participating in selected academic and scientific libraries forums:

- the Consortium for the Scientific Libraries of the Polish Academy of Sciences for developing the union bibliographic database and catalogue of the libraries with memberships in the project,
- the Virtual Library of Science (coordinated by the Interdisciplinary Centre for Mathematical and Computational Modelling of the Warsaw University),
- the Consortium of the Open Resources in the Digital Repository of Scientific Institutes for increasing digital collections of the open access publications of 16 scientific libraries of the Polish Academy of Sciences.

The IPPT PAN Library activity is mainly focusing on:

- making print and electronic resources available within the Library's reading room and over the Internet through Polish libraries resource-sharing consortiums and networks,
- the Library's own print and electronic collections of books and journals gathering and protecting, including classification and cataloguing using bibliographic metadata standards, as well as selected collections digital preservation,
- providing reference service to the Library users based on the electronic catalogue of its own collections, also Polish and World libraries catalogues and other resources of bibliographic information,
- bibliometric analysis of scientific publications,
- print publications interchanging between the IPPT PAN and over 60 scientific institutions both national and foreign.

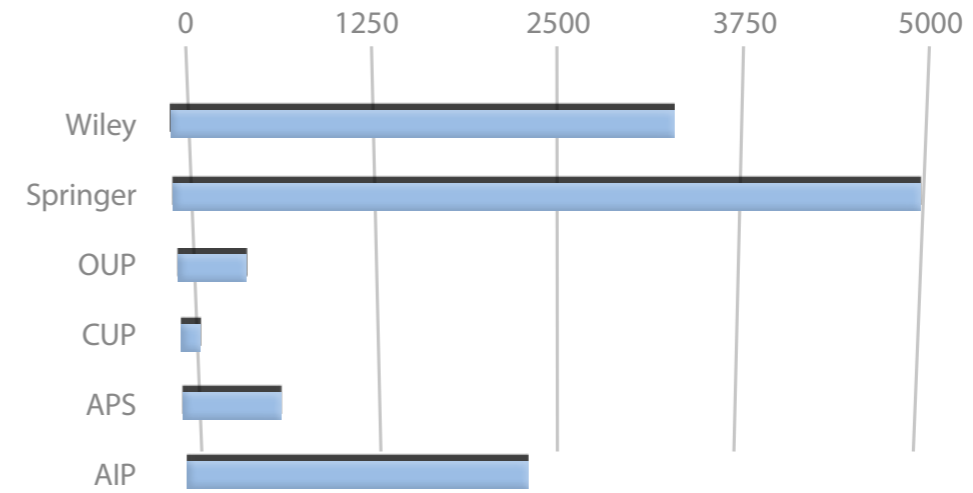
**Contact:**

**Head: Bogusława Lewandowska-Gruszka, Ph.D.**

**e-mail: [blewando@ippt.pan.pl](mailto:blewando@ippt.pan.pl)**

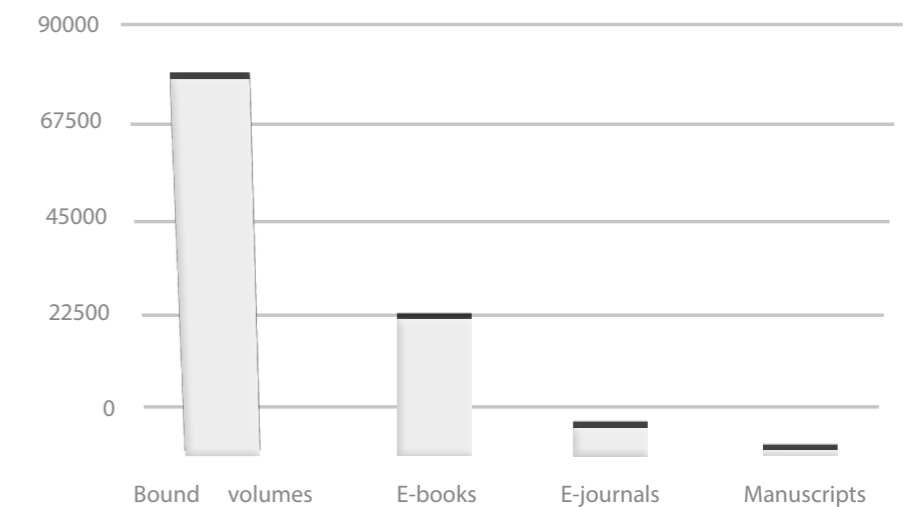
**phone: +48 22 826 74 10 or +48 22 826 12 81 ext. 247**

The Library provides all visitors with computers with research access to electronic catalogues, e-books and e-periodicals databases and other licensed resources. In 2016, the Library electronic resources were very readily used (Fig. 17.1).



The Library continues developing its print and electronic collections, including gathering and recording scientific dissertations, papers and other publications of scientists affiliated with the IPPT PAN (Fig. 17.2). Moreover, exhibitions of print literary output of the IPPT PAN outstanding scholars are organized by the Library.

**Fig. 17.1.** Full-text journals articles of selected publishers downloaded in the IPPT PAN Library in 2016: Wiley journals - 3265, Springer journals - 4869, Oxford University Press journals - 458, Cambridge University Press journals - 121, American Physical Society journals - 656, American Institute of Physics journals - 2302



**Fig. 17.2.** The Library stock as of October 31, 2017: 85603 bound volumes, 32206 electronic books, 7121 current electronic periodicals, 728 manuscripts

# 18. PUBLISHING OFFICE

## Scientific journals presently published by IPPT PAN:



**Archives of Acoustics** is an English-language peer-reviewed quarterly journal publishing original research papers from all areas of acoustics, and abstracts from selected acoustics conferences.

Beginning in 1990, all manuscripts published in AA are available online on the journal's website.

<http://acoustics.ippt.pan.pl/>

The papers are indexed and abstracted (from vol. 32(1) 2007) in Science Citation Index Expanded (SciSearch) and Journal Citation Reports.

Impact Factor 2016: 0.816

5-Year IF 2016: 0.835

Editor-in-chief: Prof. Andrzej Nowicki



**Archives of Mechanics** is a refereed international journal founded in 1949. It is edited and published by IPPT PAN.

The journal provides a forum for original research on the mechanics of solids, fluids and discrete systems, including the development of mathematical methods for solving mechanical problems.

<http://am.ippt.pan.pl/>

Archives of Mechanics is abstracted/indexed in:

Science Citation Index Expanded (SciSearch, Thomson ISI, Philadelphia), ISI Alerting Services, Current Contents/Engineering, Computing and Technology, Materials Science Citation Index, EBSCO Academic Search Complete, Applied Mechanics Reviews, Current Mathematical Publications, Mathematical Reviews, MathSci, Zentralblatt für Mathematik, UnCover, Inspec.

Impact Factor 2016: 1.157

5-Year Impact Factor 2016: 1.061

Editor-in-chief: Prof. Henryk Petryk



**Computer Assisted Methods** in Engineering and Sciences (CAMES) – formerly (up to 2011) Computer Assisted Mechanics and Engineering Sciences - is a refereed international journal, published quarterly, providing a scientific exchange forum and an authoritative source of information in the field of broadly understood computational engineering and applied sciences.

<http://cames.ippt.pan.pl/>

The objective of the journal is to support researchers and practitioners by offering them a means of facilitating access to newest research results reported by leading experts in the field, publication of own contributions and dissemination of information relevant to the scope of the journal.

CAMES is published under the auspices of the European Community on Computational Methods in Applied Sciences (ECCOMAS).

The journal also publishes book reviews and information on activities of the European Community on Computational Methods in Applied Sciences (ECCOMAS).

CAMES is abstracted/indexed in: Applied Mechanics Reviews, Current Mathematical Publications, Inspec, Mathematical Reviews, MathSci, Zentralblatt für Mathematik.

Editor-in-chief: Prof. Michał Kleiber, Co-editor-in-chief: Prof. Tadeusz Burczyński



**Engineering Transactions** – formerly *Rozprawy Inżynierskie* – is a refereed international journal founded in 1952 at the IPPT PAN.

Since 2011 the journal has been published by IPPT PAN in cooperation with the National Engineering School of Metz (Ecole Nationale d'Ingénieurs de Metz – ENIM), and since 2014 in cooperation with Poznań University of Technology.

<http://et.ippt.pan.pl/>

Engineering Transactions is abstracted/indexed in: Applied Mechanics Reviews, Current Mathematical Publications, Inspec, Mathematical Reviews, MathSci, Scopus, Zentralblatt für Mathematik.

Editor-in-chief: Assoc. Prof. Katarzyna Kowalczyk-Gajewska (IPPT PAN), co-editor-in-chief: Prof. Alexis Rusinek (ENIM), co-editor-in-chief: Prof. Tomasz Łodygowski (Poznań University of Technology).



### IPPT Reports on Fundamental Technological Research

The journal „IPPT Reports on Fundamental Technological Research” (IPPT Reports on FTR) is the international open-access publishing medium for high quality research focused on fundamental aspects of applied science and engineering. (Former title: „Prace IPPT - IFTR Reports”).

<http://reports.ippt.pan.pl>

The scope of the journal includes - among others - theoretical, experimental and computational research in mechanics and materials science, acoustics and electronics, fluid and molecular physics, photonics and plasmonics, physics of nanostructures, crystals and polymers, ultrasonic medical diagnostics, interdisciplinary physics in biology and medicine, informatics and applied mathematics, as well as the development of advanced numerical methods within a broad range of science and engineering.

Editor-in-chief: Prof. dr hab. Wojciech Nasalski

Production Editor: Bogusław Lempkowski

Total circulation of journals (hard copies): Year 2016 - 4330, Year 2017 - 3940

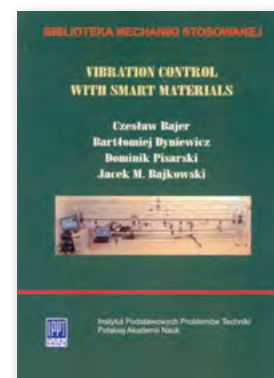
Total circulation of books: Year 2016 – 900, Year 2017 - 350

### In addition to journals the Editorial Office of IPPT PAN publishes five book series (in Polish and in English):

#### • LIBRARY OF APPLIED MECHANICS (BIBLIOTEKA MECHANIKI STOSOWANEJ)

Editor: Prof. Zenon Mróz

Last published:



#### 1. Czesław Bajer, Bartłomiej Dyniewicz, Dominik Pisarski, Jacek M. Bajkowski – **Vibration Control with Smart Materials**

Elimination of vibration is an important task in the period of rapid technological development. Although the theoretical basis on the vibration mitigation was created many years ago, practical solutions are not sufficiently implemented. The vibration theory and the control theory are the basis of considerations.

The book is addressed to Ph.D. students, researchers, and engineers. It covers the fields of control of structures in civil engineering and machinery engineering. The reader can also find and learn about the theoretical background of structural vibrations, optimal semi-active control strategies and examples of numerical simulations of real-life engineering structures. Nonclassical materials will deliver data that could be used in further research.

#### 2. Janina Ostrowska-Maciejewska, Katarzyna Kowalczyk-Gajewska – **Rachunek tensorowy w mechanice ośrodków ciągłych** (*Tensor calculus in continuum mechanics*). In Polish.

#### • LIBRARY OF ACOUSTICS AND ULTRASOUNDS (BIBLIOTEKA AKUSTYKI I ULTRADŹWIĘKÓW)

Editor: Prof. Andrzej Nowicki

Last published:

Andrzej Nowicki - **Ultradźwięki w medycynie - wprowadzenie do współczesnej ultrasonografii** (*Ultrasounds in medicine - introduction to modern ultrasonography*). In Polish.

#### • TRENDS IN MECHANICS OF MATERIALS (TRENDY W MECHANICE MATERIAŁÓW)

Editor: Prof. Zenon Mróz

Last published:

Wojciech Nasalski – **Optical beams at dielectric interfaces - fundamentals**

#### • TECHNOLOGICAL MECHANICS (MECHANIKA TECHNICZNA)

Editor: Prof. Witold Gutkowski

Last published:

Romuald Będziński (Editor) - **Biomechanika** (*Biomechanics*). In Polish.

#### • LIBRARY OF SCIENTISTS' REFLECTION (BIBLIOTEKA REFLEKSJI NAUKOWEJ)

Editor: Prof. Tadeusz Burczyński

Last published:

Michał Kleiber – **Mądra Polska** (*Wise Poland*). In Polish.

Kazimierz Sobczyk – **O meandrach życia i stochastyce – optymistycznie. Opowieść Autobiograficzna** (*The turns of life and stochastics - optimistic autobiography*). In Polish.

In 2017, also published by IPPT PAN was the “2016 Report” of IUTAM (International Union of Theoretical and Applied Mechanics).

#### Contact:

Head: Bogusław Lempkowski, M.Sc.

e-mail: [blemp@ippt.pan.pl](mailto:blemp@ippt.pan.pl)

phone: +48 22 826 60 22 or +48 22 826 12 81 ext. 208

## 19. POPULARIZATION OF SCIENCE

IPPT PAN has been involved in various public events aiming at the popularization of science, such as the Science Festival and the Science Picnic of the Polish Radio and the Copernicus Science Centre. Both of the events have greatly contributed to fostering the popularization of science and appreciation of scientists among members of the public.

### THE SCIENCE PICNIC IN 2016-2017

Figs 19.1-3. Presentations for children and families



### THE SCIENCE FESTIVAL IN 2016-2017

Figs 19.4-6. Presentations for schoolchildren and students



## 20. ADMINISTRATION UNITS (AS OF 31 DECEMBER 2017)

### CENTRE OF TECHNOLOGY

**Head: Andrzej Siemaszko, Ph.D.**

e-mail: [asiemasz@ippt.pan.pl](mailto:asiemasz@ippt.pan.pl)

phone: +48 22 826 12 81 ext. 102

### ACCOUNTING OFFICE

**Head: Emilia Lankiewicz, M.Sc.**

e-mail: [elankiew@ippt.pan.pl](mailto:elankiew@ippt.pan.pl)

phone: +48 22 826 98 02, +48 22 826 12 81 ext. 119

### LIBRARY

**Head: Bogusława Lewandowska-Gruszka, Ph.D.**

e-mail: [library@ippt.pan.pl](mailto:library@ippt.pan.pl)

phone: +48 22 826 74 10, +48 22 826 12 81 ext. 247

### HUMAN RESOURCES OFFICE

**Head: Agnieszka Milczarek, M.Sc.**

e-mail: [kadry@ippt.pan.pl](mailto:kadry@ippt.pan.pl)

phone: +48 22 826 98 23, +48 22 826 12 81 ext. 123

### PROJECTS MANAGEMENT AND RESEARCH COORDINATION OFFICE

**Head: Monika Milewska, M.Sc.**

e-mail: [mmile@ippt.pan.pl](mailto:mmile@ippt.pan.pl)

phone: +48 22 826 12 81 ext. 299

### CENTRE FOR COMMERCIALIZATION OF RESEARCH RESULTS AND TECHNOLOGY TRANSFER

**Head: Teresa Pawełek, M.Sc.**

e-mail: [tpawelek@ippt.pan.pl](mailto:tpawelek@ippt.pan.pl)

phone: +48 22 826 12 81 ext. 145

### DOCTORAL STUDY OFFICE

**Secretary: Monika Węglowska**

e-mail: [mweglow@ippt.pan.pl](mailto:mweglow@ippt.pan.pl)

phone: +48 22 826 98 41, +48 22 826 12 81 ext. 219

### PUBLISHING OFFICE

**Head: Bogusław Lempkowski, M.Sc.**

e-mail: [blemp@ippt.pan.pl](mailto:blemp@ippt.pan.pl)

phone: +48 22 826 60 22, +48 22 826 12 81 ext. 208

### SECRETARY AND ADMINISTRATIVE OFFICE

**Head: Aneta Ciesielska, B.Sc.**

e-mail: [aciesiel@ippt.pan.pl](mailto:aciesiel@ippt.pan.pl)

phone: +48 22 828 53 73, +48 22 826 12 81 ext. 114

### INTERNATIONAL COOPERATION OFFICE

**Head: Joanna Małachowska-Tymkiewicz**

e-mail: [jmalat@ippt.pan.pl](mailto:jmalat@ippt.pan.pl)

phone: +48 22 826 65 93, +48 22 826 12 81 ext. 142

### COMPUTING SERVICES

**Head: Mikołaj Dybko, M.Sc.**

e-mail: [mdybko@ippt.pan.pl](mailto:mdybko@ippt.pan.pl)

phone: +48 22 826 12 81 ext. 277

### ADMINISTRATIVE AND TECHNICAL SERVICES

**Head: Marek Wieczoryński**

e-mail: [mwiecz@ippt.pan.pl](mailto:mwiecz@ippt.pan.pl)

phone: +48 22 826 12 81 ext. 104

# 2016-2017 PUBLICATIONS

## PAPERS IN JOURNALS INDEXED IN WEB OF SCIENCE, 2016

- Dimcevski G., Kotopoulos S., Bjånes T., Hoem D., Schjøl T., Gjertsen B.T., Biermann M., Molven A., Sorbye H., McCormack E., Postema M., Gilja O.H., A human clinical trial using ultrasound and microbubbles to enhance gemcitabine treatment of inoperable pancreatic cancer, *Journal of Controlled Release*, ISSN: 0168-3659, DOI: 10.1016/j.jconrel.2016.10.007, Vol.243, pp.172-181, 2016
- Chmielewski M., Nosewicz S., Kurpaska Ł., Romelczyk B., Evolution of material properties during the sintering process of Cr-Re-Al<sub>2</sub>O<sub>3</sub> composites, *COMPOSITES PART B-ENGINEERING*, ISSN: 1359-8368, DOI: 10.1016/j.compositesb.2016.04.065, Vol.98, pp.88-96, 2016
- Konowrocki R., Szolc T., Pochanke A., Pęgowska A., An influence of the stepping motor control and friction models on precise positioning of the complex mechanical system, *MECHANICAL SYSTEMS AND SIGNAL PROCESSING*, ISSN: 0888-3270, DOI: 10.1016/j.ymsp.2015.09.030, Vol.70-71, pp.397-413, 2016
- Bajkowski J.M., Dyniewicz B., Bajer C.I., Semi-active damping strategy for beams system with pneumatically controlled granular structure, *MECHANICAL SYSTEMS AND SIGNAL PROCESSING*, ISSN: 0888-3270, DOI: 10.1016/j.ymsp.2015.09.026, Vol.70-71, pp.387-396, 2016
- Hat B., Kochańczyk M., Bogdał M.N., Lipniacki T., Feedbacks, bifurcations, and cell fate decision-making in the p53 system, *PLOS COMPUTATIONAL BIOLOGY*, ISSN: 1553-734X, DOI: 10.1371/journal.pcbi.1004787, Vol.12, No.2, pp.e1004787-1-28, 2016
- Chikahiro Y., Ario I., Nakazawa M., Ono S., Holnicki-Szulc J., Pawłowski P., Graczykowski C., Watson A., Experimental and numerical study of full-scale scissor type bridge, *Automation in Construction*, ISSN: 0926-5805, DOI: 10.1016/j.autcon.2016.05.007, Vol.71, pp.171-180, 2016
- Domagała J.Z., Morelão S.L., Sarzyński M., Maździarz M., Dłużewski P., Leszczyński M., Hybrid reciprocal lattice: application to layer stress determination in GaIn/GaN(0001) systems with patterned substrates, *JOURNAL OF APPLIED CRYSTALLOGRAPHY*, ISSN: 1600-5767, DOI: 10.1107/S1600576716004441, Vol.49, No.3, pp.798-805, 2016
- Stobiecka M., Dworakowska B., Jakiela S., Lukasiak A., Chalupa A., Zembrzycki K., Sensing of survivin mRNA in malignant astrocytes using graphene oxide nanocarrier-supported oligonucleotide molecular beacons, *Sensors and Actuators B: Chemical*, ISSN: 0925-4005, DOI: 10.1016/j.snb.2016.04.176, Vol.235, pp.136-145, 2016
- Graczykowski C., Mathematical models and numerical methods for the simulation of adaptive inflatable structures for impact absorption, *COMPUTERS AND STRUCTURES*, ISSN: 0045-7949, DOI: 10.1016/j.compstruc.2015.06.017, Vol.174, pp.3-20, 2016
- Schabowicz K., Ranachowski Z., Józwiak-Niedźwiedzka D., Radzik Ł., Kúdela Jr S., Dvorak T., Application of X-ray microtomography to quality assessment of fibre cement boards, *CONSTRUCTION AND BUILDING MATERIALS*, ISSN: 0950-0618, DOI: 10.1016/j.conbuildmat.2016.02.035, Vol.110, pp.182-188, 2016
- Dąbrowski M., Glinicki M.A., Gibas K., Józwiak-Niedźwiedzka D., Effects of calcareous fly ash in blended cements on chloride ions migration and strength of air entrained concrete, *CONSTRUCTION AND BUILDING MATERIALS*, ISSN: 0950-0618, DOI: 10.1016/j.conbuildmat.2016.08.115, Vol.126, pp.1044-1053, 2016
- Davydov D., Young T.D., Steinmann P., On the adaptive finite element analysis of the Kohn-Sham equations: methods, algorithms, and implementation, *INTERNATIONAL JOURNAL FOR NUMERICAL METHODS IN ENGINEERING*, ISSN: 0029-5981, DOI: 10.1002/nme.5140, Vol.106, pp.863-888, 2016
- Wajnryb E., Mizerski K., Short-time self-diffusion, collective diffusion and effective viscosity of dilute hard sphere magnetic suspensions, *JOURNAL OF FLUID MECHANICS*, ISSN: 0022-1120, DOI: 10.1017/jfm.2016.48, Vol.791, pp.237-259, 2016
- Feuillebois F., Ekiel-Jezewska M.L., Wajnryb E., Sellier A., Bławdziewicz J., High-frequency effective viscosity of a dilute suspension of particles in Poiseuille flow between parallel walls, *JOURNAL OF FLUID MECHANICS*, ISSN: 0022-1120, DOI: 10.1017/jfm.2016.378, Vol.800, pp.111-139, 2016
- Tůma K., Stupkiewicz S., Petryk H., Size effects in martensitic microstructures: Finite-strain phase field model versus sharp-interface approach, *JOURNAL OF THE MECHANICS AND PHYSICS OF SOLIDS*, ISSN: 0022-5096, DOI: 10.1016/j.jmps.2016.04.013, Vol.95, pp.284-307, 2016
- Ziętek G., Mróz Z., A constitutive hardening model of coupled plastic deformation and martensitic transformation in steels, *MECHANICS OF MATERIALS*, ISSN: 0167-6636, DOI: 10.1016/j.mechmat.2016.06.004, Vol.100, pp.154-166, 2016
- Chrzanowska J., Kurpaska Ł., Giżyński M., Hoffman J., Szymański Z., Mościcki T., Fabrication and characterization of superhard tungsten boride layers deposited by radio frequency magnetron sputtering, *CERAMICS INTERNATIONAL*, ISSN: 0272-8842, DOI: 10.1016/j.ceramint.2016.04.166, Vol.42, No.10, pp.12221-12230, 2016
- Gradyś A., Sajkiewicz P., Zhuravlev E., Schick C., Kinetics of isothermal and non-isothermal crystallization of poly(vinylidene fluoride) by fast scanning calorimetry, *POLYMER*, ISSN: 0032-3861, DOI: 10.1016/j.polymer.2015.11.020, Vol.82, pp.40-48, 2016
- Faraj R., Holnicki-Szulc J., Knap L., Serńko J., Adaptive inertial shock-absorber, *SMART MATERIALS AND STRUCTURES*, ISSN: 0964-1726, DOI: 10.1088/0964-1726/25/3/035031, Vol.25, pp.035031-1-9, 2016
- Pieczyska E.A., Staszczak M., Maj M., Kowalczyk-Gajewska K., Golasirski K., Cristea M., Tobushi H., Hayashi S., Investigation of thermomechanical couplings, strain localization and shape memory properties in a shape memory polymer subjected to loading at various strain rates, *SMART MATERIALS AND STRUCTURES*, ISSN: 0964-1726, DOI: 10.1088/0964-1726/25/8/085002, Vol.25, No.8, pp.085002-1-15, 2016
- Farutin A., Piasecki T., Słowicka A.M., Misbah C., Wajnryb E., Ekiel-Jezewska M.L., Dynamics of flexible fibers and vesicles in Poiseuille flow at low Reynolds number, *SOFT MATTER*, ISSN: 1744-683X, DOI: 10.1039/c6sm00819d, Vol.12, pp.7307-7323, 2016

- Adamowicz J., Pokrywczyńska M., Tworkiewicz J., Kowalczyk T., van Breda S.V., Tyloch D., Kloskowski T., Bodnar M., Skopińska-Wiśniewska J., Marszałek A., Frontczak-Baniewicz M.M., Kowalewski T.A., Drewno T., New Amniotic Membrane Based Biocomposite for Future Application in Reconstructive Urology, *PLOS ONE*, ISSN: 1932-6203, DOI: 10.1371/journal.pone.0146012, Vol.11, No.1, pp.e0146012-1-20, 2016
- Maździarz M., Mościcki T., Structural, mechanical, optical, thermodynamical and phonon properties of stable ReB<sub>2</sub> polymorphs from density functional calculations, *JOURNAL OF ALLOYS AND COMPOUNDS*, ISSN: 0925-8388, DOI: 10.1016/j.jallcom.2015.10.133, Vol.657, pp.878-888, 2016
- Józwiak-Niedźwiedzka D., Jaskulski R., Glinicki M.A., Application of Image Analysis to Identify Quartz Grains in Heavy Aggregates Susceptible to ASR in Radiation Shielding Concrete, *Materials*, ISSN: 1996-1944, DOI: 10.3390/ma9040224, Vol.9, No.4, pp.224-1-14, 2016
- Glinicki M.A., Józwiak-Niedźwiedzka D., Gibas K., Dąbrowski M., Influence of Blended Cements with Calcareous Fly Ash on Chloride Ion Migration and Carbonation Resistance of Concrete for Durable Structures, *Materials*, ISSN: 1996-1944, DOI: 10.3390/ma9010018, Vol.9, No.1 (Special Issue: Utilisation of By-Product Materials in Concrete), pp.18-1-15, 2016
- Byra M., Nowicki A., Piotrkowska-Wróblewska H., Dobruch-Sobczak K., Classification of breast lesions using segmented quantitative ultrasound maps of homodyned K distribution parameters, *Medical Physics*, ISSN: 0094-2405, DOI: 10.1118/1.4962928, Vol.43, No.10, pp.5561-5569, 2016
- Dulnik J., Denis P., Sajkiewicz P., Kołbuk D., Chorońska E., Biodegradation of bicomponent PCL/gelatin and PCL/collagen nanofibers electrospun from alternative solvent system, *Polymer Degradation and Stability*, ISSN: 0141-3910, DOI: 10.1016/j.polymerdegradstab.2016.05.022, Vol.130, pp.10-21, 2016
- Taczała M., Buczkowski R., Kleiber M., Nonlinear free vibration of pre- and post-buckled FGM plates on two-parameter foundation in the thermal environment, *COMPOSITE STRUCTURES*, ISSN: 0263-8223, DOI: 10.1016/j.compstruct.2015.11.017, Vol.137, pp.85-92, 2016
- Graczykowski C., Orłowska A., Holnicki-Szulc J., Prestressed composite structures – Modelling, manufacturing, design, *COMPOSITE STRUCTURES*, ISSN: 0263-8223, DOI: 10.1016/j.compstruct.2016.02.085, Vol.151, pp.172-182, 2016
- Ozgowicz W., Grzegorzczak B., Pawełek A., Wajda W., Skuza W., Piątkowski A., Ranachowski Z., An analysis of the Portevin-Le Chatelier effect and cracking of Cu<sub>3</sub>Sn<sub>6</sub>P alloy at elevated temperature of deformation applying the acoustic emission method, *ENGINEERING FRACTURE MECHANICS*, ISSN: 0013-7944, DOI: 10.1016/j.engfracmech.2016.04.036, Vol.167, pp.112-122, 2016
- Błachowski B., Gutkowski W., Effect of damaged circular flange-bolted connections on behaviour of tall towers, modelled by multilevel substructuring, *ENGINEERING STRUCTURES*, ISSN: 0141-0296, DOI: 10.1016/j.engstruct.2015.12.018, Vol.111, pp.93-103, 2016
- Korwek Z., Tudelska K., Nałęcz-Jawecki P., Czerkies M., Prus W., Markiewicz J., Kochańczyk M., Lipniacki T., Importins promote high-frequency NF-κB oscillations increasing information channel capacity, *Biology Direct*, ISSN: 1745-6150, DOI: 10.1186/s13062-016-0164-z, Vol.11, No.61, pp.1-21, 2016
- Kucharski S., Jarzabek D., Piątkowska A., Woźniacka S., Decrease of Nano-hardness at Ultra-low Indentation Depths in Copper Single Crystal, *EXPERIMENTAL MECHANICS*, ISSN: 0014-4851, DOI: 10.1007/s11340-015-0105-2, Vol.56, No.3, pp.381-393, 2016
- Temizer I., Stupkiewicz S., Formulation of the Reynolds equation on a time-dependent lubrication surface, *PROCEEDINGS OF THE ROYAL SOCIETY A-MATHEMATICAL PHYSICAL AND ENGINEERING SCIENCES*, ISSN: 1364-5021, DOI: 10.1098/rspa.2016.0032, Vol.472, pp.20160032-1-16, 2016
- Tůma K., Stupkiewicz S., Phase-field study of size-dependent morphology of austenite-twin martensite interface in CuAlNi, *INTERNATIONAL JOURNAL OF SOLIDS AND STRUCTURES*, ISSN: 0020-7683, DOI: 10.1016/j.ijsolstr.2016.07.040, Vol.97-98, pp.89-100, 2016
- Cichocki B., Ekiel-Jezewska M.L., Wajnryb E., Note: Brownian motion of colloidal particles of arbitrary shape, *JOURNAL OF CHEMICAL PHYSICS*, ISSN: 0021-9606, DOI: 10.1063/1.4942119, Vol.144, pp.076101-1-2, 2016
- Lisicki M., Cichocki B., Wajnryb E., Near-wall diffusion tensor of an axisymmetric colloidal particle, *JOURNAL OF CHEMICAL PHYSICS*, ISSN: 0021-9606, DOI: 10.1063/1.4958727, Vol.145, pp.034904-1-8, 2016
- Szmidt T., Shear deformation damping of a double-beam structure, *JOURNAL OF SOUND AND VIBRATION*, ISSN: 0022-460X, DOI: 10.1016/j.jsv.2016.01.044, Vol.370, pp.163-175, 2016
- Pisarski D., Bajer C.I., Dyniewicz B., Bajkowski J.M., Vibration control in smart coupled beams subjected to pulse excitations, *JOURNAL OF SOUND AND VIBRATION*, ISSN: 0022-460X, DOI: 10.1016/j.jsv.2016.05.050, Vol.380, pp.37-50, 2016
- Moćko W., Grzywna P., Kowalewski Z.L., Radziejewska J., An influence of cyclic loading on the form of constitutive relationship for DP500 steel, *MATERIALS AND DESIGN*, ISSN: 0261-3069, DOI: 10.1016/j.matdes.2016.04.075, Vol.103, pp.183-193, 2016
- Frydrych K., Kowalczyk-Gajewska K., A three-scale crystal plasticity model accounting for grain refinement in fcc metals subjected to severe plastic deformations, *MATERIALS SCIENCE AND ENGINEERING A-STRUCTURAL MATERIALS PROPERTIES MICROSTRUCTURE AND PROCESSING*, ISSN: 0921-5093, DOI: 10.1016/j.msea.2016.01.101, Vol.658, pp.490-502, 2016
- Řehoř M., Průša V., Tůma K., On the response of nonlinear viscoelastic materials in creep and stress relaxation experiments in the lubricated squeeze flow setting, *PHYSICS OF FLUIDS*, ISSN: 1070-6631, DOI: 10.1063/1.4964662, Vol.28, No.10, pp.103102-1-25, 2016
- Chmielewski M., Nosewicz S., Jakubowska D., Lewandowska M., Mizera J., Rojek J., Bazarnik P., The influence of sintering time on the microstructural properties of chromium-rhenium matrix composites, *International Journal of Refractory Metals and Hard Materials*, ISSN: 0263-4368, DOI: 10.1016/j.ijrmhm.2016.05.017, Vol.59, pp.78-86, 2016
- Chmielewski M., Pietrzak K., Basista M., Węglewski W., Rhenium doped chromium-alumina composites for high-temperature applications, *International Journal of Refractory Metals and Hard Materials*, ISSN: 0263-4368, DOI: 10.1016/j.ijrmhm.2015.07.012, Vol.54, pp.196-202, 2016

45. An Y., Błachowski B., Ou J., A degree of dispersion-based damage localization method, STRUCTURAL CONTROL AND HEALTH MONITORING, ISSN: 1545-2255, DOI: 10.1002/stc.1760, Vol.23, pp.176-192, 2016
46. Winnicki M., Małachowska A., Baszczuk A., Rutkowska-Gorczyca M., Kukla D., Lachowicz M., Ambroziak A., Corrosion protection and electrical conductivity of copper coatings deposited by low-pressure cold spraying, SURFACE AND COATINGS TECHNOLOGY, ISSN: 0257-8972, DOI: 10.1016/j.surfcoat.2016.12.101, pp.1-19, 2016
47. Stupkiewicz S., Lengiewicz J., Sadowski P., Kucharski S., Finite deformation effects in soft elastohydrodynamic lubrication problems, TRIBOLOGY INTERNATIONAL, ISSN: 0301-679X, DOI: 10.1016/j.triboint.2015.03.016, Vol.93, pp.511-522, 2016
48. Buczkowski R., Kleiber M., A study of the surface roughness in elasto-plastic shrink fitted joint, TRIBOLOGY INTERNATIONAL, ISSN: 0301-679X, DOI: 10.1016/j.triboint.2016.02.021, Vol.98, pp.125-132, 2016
49. Pnevmatikos N.G., Błachowski B., Hatzigeorgiou G.D., Świercz A., Wavelet analysis based damage localization in steel frames with bolted connections, SMART STRUCTURES AND SYSTEMS, ISSN: 1738-1584, DOI: 10.12989/sss.2016.18.6.1189, Vol.18, No.6, pp.1189-1202, 2016
50. Błachowski B., Świercz A., Gutkiewicz P., Szelażek J., Gutkowski W., Structural damage detectability using modal and ultrasonic approaches, MEASUREMENT, ISSN: 0263-2241, DOI: 10.1016/j.measurement.2016.02.033, Vol.85, pp.210-221, 2016
51. Urbanek O., Pierini F., Choińska E., Sajkiewicz P., Bil M., Świąszkowski W., Effect of hydroxyapatite nanoparticles addition on structure properties of poly (L-lactide-co-glycolide) after gamma sterilization, Polymer Composites, ISSN: 0272-8397, DOI: 10.1002/pc.24028, Vol.1, pp.1-9, 2016
52. Jas G.S., Rentschler E.C., Slowicka A.M., Hermansen J.R., Johnson C.K., Middaugh C.R., Kuczera K., Reorientation Motion and Preferential Interactions of a Peptide in Denaturants and Osmolyte, JOURNAL OF PHYSICAL CHEMISTRY B, ISSN: 1520-6106, DOI: 10.1021/acs.jpcc.6b00028, Vol.120, pp.3089-3099, 2016
53. Pierini F., Lanzi M., Nakielski P., Pawłowska S., Zembrzycki K., Kowalewski T.A., Electrospun poly (3-hexylthiophene)/poly(ethylene oxide)/graphene oxide composite nanofibers: effects of graphene oxide reduction, Polymers for Advanced Technologies, ISSN: 1042-7147, DOI: 10.1002/pat.3816, Vol.27, No.11, pp.1465-1475, 2016
54. van Leusden P., den Hartog G.J.M., Bast A., Postema M., van der Linden E., Sagis L.M.C., Structure engineering of filled protein microbeads to tailor release of oil droplets in gastric digestion, Food and Function, ISSN: 2042-6496, DOI: 10.1039/c6fo00405a, Vol.7, pp.3539-3547, 2016
55. Jurczak G., Dłużewski P., Finite element modelling of nonlinear piezoelectricity in wurtzite GaN/AlN quantum dots, COMPUTATIONAL MATERIALS SCIENCE, ISSN: 0927-0256, DOI: 10.1016/j.commatsci.2015.09.024, Vol.111, pp.197-202, 2016
56. Ranachowski P., Ranachowski Z., Jaroszewski M., Wieczorek K., Kúdela Jr S., Mechanoacoustic Research Method of Degradation Processes in Electroceramics Materials, IEEE TRANSACTIONS ON DIELECTRICS AND ELECTRICAL INSULATION, ISSN: 1070-9878, DOI: 10.1109/TDEI.2015.005568, Vol.23, No.3, pp.1251-1259, 2016
57. Klimonda Z., Postema M., Nowicki A., Litniewski J., Tissue Attenuation Estimation by Mean Frequency Downshift and Bandwidth Limitation, IEEE TRANSACTIONS ON ULTRASONICS FERROELECTRICS AND FREQUENCY CONTROL, ISSN: 0885-3010, DOI: 10.1109/TUFFC.2016.2574399, Vol.63, No.8, pp.1107-1115, 2016
58. Teisseyre H., Kaminska A., Birner S., Young T.D., Suchocki A., Kozanecki A., Influence of hydrostatic pressure on the built-in electric field in ZnO/ZnMgO quantum wells, JOURNAL OF APPLIED PHYSICS, ISSN: 0021-8979, DOI: 10.1063/1.4953251, Vol.119, pp.215702-1-8, 2016
59. Ziabicki A., Misztal-Faraj B., Jarecki L., Kinetic model of non-isothermal crystal nucleation with transient and athermal effects, JOURNAL OF MATERIALS SCIENCE, ISSN: 0022-2461, DOI: 10.1007/s10853-016-0145-8, Vol.51, pp.8935-8952, 2016
60. Maździarz M., Mościcki T., Structural, mechanical and optical properties of potentially superhard WBx polymorphs from first principles calculations, MATERIALS CHEMISTRY AND PHYSICS, ISSN: 0254-0584, DOI: 10.1016/j.matchemphys.2016.05.014, Vol.179, pp.92-102, 2016
61. Staszczak M., Pieczyska E., Maj M., Kukla D., Tobushi H., Infrared thermographic analysis of shape memory polymer during cyclic loading, MEASUREMENT SCIENCE AND TECHNOLOGY, ISSN: 0957-0233, DOI: 10.1088/0957-0233/27/12/124007, Vol.27, No.12, pp.124007-1-6, 2016
62. Pierini F., Zembrzycki K., Nakielski P., Pawłowska S., Kowalewski T.A., Atomic force microscopy combined with optical tweezers (AFM/OT), MEASUREMENT SCIENCE AND TECHNOLOGY, ISSN: 0957-0233, DOI: 10.1088/0957-0233/27/2/025904, Vol.27, pp.025904-1-11, 2016
63. Pągowska A., Szczepański J., Wajnryb E., Temporal code versus rate code for binary Information Sources, NEUROCOMPUTING, ISSN: 0925-2312, DOI: 10.1016/j.neucom.2016.08.034, Vol.216, pp.756-762, 2016
64. Young T.D., Vargas R., Garza J., A Hartree-Fock study of the confined helium atom: Local and global basis set approaches, PHYSICS LETTERS A, ISSN: 0375-9601, DOI: 10.1016/j.physleta.2015.11.021, Vol.380, pp.712-717, 2016
65. Kulakov S.V., Yakimov A.N., Bugaev A., Postema M., Voloshinov V.B., Wave electronics and applications thereof in information and telecommunication systems, APPLIED ACOUSTICS, ISSN: 0003-682X, DOI: 10.1016/j.apacoust.2016.06.017, Vol.112, No. Special issue, Preface, pp.216, 2016
66. Kielczyński P., Szalewski M., Balcerzak A., Wieja K., Propagation of ultrasonic Love waves in nonhomogeneous elastic functionally graded materials, Ultrasonics, ISSN: 0041-624X, DOI: 10.1016/j.ultras.2015.10.001, Vol.65, pp.220-227, 2016
67. Karwat P., Kujawska T., Lewin P.A., Secomski W., Gambin B., Litniewski J., Determining temperature distribution in tissue in the focal plane of the high (>100W/cm<sup>2</sup>) intensity focused ultrasound beam using phase shift of ultrasound echoes, Ultrasonics, ISSN: 0041-624X, DOI: 10.1016/j.ultras.2015.10.002, Vol.65, pp.211-219, 2016
68. Tasinkevych Y., Podhajecki J., Falińska K., Litniewski J., Simultaneous estimation of cortical bone thickness and acoustic wave velocity using a multivariable optimization approach: Bone phantom and in-vitro study, Ultrasonics, ISSN: 0041-624X, DOI: 10.1016/j.ultras.2015.10.013, Vol.65, pp.105-112, 2016
69. Gołubowska B., Some aspects of affine motion and nonholonomic constraints. Two ways to describe homogeneously deformable bodies, ZAMM-ZEITSCHRIFT FÜR ANGEWANDTE MATHEMATIK UND MECHANIK, ISSN: 0044-2267, DOI: 10.1002/zamm.201400192, Vol.96, No.8, pp.968-985, 2016

70. Marczevska I., Rojek J., Kačianauskas R., Investigation of the effective elastic parameters in the discrete element model of granular material by the triaxial compression test, ARCHIVES OF CIVIL AND MECHANICAL ENGINEERING, ISSN: 1644-9665, DOI: 10.1016/j.jacme.2015.09.010, Vol.16, pp.64-75, 2016
71. Będkowski J., Majek K., Majek P., Musialik P., Pełka M., Nüchter A., Intelligent Mobile System for Improving Spatial Design Support and Security Inside Buildings, Mobile Networks and Applications, ISSN: 1383-469X, DOI: 10.1007/s11036-015-0654-8, Vol.21, No.2, pp.313-326, 2016
72. Bajkowski J.M., Bajer C.I., Dyniewicz B., Pisarski D., Vibration control of adjacent beams with pneumatic granular coupler: an experimental study, Mechanics Research Communications, ISSN: 0093-6413, DOI: 10.1016/j.mechrescom.2016.10.005, Vol.78, pp.51-56, 2016
73. Malek J., Rajagopal K.R., Tüma K., A thermodynamically compatible model for describing asphalt binders: solutions of problems, International Journal of Pavement Engineering, ISSN: 1029-8436, DOI: 10.1080/10298436.2015.1007575, Vol.17, No.6, pp.550-564, 2016
74. Enayati M.S., Behzad T., Sajkiewicz P., Bagheri R., Ghasemi-Mobarakeh L., Łojkowski W., Pahlevanneshan Z., Ahmadi M., Crystallinity study of electrospun poly (vinyl alcohol) nanofibers: effect of electrospinning, filler incorporation, and heat treatment, IRANIAN POLYMER JOURNAL, ISSN: 1026-1265, DOI: 10.1007/s13726-016-0455-3, Vol.25, No.7, pp.647-659, 2016
75. Sumelka W., Nowak M., Non-normality and induced plastic anisotropy under fractional plastic flow rule: a numerical study, INTERNATIONAL JOURNAL FOR NUMERICAL AND ANALYTICAL METHODS IN GEOMECHANICS, ISSN: 0363-9061, DOI: 10.1002/nag.2421, Vol.40, pp.651-675, 2016
76. Kielczyński P., Szalewski M., Balcerzak A., Wieja K., Inverse Method for Determining Profiles of Elastic Parameters in the Functionally Graded Materials using Love Waves, ACTA ACUSTICA UNITED WITH ACUSTICA, ISSN: 1610-1928, DOI: 10.3813/AAA.918961, Vol.102, pp.428-435, 2016
77. Larecki W., Banach Z., Two-field radiation hydrodynamics in n spatial dimensions, JOURNAL OF PHYSICS A-MATHEMATICAL AND THEORETICAL, ISSN: 1751-8113, DOI: 10.1088/1751-8113/49/12/125501, Vol.49, No.12, pp.125501-1-23, 2016
78. Petryk H., Stupkiewicz S., A minimal gradient-enhancement of the classical continuum theory of crystal plasticity. Part I: The hardening law, ARCHIVES OF MECHANICS, ISSN: 0373-2029, Vol.68, No.6, pp.459-485, 2016
79. Stupkiewicz S., Petryk H., A minimal gradient-enhancement of the classical continuum theory of crystal plasticity. Part II: Size effects, ARCHIVES OF MECHANICS, ISSN: 0373-2029, Vol.68, No.6, pp.487-513, 2016
80. Pawełek A., Piątkowski A., Wajda W., Skuza W., Tarasek A., Ranachowski Z., Ranachowski P., Ozgowicz W., Kúdela Jr S., Kúdela S., Plastic instabilities induced by the Portevin - Le Châtelier effect and fracture character of deformed Mg-Li alloys investigated using the acoustic emission method, ARCHIVES OF METALLURGY AND MATERIALS, ISSN: 1733-3490, DOI: 10.1515/amm-2016-0152, Vol.61, No.2, pp.897-904, 2016
81. Ranachowski P., Ranachowski Z., Kúdela Jr S., Pawełek A., Piątkowski A., Study of factors determinant of siliceous electrical porcelain resistance to structural degradation, ARCHIVES OF METALLURGY AND MATERIALS, ISSN: 1733-3490, DOI: 10.1515/amm-2016-0244, Vol.61, No.3, pp.1143-1150, 2016
82. Kołbuk D., Guimond-Lischer S., Sajkiewicz P., Maniura-Weber K., Fortunato G., Morphology and surface chemistry of bicomponent scaffolds in terms of mesenchymal stromal cell viability, Journal of Bioactive and Compatible Polymers, ISSN: 0883-9115, DOI: 10.1177/0883911515621571, Vol.1, pp.1-14, 2016
83. Chatterjee P., Kaźmierczak B., Eigenfunction Approach to Transient Patterns in a Model of Chemotaxis, MATHEMATICAL MODELLING OF NATURAL PHENOMENA, ISSN: 0973-5348, DOI: 10.1051/mmnp/201611204, Vol.11, No.2, pp.44-62, 2016
84. Sulejczak D., Taraszewska A., Chrapusta S.J., Dziewulska D., Nakielski P., Rafałowska J., Nanofiber mat spinal cord dressing-released glutamate impairs blood-spinal cord barrier, FOLIA NEUROPATHOLOGICA, ISSN: 1641-4640, DOI: 10.5114/fn.2016.64818, Vol.54, No.4, pp.392-404, 2016
85. Bilmin K., Kujawska T., Secomski W., Nowicki A., Grieb P., 5-Aminolevulinic acid-mediated sonosensitization of rat RG2 glioma cells in vitro, FOLIA NEUROPATHOLOGICA, ISSN: 1641-4640, DOI: 10.5114/fn.2016.62233, Vol.54, No.3, pp.1-7, 2016
86. Jarząbek D.M., Chmielewski M., Dulnik J., Strojny-Nęda A., The Influence of the Particle Size on the Adhesion Between Ceramic Particles and Metal Matrix in MMC Composites, Journal of Materials Engineering and Performance, ISSN: 1059-9495, DOI: 10.1007/s11665-016-2107-3, Vol.25, No.8, pp.3139-3145, 2016
87. Latko P., Kołbuk D., Kozera R., Boczkowska A., Microstructural Characterization and Mechanical Properties of PA11 Nanocomposite Fibers, Journal of Materials Engineering and Performance, ISSN: 1059-9495, DOI: 10.1007/s11665-015-1817-2, Vol.25, No.1, pp.68-75, 2016
88. Strojny-Nęda A., Pietrzak K., Węglewski W., The Influence of Al<sub>2</sub>O<sub>3</sub> Powder Morphology on the Properties of Cu-Al<sub>2</sub>O<sub>3</sub> Composites Designed for Functionally Graded Materials (FGM), Journal of Materials Engineering and Performance, ISSN: 1059-9495, DOI: 10.1007/s11665-016-2204-3, Vol.25, No.8, pp.3173-3184, 2016
89. Kowalczyk P., Parametric constitutive model of plain-weave fabric reinforced composite ply, Advanced Composite Materials, ISSN: 0924-3046, DOI: 10.1080/09243046.2014.996959, Vol.25, No.3, pp.287-303, 2016
90. Enayati M.S., Behzad T., Sajkiewicz P., Bagheri R., Ghasemi-Mobarakeh L., Kuśnieruk S., Rogowska-Tylman J., Pahlevanneshan Z., Choińska E., Świąszkowski W., Fabrication and characterization of electrospun bionanocomposites of poly (vinyl alcohol)/ nanohydroxyapatite/cellulose nanofibers, International Journal of Polymeric Materials and Polymeric Biomaterials, ISSN: 0091-4037, DOI: 10.1080/00914037.2016.1157798, Vol.65, No.13, pp.660-674, 2016
91. Kúdela Jr S., Švec P., Bajana O., Orovčík L., Ranachowski P., Ranachowski Z., Strengthening in dual-phase structured Mg-Li-Zn alloys, KOVOVE MATERIALLY-METALLIC MATERIALS, ISSN: 0023-432X, DOI: 10.4149/km\_2016\_6\_483, Vol.54, pp.483-489, 2016
92. Mikułowski G., Wiszowaty R., Pneumatic Adaptive Absorber: Mathematical Modelling with Experimental Verification, MATHEMATICAL PROBLEMS IN ENGINEERING, ISSN: 1024-123X, DOI: 10.1155/2016/7074206, Vol.2016, pp.7074206-1-14, 2016
93. Holnicki-Szulc J., Ichchou M., Duan Z., Jankowski Ł., Adaptive Impact Absorption, MATHEMATICAL PROBLEMS IN ENGINEERING, ISSN: 1024-123X, DOI: 10.1155/2016/4871549, Vol.2016, pp.4871549-1-2, 2016
94. Pisarski D., Szmied T., Bajer C.I., Dyniewicz B., Bajkowski J.M., Vibration Control of Double-Beam System with Multiple Smart Damping Members, SHOCK AND VIBRATION, ISSN: 1070-9622, DOI: 10.1155/2016/2438902, Vol.2016, pp.2438902-1-14, 2016



95. Mróz K.P., Kucharski S., Doliński K., Bigos A., Mikułowski G., Beltowska-Lehman E., Nolbrzak P., Failure modes of coatings on steel substrate, BULLETIN OF THE POLISH ACADEMY OF SCIENCES: TECHNICAL SCIENCES, ISSN: 0239-7528, DOI: 10.1515/bpasts-2016-0027, Vol.64, No.1, pp.249-256, 2016
96. Świątek Z., Gradyś A., Maj Ł., Morgiel J., Marszałek K.W., Mania R., Szlezzynger M., XRD and TEM in situ Heating of Large Period Ni/Al Multilayer Coatings, ACTA PHYSICA POLONICA A, ISSN: 0587-4246, DOI: 10.12693/APhysPolA.130.880, Vol.130, No.4, pp.880-883, 2016
97. Gambin B., Byra M., Kruglenko E., Doubrovina O., Nowicki A., Ultrasonic Measurement of Temperature Rise in Breast Cyst and in Neighbouring Tissues as a Method of Tissue Differentiation, ARCHIVES OF ACOUSTICS, ISSN: 0137-5075, DOI: 10.1515/aoa-2016-0076, Vol.41, No.4, pp.791-798, 2016
98. Lewandowski M., Walczak M., Karwat P., Witek B., Karłowicz P., Research and Medical Transcranial Doppler System, ARCHIVES OF ACOUSTICS, ISSN: 0137-5075, DOI: 10.1515/aoa-2016-0074, Vol.41, No.4, pp.773-781, 2016
99. Meissner M., Prediction of Reverberant Properties of Enclosures via a Method Employing a Modal Representation of the Room Impulse Response, ARCHIVES OF ACOUSTICS, ISSN: 0137-5075, DOI: 10.1515/aoa-2016-0003, Vol.41, No.1, pp.27-41, 2016
100. Brandt A.M., O wpływie promieniowania jonizującego na beton, przegląd stanu wiedzy, CEMENT, WAPNO, BETON, ISSN: 1425-8129, Vol.6, pp.423-438, 2016
101. Baran T., Glinicki M.A., Józwiak-Niedźwiedzka D., The properties of special cements for shielding constructions in nuclear power plants/Właściwości cementów specjalnych przeznaczonych do betonu w konstrukcjach osłonowych elektrowni jądrowych, CEMENT, WAPNO, BETON, ISSN: 1425-8129, Vol.21, No.4, pp.207-216, 2016

### PAPERS IN OTHER JOURNALS, 2016

1. Suwała G., Knap L., Holnicki-Szulc J., Prestressing for Reduction of Local Vibrations in a Rotorcraft, ENGINEERING TRANSACTIONS (ROZPRAWY INŻYNIERSKIE), ISSN: 0867-888X, Vol.64, No.3, pp.367-380, 2016
2. Postek E., Sadowski T., Cracks in Interfaces and Around Their Junctions in WC/Co Composite, ENGINEERING TRANSACTIONS (ROZPRAWY INŻYNIERSKIE), ISSN: 0867-888X, Vol.64, No.4, pp.589-596, 2016
3. Papliński P., Ranachowski P., Mikrostruktura i stopień degradacji warstworów ZnO z eksploatacji w badaniach mikroskopowych, PRZEGLĄD ELEKTROTECHNICZNY, ISSN: 0033-2097, DOI: 10.15199/48.2016.10.29, Vol.92, No.10, pp.120-125, 2016
4. Wasilewski M., Pisarski D., Bajer C.I., Adaptive stabilization of partially damaged vibrating structures, Machine Dynamics Research, ISSN: 2080-9948, Vol.40, No.1, pp.65-82, 2016
5. Kukła D., Grzywna P., Kopeć M., Kowalewski Z.L., Assessment of hardened layer thickness for 40HnMA steel using eddy current method, INŻYNIERIA MATERIAŁOWA, ISSN: 0208-6247, DOI: 10.15199/28.2016.5.10, Vol.213, No.5, pp.263-266, 2016
6. Kopeć M., Grzywna P., Kukła D., Kowalewski Z.L., Evaluation of the fatigue damage development using ESPI method, INŻYNIERIA MATERIAŁOWA, ISSN: 0208-6247, DOI: 10.15199/28.2016.4.9, Vol.212, No.4, pp.201-205, 2016
7. Glinicki M.A., Jaskulski R., Dąbrowski M., Design principles and testing of internal frost resistance of concrete for road structures – critical review, Roads and Bridges - Drogi i Mosty, ISSN: 1643-1618, DOI: 10.7409/rabdim.016.002, Vol.15, No.1, pp.21-43, 2016
8. Widłaszewski J., Dwukierunkowe mikrogięcie laserowe dla układów MOEMS, MECHANIK, ISSN: 0025-6552, DOI: 10.17814/mechanik.2016.12.572, Vol.89, No.12, pp.1824-1830, 2016
9. Kleiber M., Quo Vadis, Europa?, Przyszłość. Świat - Europa - Polska, ISSN: 1895-0949, Vol.1, No.33, pp.103-107, 2016
10. Nowicki A., Dobruch-Sobczak K., Introduction to ultrasound elastography, Journal of Ultrasonography, ISSN: 2084-8404, DOI: 10.15557/JoU.2016.0013, Vol.16, pp.113-124, 2016
11. Dębowski T., Lewandowski M., Mackiewicz S., Ranachowski Z., Schabowicz K., Badania ultradźwiękowe płyt włóknisto-cementowych, PRZEGLĄD SPAWALNICTWA, ISSN: 0033-2364, Vol.88, No.10, pp.69-71, 2016
12. Mackiewicz S., Podstawowe parametry głowic ultradźwiękowych oraz ich wpływ na jakość wykonywanych badań, PRZEGLĄD SPAWALNICTWA, ISSN: 0033-2364, Vol.88, No.10, pp.86-91, 2016
13. Lewandowski M., Walczak M., Steifer T., Zastosowanie metody pełnej akwizycji macierzy do wizualizacji wad w technice UT Phased-Array, PRZEGLĄD SPAWALNICTWA, ISSN: 0033-2364, Vol.88, No.10, pp.43-45, 2016
14. Kukła D., Piotrowski L., Szwed M., Ocena twardości warstw nawęglanych i hartowanych indukcyjnie na stali AMS 6414 z zastosowaniem magnetycznych technik nieniszczących, PRZEGLĄD SPAWALNICTWA, ISSN: 0033-2364, Vol.88, No.10, pp.46-50, 2016
15. Józwiak-Niedźwiedzka D., Brandt A., Gibas K., Ocena możliwości wystąpienia reakcji alkalicznej w betonach osłonowych z kruszywami specjalnymi, Journal of Civil Engineering, Environment and Architecture, ISSN: 2300-5130, DOI: 10.7862/rb.2016.15, Vol.XXXIII, No.63 (1/I/2016), pp.133-140, 2016
16. Dąbrowski M., Gibas K., Brandt A.M., Glinicki M.A., Wpływ kruszyw specjalnych na porowatość i przepuszczalność betonów osłonowych, Journal of Civil Engineering, Environment and Architecture, ISSN: 2300-5130, DOI: 10.7862/rb.2016.11, Vol.XXXIII, No.63 (1/I/2016), pp.97-106, 2016
17. Jaskulski R., Glinicki M.A., Dąbrowski M., Ranachowski Z., Sobczak M., Monitorowanie parametrów termicznych procesu twardnienia betonów osłonowych, Journal of Civil Engineering, Environment and Architecture, ISSN: 2300-5130, DOI: 10.7862/rb.2016.14, Vol.XXXIII, No.63 (1/I/2016), pp.123-132, 2016
18. Sarzyński A., Radziejewska J., Marczak J., Strzelec M., Ostrowski R., Rycyk A., Czyż K., Laserowa mikroobrobka materiałów, ELEKTRONIKA - KONSTRUKCJE, TECHNOLOGIE, ZASTOSOWANIA, ISSN: 0033-2089, DOI: 10.15199/13.2016.11.9, Vol.57, No.11, pp.42-47, 2016

19. Jeznach O., Gajc M., Kłos A., Orliński K., Pawlak D.A., Krok-Borkowicz M., Rumian Ł., Pietryga K., Reczyńska K., Pamuła E., The effect of titanium dioxide addition on physical and biological properties of Na<sub>2</sub>O-B<sub>2</sub>O<sub>3</sub>-P<sub>2</sub>O<sub>5</sub> and CaO-Na<sub>2</sub>O-P<sub>2</sub>O<sub>5</sub> glasses, ENGINEERING OF BIOMATERIALS / INŻYNIERIA BIOMATERIAŁÓW, ISSN: 1429-7248, Vol.19, No.134, pp.2-7, 2016
20. Jurczak K., Rojek J., Nosewicz S., Lumelsky D., Bochenek K., Chmielewski M., Pietrzak K., Modelowanie wstępnego prasowania proszków metodą elementów dyskretnych, HUTNIK - WIADOMOŚCI HUTNICZE, ISSN: 1230-3534, DOI: 10.15199/24.2016.1.1, Vol.83, No.1, pp.3-7, 2016
21. Żurek Z.H., Dobmann G., Rockstroh B., Kukła D., Diagnostyka eksploatacyjna stali w energetyce, ZESZYTY PROBLEMOWE - MASZYNY ELEKTRYCZNE, ISSN: 0239-3646, Vol.109, No.1, pp.169-176, 2016
22. Gambin B., Kruglenko E., Byra M., Relationships between Acoustical Properties and Stiffness of Soft Tissue Phantoms, HYDROACOUSTICS, ISSN: 1642-1817, Vol.19, pp.111-120, 2016
23. Gambin B., Wójcik J., Doubrovina O., Differentiation of random structure properties using wavelet analysis of backscattered ultrasound, HYDROACOUSTICS, ISSN: 1642-1817, Vol.19, pp.121-128, 2016
24. Karwat P., Kujawska T., Secomski W., Gambin B., Litniewski J., Application of ultrasound to noninvasive imaging of temperature distribution induced in tissue, HYDROACOUSTICS, ISSN: 1642-1817, Vol.19, pp.219-228, 2016
25. Nowicki A., Secomski W., Trawiński Z., Lewandowski M., Trots I., Szubielski M., Olszewski R., Estimation of radial artery reactive response using high frequency ultrasound, HYDROACOUSTICS, ISSN: 1642-1817, Vol.19, pp.297-306, 2016
26. Piotrkowska-Wroblewska H., Dobruch-Sobczak K., Litniewski J., Chrapowicki E., Roszkowska-Purska K., Nowicki A., Differentiation of the breast lesions using statistics of backscattered echoes, HYDROACOUSTICS, ISSN: 1642-1817, Vol.19, pp.319-328, 2016
27. Secomski W., Nowicki A., Generation and measurement of acoustic streaming in limited space, HYDROACOUSTICS, ISSN: 1642-1817, Vol.19, pp.361-368, 2016
28. Wójcik J., Byra M., Nowicki A., A spectral-based method for tissue characterization, HYDROACOUSTICS, ISSN: 1642-1817, Vol.19, pp.369-375, 2016
29. Johansen K., Postema M., Lagrangian formalism for computing oscillations of spherically symmetric encapsulated acoustic antibubbles, HYDROACOUSTICS, ISSN: 1642-1817, Vol.19, pp.197-208, 2016
30. Adamski G., Garbacik A., Glinicki M.A., Reaktywność alkaliczna krajowych kruszyw - założenia i cele projektu ASR-RID, PRZEGLĄD BUDOWLANY, ISSN: 0033-2038, Vol.87, No.5, pp.19-21, 2016
31. Szymczak T., Kowalewski Z.L., Brodecki A., Metoda cyfrowej korelacji obrazu w badaniach materiałów i elementów, Dozór Techniczny, ISSN: 0209-1763, Vol.4, pp.22-31, 2016
32. Konowrocki R., Szolc T., An analysis of the self-excited torsional vibrations of the electromechanical drive system, VIBRATIONS IN PHYSICAL SYSTEMS, ISSN: 0860-6897, Vol.27, pp.187-194, 2016
33. Michajłow M., Konowrocki R., Szolc T., A semi-active control of lateral vibrations of the overhung rotor using dampers with the magneto-rheological fluid, VIBRATIONS IN PHYSICAL SYSTEMS, ISSN: 0860-6897, Vol.27, pp.274-280, 2016
34. Makowska K., Kowalewski Z.L., Ocena stopnia degradacji materiałów ferromagnetycznych technikami magnetycznymi, ENERGETYKA, PROBLEMY ENERGETYKI I GOSPODARKI PALIWOWO-ENERGETYCZNEJ, ISSN: 0013-7294, Vol.749, No.11, pp.681-684, 2016

### CONFERENCE PROCEEDINGS INDEXED IN WEB OF SCIENCE, 2016

1. Białek Ł., Szklarski J., Borkowska M.M., Gnatowski M., Reasoning with Four-Valued Logic in Multi-robotic Search-and-Rescue Problem, AUTOMATION-2016, Challenges in Automation, Robotics and Measurement Techniques, 2016-03-02/03-04, Warszawa (PL), DOI: 10.1007/978-3-319-29357-8, Vol.440, pp.483-499, 2016
2. Hołobut P., Chodkiewicz P., Macios A., Lengiewicz J., Internal localization algorithm based on relative positions for cubic-lattice modular-robotic ensembles, IROS, IROS 2016 - IEEE/RSJ International Conference on Intelligent Robots and Systems, 2016-10-09/10-14, Daejeon, South Korea (KP), DOI: 10.1109/IROS.2016.7759473, pp.3056-3062, 2016
3. Błachowski B., Hołobut P., Ortiz A., Caicedo J.M., Simple human-structure interaction model of walking on a flexible surface, ISMA 2016 / USD 2016, International Conference on Noise and Vibration Engineering / International Conference on Uncertainty in Structural Dynamics, 2016-09-19/09-21, Leuven (BE), pp.559-570, 2016
4. Błachowski B., An Y., Spencer Jr. B.F., Substructure-level based method for damage quantification in determinant trusses, ISMA 2016 / USD 2016, International Conference on Noise and Vibration Engineering / International Conference on Uncertainty in Structural Dynamics, 2016-09-19/09-21, Leuven (BE), pp.3283-3294, 2016
5. Zieliński T.G., Pore-size effects in sound absorbing foams with periodic microstructure: modelling and experimental verification using 3D printed specimens, ISMA 2016 / USD 2016, International Conference on Noise and Vibration Engineering / International Conference on Uncertainty in Structural Dynamics, 2016-09-19/09-21, Leuven (BE), pp.95-104, 2016
6. Lewandowski M., Walczak M., Witek B., Steifer T., A GPU-based Ultrasound Phased-Array Research System for Non-destructive Testing, IUS 2016, IEEE International Ultrasonics Symposium, 2016-09-18/09-21, Tours (FR), DOI: 10.1109/ULTSYM.2016.7728843, pp.1-4, 2016
7. Kustroń P., Korzeniowski M., Lewandowski M., Witek B., Rozbicki J., A High Frequency Ultrasonic Imaging of Welded Joints, IUS 2016, IEEE International Ultrasonics Symposium, 2016-09-18/09-21, Tours (FR), DOI: 10.1109/ULTSYM.2016.7728848, pp.1-4, 2016
8. Steifer T., Klimonda Z., Lewandowski M., Multiply and Sum Spatial Compounding in Plane Wave Imaging, IUS 2016, IEEE International Ultrasonics Symposium, 2016-09-18/09-21, Tours (FR), DOI: 10.1109/ULTSYM.2016.7728887, pp.1-3, 2016

9. Kielczyński P, Szalewski M, Balcerzak A, Wieja K, Evaluation of viscoelastic parameters of surface layers by ultrasonic Love waves, IUS 2016, IEEE International Ultrasonics Symposium, 2016-09-18/09-21, Tours (FR), DOI: 10.1109/ULTSYM.2016.7728446, pp.1-4, 2016
10. Kielczyński P, Szalewski M, Balcerzak A, Wieja K, Rostocki A.J., Ptasznik S., Investigation of high-pressure phase transitions in biofuels by means of ultrasonic methods, IUS 2016, IEEE International Ultrasonics Symposium, 2016-09-18/09-21, Tours (FR), DOI: 10.1109/ULTSYM.2016.7728444, pp.1-4, 2016
11. Golański K., Pieczyska E., Staszczak M., Maj M., Furuta T., Kuramoto S., Infrared thermography applied for experimental investigation of thermomechanical couplings in Gum Metal, QIRT 2016, XIII International Quantitative InfraRed Thermography Conference, 2016-06-04/06-08, Gdańsk (PL), DOI: 10.21611/qirt.2016.038, pp.291-296, 2016
12. Libura T., Kowalewski Z.L., Dietrich L., Socha G., Anti-buckling system for flat specimens investigations under cyclic tension-compression, Materials Today: Proceedings, ISSN: 2214-7853, DOI: 10.1016/j.matpr.2016.03.045, No.3, pp.1045-1050, 2016
13. Szymczak T., Kowalewski Z.L., Brodecki A., Determination of artificial defects in material under monotonic tension by the use of FEM and DIC methods, Materials Today: Proceedings, ISSN: 2214-7853, DOI: 10.1016/j.matpr.2016.03.011, No.3, pp.1171-1176, 2016
14. Mościcki T., Differences in Nanosecond Laser Ablation and Deposition of Tungsten, Boron, and WB2/B Composite due to Optical Properties, International Journal of Optics, ISSN: 1687-9384, DOI: 10.1155/2016/5438721, Vol.5438721, pp.5438721-1-13, 2016
15. Mucha Z., Widłaszewski J., Kurp P., Mulczyk K., Mechanically assisted laser forming of thin beams, Proceedings of SPIE, ISSN: 0277-786X, DOI: 10.1117/12.2262114, Vol.10159, pp.10159 0U-1-10159 0U-10, 2016

### PAPERS IN JOURNALS INDEXED IN WEB OF SCIENCE, 2017

1. Zawistowski T., Kleiber M., Gap Flow Simulation Methods in High Pressure Variable Displacement Axial Piston Pumps, ARCHIVES OF COMPUTATIONAL METHODS IN ENGINEERING, ISSN: 1134-3060, DOI: 10.1007/s11831-016-9180-5, Vol.24, No.3, pp.519-542, 2017
2. Dziekoński C., Dera W., Jarząbek D.M., Method for lateral force calibration in atomic force microscope using MEMS microforce sensor, ULTRAMICROSCOPY, ISSN: 0304-3991, DOI: 10.1016/j.ultramic.2017.06.012, Vol.182, pp.1-9, 2017
3. Kochańczyk M., Hlavacek W.S., Lipniacki T., SPATKIN: a simulator for rule-based modelling of biomolecular site dynamics on surfaces, BIOINFORMATICS, ISSN: 1367-4803, DOI: 10.1093/bioinformatics/btx456, Vol.33, No.22, pp.3667-3669, 2017
4. Taczala M., Buczkowski R., Kleiber M., Nonlinear buckling and post-buckling response of stiffened FGM plates in thermal environments, COMPOSITES PART B-ENGINEERING, ISSN: 1359-8368, DOI: 10.1016/j.compositesb.2016.09.023, Vol.109, pp.238-247, 2017
5. Majewski M., Kurska M., Hołobut P., Kowalczyk-Gajewska K., Micromechanical and numerical analysis of packing and size effects in elastic particulate composites, COMPOSITES PART B-ENGINEERING, ISSN: 1359-8368, DOI: 10.1016/j.compositesb.2017.05.004, Vol.124, pp.158-174, 2017
6. Sadowski P., Kowalczyk-Gajewska K., Stupkiewicz S., Consistent treatment and automation of the incremental Mori-Tanaka scheme for elasto-plastic composites, COMPUTATIONAL MECHANICS, ISSN: 0178-7675, DOI: 10.1007/s00466-017-1418-z, Vol.60, pp.493-511, 2017
7. Wiśniewski K., Turska E., Improved nine-node shell element MITC9i with reduced distortion sensitivity, COMPUTATIONAL MECHANICS, ISSN: 0178-7675, DOI: 10.1007/s00466-017-1510-4, pp.1-25, 2017
8. Błachowski B., An Y., Spencer Jr. B.F., Ou J., Axial strain accelerations approach for damage localization in statically determinate truss structures, Computer-Aided Civil and Infrastructure Engineering, ISSN: 1093-9687, DOI: 10.1111/mice.12258, Vol.32, No.4, pp.304-318, 2017
9. Adimy M., Chekroun A., Kaźmierczak B., Traveling waves in a coupled reaction-diffusion and difference model of hematopoiesis, Journal of Differential Equations, ISSN: 0022-0396, DOI: 10.1016/j.jde.2016.12.009, Vol.262, No.7, pp.4085-4128, 2017
10. Pierini F., Lanzi M., Nakielski P., Pawłowska S., Urbanek O., Zembrzycki K., Kowalewski T.A., Single-Material Organic Solar Cells Based on Electrospun Fullerene-Grafted Polythiophene Nanofibers, Macromolecules, ISSN: 0024-9297, DOI: 10.1021/acs.macromol.7b00857, Vol.50, No.13, pp.4972-4981, 2017
11. Bobrowski A., Kaźmierczak B., Kunze M., An averaging principle for fast diffusions in domains separated by semi-permeable membranes, MATHEMATICAL MODELS AND METHODS IN APPLIED SCIENCES, ISSN: 0218-2025, DOI: 10.1142/S0218202517500130, Vol.27, No.4, pp.663-706, 2017
12. Suwała G., Jankowski Ł., Nonparametric identification of structural modifications in Laplace domain, MECHANICAL SYSTEMS AND SIGNAL PROCESSING, ISSN: 0888-3270, DOI: 10.1016/j.ymsp.2016.09.018, Vol.18, pp.867-878, 2017
13. Habibi I., Cheong R., Lipniacki T., Levchenko A., Emamian E.S., Abdi A., Computation and measurement of cell decision making errors using single cell data, PLOS COMPUTATIONAL BIOLOGY, ISSN: 1553-734X, DOI: 10.1371/journal.pcbi.1005436, Vol.13, No.4, pp.e1005436-1-17, 2017
14. Fras T., Murzyn A., Pawłowski P., Defeat mechanisms provided by slotted add-on bainitic plates against small-calibre 7.62 mm x 51 AP projectiles, INTERNATIONAL JOURNAL OF IMPACT ENGINEERING, ISSN: 0734-743X, DOI: 10.1016/j.ijimpeng.2017.01.015, Vol.103, pp.241-253, 2017
15. Moallemi S., Pietruszczak S., Mróz Z., Deterministic size effect in concrete structures with account for chemo-mechanical loading, COMPUTERS AND STRUCTURES, ISSN: 0045-7949, DOI: 10.1016/j.compstruc.2016.10.003, Vol.182, pp.74-86, 2017
16. Kubissa W., Glinicki M.A., Influence of internal relative humidity and mix design of radiation shielding concrete on air permeability index, CONSTRUCTION AND BUILDING MATERIALS, ISSN: 0950-0618, DOI: 10.1016/j.conbuildmat.2017.04.177, Vol.147, pp.352-361, 2017
17. Ranachowski Z., Schabowicz K., The contribution of fiber reinforcement system to the overall toughness of cellulose fiber concrete panels, CONSTRUCTION AND BUILDING MATERIALS, ISSN: 0950-0618, DOI: 10.1016/j.conbuildmat.2017.09.067, Vol.156, pp.1028-1034, 2017
18. Labra C., Rojek J., Oñate E., Discrete/Finite Element Modelling of Rock Cutting with a TBM Disc Cutter, Rock Mechanics and Rock Engineering, ISSN: 0723-2632, DOI: 10.1007/s00603-016-1133-7, Vol.50, pp.621-638, 2017

19. Kochańczyk M., Kocieniewski P., Kozłowska E., Jaruszewicz-Błońska J., Sparta B., Pargett M., Albeck J.G., Hlavacek W.S., Lipniacki T., Relaxation oscillations and hierarchy of feedbacks in MAPK signaling, Scientific Reports, ISSN: 2045-2322, DOI: 10.1038/srep38244, Vol.7, No.38244, pp.1-15, 2017
20. Tudelska K., Markiewicz J., Kochańczyk M., Czerkies M., Prus W., Korwek Z., Abdi A., Błoński S., Kaźmierczak B., Lipniacki T., Information processing in the NF- $\kappa$ B pathway, Scientific Reports, ISSN: 2045-2322, DOI: 10.1038/s41598-017-16166-y, Vol.7, pp.15926, 2017
21. Krajewski M., Lee P.H., Wu S.H., Brzózka K., Małolepszy A., Stobiński L., Tokarczyk M., Kowalski G., Wąsik D., Nanocomposite composed of multiwall carbon nanotubes covered by hematite nanoparticles as anode material for Li-ion batteries, Electrochimica Acta, ISSN: 0013-4686, DOI: 10.1016/j.electacta.2017.01.051, Vol.228, pp.82-90, 2017
22. Varga A., Ehrenreiter K., Aschenbrenner B., Kocieniewski P., Kochańczyk M., Lipniacki T., Baccarini M., RAF1/BRAF dimerization integrates the signal from RAS to ERK and ROK $\alpha$ , Science Signaling, ISSN: 1945-0877, DOI: 10.1126/scisignal.aai8482, Vol.10, No.469, pp.eaai8482-1-11, 2017
23. Banach Z., Larecki W., Entropy-based mixed three-moment description of fermionic radiation transport in slab and spherical geometries, Kinetic and Related Models, ISSN: 1937-5093, DOI: 10.3934/krm.2017035, Vol.10, No.4, pp.879-900, 2017
24. Krajewski M., Magnetic-field-induced synthesis of magnetic wire-like micro- and nanostructures, NANOSCALE, ISSN: 2040-3364, DOI: 10.1039/c7nr05823c, Vol.9, No.43, pp.16511-16545, 2017
25. Kowalewski P.K., Olszewski R., Wałędzia M.S., Janik M.R., Kwiatkowski A., Gałzka-Świderek N., Cichoń K., Brągoszewski J., Paśnik K., Long-Term Outcomes of Laparoscopic Sleeve Gastrectomy—a Single-Centre, Retrospective Study, Obesity Surgery, ISSN: 0960-8923, DOI: 10.1007/s11695-017-2795-2, pp.1-5, 2017
26. Żuk P.J., Cichocki B., Szymczak P., Intrinsic viscosity of macromolecules within the generalized Rotne-Prager-Yamakawa approximation, JOURNAL OF FLUID MECHANICS, ISSN: 0022-1120, DOI: 10.1017/jfm.2017.264, Vol.822, pp.R2-1-11, 2017
27. Ryś M., Skoczeń B., Coupled constitutive model of damage affected two-phase continuum, MECHANICS OF MATERIALS, ISSN: 0167-6636, DOI: 10.1016/j.mechmat.2017.08.015, Vol.115, pp.1-15, 2017
28. Jarząbek D.M., Milczarek M., Wojciechowski T., Dziekoński C., Chmielewski M., The effect of metal coatings on the interfacial bonding strength of ceramics to copper in sintered Cu-SiC composites, CERAMICS INTERNATIONAL, ISSN: 0272-8842, DOI: 10.1016/j.ceramint.2017.01.056, pp.1-9, 2017
29. Grady A., Geometrical effects during crystallization under confinement in electrospun core-shell fibers. DSC study of crystallization kinetics, POLYMER, ISSN: 0032-3861, DOI: 10.1016/j.polymer.2016.12.009, Vol.108, pp.383-394, 2017
30. Urbanek O., Sajkiewicz P., Pierini F., The effect of polarity in the electrospinning process on PCL/chitosan nanofibres' structure, properties and efficiency of surface modification, POLYMER, ISSN: 0032-3861, DOI: 10.1016/j.polymer.2017.07.064, Vol.124, pp.168-175, 2017
31. Pieczyska E.A., Staszczak M., Kowalczyk-Gajewska K., Maj M., Golański K., Golba S., Tobushi H., Hayashi S., Experimental and numerical investigation of yielding phenomena in a shape memory polymer subjected to cyclic tension at various strain rates, POLYMER TESTING, ISSN: 0142-9418, DOI: 10.1016/j.polymertesting.2017.04.014, Vol.60, pp.333-342, 2017
32. Pawłowska S., Nakielski P., Pierini F., Piechocka I.K., Zembrzycki K., Kowalewski T.A., Lateral migration of electrospun hydrogel nanofilaments in an oscillatory flow, PLOS ONE, ISSN: 1932-6203, DOI: 10.1371/journal.pone.0187815, Vol.12, No.11, pp.1-21, 2017
33. Bialecki S., Kaźmierczak B., Lipniacki T., Polarization of concave domains by traveling wave pinning, PLOS ONE, ISSN: 1932-6203, DOI: 10.1371/journal.pone.0190372, Vol.12, No.12, pp.e0190372-1-10, 2017
34. Wójcik J., Gambin B., Theoretical and numerical aspects of nonlinear reflection-transmission phenomena in acoustics, Applied Mathematical Modelling, ISSN: 0307-904X, DOI: 10.1016/j.apm.2016.10.026, Vol.42, pp.100-113, 2017
35. Graczykowski C., Pawłowski P., Exact physical model of magnetorheological damper, Applied Mathematical Modelling, ISSN: 0307-904X, DOI: 10.1016/j.apm.2017.02.035, Vol.47, pp.400-424, 2017
36. Piotrkowska-Wróblewska H., Dobruch-Sobczak K., Byra M., Nowicki A., Open access database of raw ultrasonic signals acquired from malignant and benign breast lesions, Medical Physics, ISSN: 0094-2405, DOI: 10.1002/mp.12538, Vol.44, No.9, pp.1-5, 2017
37. Korol E., Tejchman J., Mróz Z., Experimental and numerical assessment of size effect in geometrically similar slender concrete beams with basalt reinforcement, ENGINEERING STRUCTURES, ISSN: 0141-0296, DOI: 10.1016/j.engstruct.2017.03.011, Vol.141, pp.272-291, 2017
38. Kielczyński P., Szalewski M., Balcerzak A., Wieja K., Rostocki A., Ptasznik S., Evaluation of High-Pressure Thermophysical Parameters of the Diacylglycerol (DAG) Oil Using Ultrasonic Waves, Food and Bioprocess Technology, ISSN: 1935-5130, DOI: 10.1007/s11947-016-1827-6, Vol.10, No.2, pp.358-369, 2017
39. Jarecki L., Misztal-Faraj B., Non-linear stress-orientation behavior of flexible chain polymers under fast elongational flow, EUROPEAN POLYMER JOURNAL, ISSN: 0014-3057, DOI: 10.1016/j.eurpolymj.2017.08.028, Vol.95, pp.368-381, 2017
40. Lanzi M., Salatelli E., Giorgini L., Mucci A., Pierini F., Di-Nicola F.P., Water-soluble polythiophenes as efficient charge-transport layers for the improvement of photovoltaic performance in bulk heterojunction polymeric solar cells, EUROPEAN POLYMER JOURNAL, ISSN: 0014-3057, DOI: 10.1016/j.eurpolymj.2017.10.032, Vol.97, pp.378-388, 2017
41. Colabella L., Csilino A.P., Häit G., Kowalczyk P., Mimetization of the elastic properties of cancellous bone via a parameterized cellular material, Biomechanics and Modelling in Mechanobiology, ISSN: 1617-7959, DOI: 10.1007/s10237-017-0901-y, Vol.16, No.5, pp.1485-1502, 2017
42. Kielczyński P., Ptasznik S., Szalewski M., Balcerzak A., Wieja K., Rostocki A.J., Thermophysical properties of rapeseed oil methyl esters (RME) at high pressures and various temperatures evaluated by ultrasonic methods, Biomass and Bioenergy, ISSN: 0961-9534, DOI: 10.1016/j.biombioe.2017.09.015, Vol.107, pp.113-121, 2017
43. Petryk H., Stupkiewicz S., Kucharski S., On direct estimation of hardening exponent in crystal plasticity from the spherical indentation test, INTERNATIONAL JOURNAL OF SOLIDS AND STRUCTURES, ISSN: 0020-7683, DOI: 10.1016/j.ijsolstr.2016.09.025, Vol.112, pp.209-221, 2017
44. Sławianowski J.J., Kovalchuk V., Gołubowska B., Martens A., Rożko E.E., Mechanics of affine bodies. Towards affine dynamical symmetry, JOURNAL OF MATHEMATICAL ANALYSIS AND APPLICATIONS, ISSN: 0022-247X, DOI: 10.1016/j.jmaa.2016.08.042, Vol.446, pp.493-520, 2017

45. Piotrowski L., Chmielewski M., Kowalewski Z.L., The Dominant Influence of Plastic Deformation Induced Residual Stress on the Barkhausen Effect Signal in Martensitic Steels, JOURNAL OF NONDESTRUCTIVE EVALUATION, ISSN: 0195-9298, DOI: 10.1007/s10921-016-0389-x, Vol.36, No.10, pp.1-8, 2017
46. Makowska K., Piotrowski L., Kowalewski Z.L., Prediction of the Mechanical Properties of P91 Steel by Means of Magneto-acoustic Emission and Acoustic Birefringence, JOURNAL OF NONDESTRUCTIVE EVALUATION, ISSN: 0195-9298, DOI: 10.1007/s10921-017-0421-9, Vol.36, No.2, pp.43/1-43/10, 2017
47. Bajer C.I., Pisarski D., Szmidt T., Dyniewicz B., Intelligent damping layer under a plate subjected to a pair of masses moving in opposite directions, JOURNAL OF SOUND AND VIBRATION, ISSN: 0022-460X, DOI: 10.1016/j.jsv.2017.01.046, Vol.394, pp.333-347, 2017
48. Szmidt T., Pisarski D., Bajer C.I., Dyniewicz B., Double-beam cantilever structure with embedded intelligent damping block: Dynamics and control, JOURNAL OF SOUND AND VIBRATION, ISSN: 0022-460X, DOI: 10.1016/j.jsv.2017.04.033, Vol.401, pp.127-138, 2017
49. Zieliński T.G., Microstructure representations for sound absorbing fibrous media: 3D and 2D multiscale modelling and experiments, JOURNAL OF SOUND AND VIBRATION, ISSN: 0022-460X, DOI: 10.1016/j.jsv.2017.07.047, Vol.409, pp.112-130, 2017
50. Dyniewicz B., Pisarski D., Bajer C.I., Vibrations of a Mindlin plate subjected to a pair of inertial loads moving in opposite directions, JOURNAL OF SOUND AND VIBRATION, ISSN: 0022-460X, DOI: 10.1016/j.jsv.2016.09.027, Vol.386, pp.265-282, 2017
51. Pakdel A., Witecka A., Rydzek G., Shri D.N.A., A comprehensive microstructural analysis of Al-WC micro- and nano-composites prepared by spark plasma sintering, MATERIALS AND DESIGN, ISSN: 0261-3069, DOI: 10.1016/j.matdes.2017.01.064, Vol.119, pp.225-234, 2017
52. Chmielewski M., Pietrzak K., Teodorczyk M., Nosewicz S., Jarzabek D., Zybala R., Bazarnik P., Lewandowska M., Strojny-Nędzka A., Effect of metallic coating on the properties of copper-silicon carbide composites, APPLIED SURFACE SCIENCE, ISSN: 0169-4332, DOI: 10.1016/j.apsusc.2016.12.130, Vol.421, pp.159-169, 2017
53. Hoffman J., Chrzanowska J., Mościcki T., Radziejewska J., Stobiński L., Szymański Z., Plasma generated during underwater pulsed laser processing, APPLIED SURFACE SCIENCE, ISSN: 0169-4332, DOI: 10.1016/j.apsusc.2017.01.185, Vol.417, pp.130-135, 2017
54. Leyva-Mendivil M.F., Lengiewicz J., Page A., Bressloff N.W., Limbert G., Skin Microstructure is a Key Contributor to Its Friction Behaviour, TRIBOLOGY LETTERS, ISSN: 1023-8883, DOI: 10.1007/s11249-016-0794-4, Vol.65, No.12, pp.1-17, 2017
55. Giusti S.M., Mróz Z., Novotny A.A., Sokołowski J., Topology design of thermomechanical actuators, STRUCTURAL AND MULTIDISCIPLINARY OPTIMIZATION, ISSN: 1615-147X, DOI: 10.1007/s00158-016-1593-0, Vol.55, No.5, pp.1575-1587, 2017
56. An Y., Błachowski B., Zhong Y., Hołobut P., Ou J., Rank-revealing QR decomposition applied to damage localization in truss structures, STRUCTURAL CONTROL AND HEALTH MONITORING, ISSN: 1545-2255, DOI: 10.1002/stc.1849, Vol.24, No.2, pp.e1849-1-15, 2017
57. Průša V., Řehoř M., Tůma K., Colombeau algebra as a mathematical tool for investigating step load and step deformation of systems of nonlinear springs and dashpots, ZEITSCHRIFT FÜR ANGEWANDTE MATHEMATIK UND PHYSIK ZAMP, ISSN: 0044-2275, DOI: 10.1007/s00033-017-0768-x, Vol.68, No.24, pp.1-13, 2017
58. Banach Z., Larecki W., Kershaw-type transport equations for fermionic radiation, ZEITSCHRIFT FÜR ANGEWANDTE MATHEMATIK UND PHYSIK ZAMP, ISSN: 0044-2275, DOI: 10.1007/s00033-017-0847-z, Vol.68, No.4, pp.100-1-100-24, 2017
59. Zajączkowska U., Kucharski S., Nowak Z., Grabowska K., Morphometric and mechanical characteristics of Equisetum hyemale stem enhance its vibration, PLANTA, ISSN: 0032-0935, DOI: 10.1007/s00425-017-2648-1, Vol.245, No.4, pp.835-848, 2017
60. Jaruszewicz-Błorńska J., Lipniacki T., Genetic toggle switch controlled by bacterial growth rate, BMC SYSTEMS BIOLOGY, ISSN: 1752-0509, DOI: 10.1186/s12918-017-0483-4, Vol.11, pp.117-1-11, 2017
61. Nosewicz S., Rojek J., Chmielewski M., Pietrzak K., Discrete element modelling and experimental investigation of hot pressing of intermetallic NiAl powder, ADVANCED POWDER TECHNOLOGY, ISSN: 0921-8831, DOI: 10.1016/j.apt.2017.04.012, Vol.28, pp.1745-1759, 2017
62. Michajłow M., Jankowski Ł., Szolc T., Konowrocki R., Semi-active reduction of vibrations in the mechanical system driven by an electric motor, OPTIMAL CONTROL APPLICATIONS & METHODS, ISSN: 0143-2087, DOI: 10.1002/oca.2297, Vol.38, No.6, pp.922-933, 2017
63. Pisarski D., Myśliński A., Online adaptive algorithm for optimal control of structures subjected to travelling loads, OPTIMAL CONTROL APPLICATIONS & METHODS, ISSN: 0143-2087, DOI: 10.1002/oca.2321, Vol.38, No.6, pp.1168-1186, 2017
64. Urbanek O., Sajkiewicz P., Pierini F., Czerkies M., Kolbuk D., Structure and properties of polycaprolactone/chitosan nonwovens tailored by solvent systems, Biomedical Materials, ISSN: 1748-6041, DOI: 10.1088/1748-605X/aa5647, Vol.12, No.1, pp.015020-1-12, 2017
65. Jarzabek D.M., Gwiazda M., Dera W., The Influence of Alkali Metal Chloride Treatments on the Wear Resistance of Silicon Surfaces for Possible Use in MEMS, TRIBOLOGY TRANSACTIONS, ISSN: 1040-2004, DOI: 10.1080/10402004.2017.1296211, pp.1-7, 2017
66. Martincuks A., Andryka K., Küster A., Schmitz-Van de Leur H., Komorowski M., Müller-Newen G., Nuclear translocation of STAT3 and NF-κB are independent of each other but NF-κB supports expression and activation of STAT3, Cellular Signalling, ISSN: 0898-6568, DOI: 10.1016/j.cellsig.2017.01.006, Vol.32, pp.36-47, 2017
67. Nowak K.M., Nowak Ł.J., Experimental validation of the tuneable diaphragm effect in modern acoustic stethoscopes, Postgraduate Medical Journal, ISSN: 0032-5473, DOI: 10.1136/postgradmedj-2017-134810, pp.1-5, 2017
68. Nosewicz S., Rojek J., Chmielewski M., Pietrzak K., Lumelskyj D., Application of the Hertz formulation in the discrete element model of pressure-assisted sintering, GRANULAR MATTER, ISSN: 1434-5021, DOI: 10.1007/s10035-016-0699-9, Vol.19, No.1, pp.16-1-8, 2017
69. Orłowska A., Graczykowski C., Gałęzia A., The effect of prestress force magnitude on the natural bending frequencies of the eccentrically prestressed glass fibre reinforced polymer composite beams, Journal of Composite Materials, ISSN: 0021-9983, DOI: 10.1177/0021998317740202, pp.1-14, 2017
70. Pierini F., Lanzi M., Nakielski P., Kowalewski T.A., Electrospun Polyaniline-Based Composite Nanofibers: Tuning the Electrical Conductivity by Tailoring the Structure of Thiol-Protected Metal Nanoparticles, Journal of Nanomaterials, ISSN: 1687-4110, DOI: 10.1155/2017/6142140, Vol.2017, pp.1-10, 2017

71. Gluba-Brzózka A., Franczyk B., Olszewski R., Banach M., Rysz J., Personalized Medicine: New Perspectives for the Diagnosis and the Treatment of Renal Diseases, International Journal of Molecular Sciences, ISSN: 1422-0067, DOI: 10.3390/ijms18061248, Vol.18, No.1248, pp.1-20, 2017
72. Hron J., Miloš V., Průša V., Souček O., Tůma K., On thermodynamics of incompressible viscoelastic rate type fluids with temperature dependent material coefficients, INTERNATIONAL JOURNAL OF NON-LINEAR MECHANICS, ISSN: 0020-7462, DOI: 10.1016/j.ijnonlinmec.2017.06.011, Vol.95, pp.193-208, 2017
73. Lanzi M., Salatelli E., Di-Nicola F.P., Zuppiroli L., Pierini F., A new photocrosslinkable oligothiophene for organic solar cells with enhanced stability, MATERIALS CHEMISTRY AND PHYSICS, ISSN: 0254-0584, DOI: 10.1016/j.matchemphys.2016.10.034, Vol.186, pp.98-107, 2017
74. Maździarz M., Mrozek A., Kuś W., Burczyński T., First-principles study of new X-graphene and Y-graphene polymorphs generated by the two stage strategy, MATERIALS CHEMISTRY AND PHYSICS, ISSN: 0254-0584, DOI: 10.1016/j.matchemphys.2017.08.066, Vol.202, pp.7-14, 2017
75. Łazarska M., Woźniak T.Z., Ranachowski Z., Trafarski A., Domek G., Analysis of acoustic emission signals at austempering of steels using neural networks, METALS AND MATERIALS INTERNATIONAL, ISSN: 1598-9623, DOI: 10.1007/s12540-017-6347-z, pp.1-8, 2017
76. Meissner M., Acoustics of small rectangular rooms: Analytical and numerical determination of reverberation parameters, APPLIED ACOUSTICS, ISSN: 0003-682X, DOI: 10.1016/j.apacoust.2017.01.020, Vol.120, pp.111-119, 2017
77. Żolek N., Ranachowski Z., Ranachowski P., Józwiak-Niedźwiedzka D., Kúdelá Jr S., Dvorak T., Statistical assessment of the microstructure of barite aggregate from different deposits using x-ray microtomography and optical microscopy, ARCHIVES OF METALLURGY AND MATERIALS, ISSN: 1733-3490, DOI: 10.1515/amm-2017-0104, Vol.62, No.2, pp.697-702, 2017
78. Mackiewicz M., Mikulski J.L., Wańkowicz J., Kucharski S., Ranachowski P., Ranachowski Z., Study of composite insulator sheds subjected to wheel test, ARCHIVES OF METALLURGY AND MATERIALS, ISSN: 1733-3490, DOI: 10.1515/amm-2017-0101, Vol.62, No.2, pp.679-686, 2017
79. Łazarska M., Woźniak T.Z., Ranachowski Z., Ranachowski P., Trafarski A., The application of acoustic emission and artificial neural networks in an analysis of kinetics in the phase transformation of tool steel during austempering, ARCHIVES OF METALLURGY AND MATERIALS, ISSN: 1733-3490, DOI: 10.1515/amm-2017-0089, Vol.62, No.2, pp.603-609, 2017
80. Chmielewski M., Pietrzak K., Strojny-Nędzka A., Jarzabek D., Nosewicz S., Investigations of interface properties in copper-silicon carbide composites, ARCHIVES OF METALLURGY AND MATERIALS, ISSN: 1733-3490, DOI: 10.1515/amm-2017-0200, Vol.62, No.2B, pp.1315-1318, 2017
81. Strojny-Nędzka A., Pietrzak K., Teodorczyk M., Basista M., Węglewski W., Chmielewski M., Influence of Material Coating on the heat Transfer in a layered Cu-SiC-Cu Systems, ARCHIVES OF METALLURGY AND MATERIALS, ISSN: 1733-3490, DOI: 10.1515/amm-2017-0199, Vol.62, No.2B, pp.1311-1314, 2017
82. Wójcik J., Lewandowski M., Żolek N., Grating Lobes Suppression by Adding Virtual Receiving Subaperture in Synthetic Aperture Imaging, Ultrasonics, ISSN: 0041-624X, DOI: 10.1016/j.ultras.2016.12.013, Vol.76, pp.125-135, 2017
83. Kujawska T., Secomski W., Byra M., Postema M., Nowicki A., Annular phased array transducer for preclinical testing of anti-cancer drug efficacy on small animals, Ultrasonics, ISSN: 0041-624X, DOI: 10.1016/j.ultras.2016.12.008, Vol.76, pp.92-98, 2017
84. Secomski W., Bilmin K., Kujawska T., Nowicki A., Grieb P., Lewin P.A., In vitro ultrasound experiments: Standing wave and multiple reflections influence on the outcome, Ultrasonics, ISSN: 0041-624X, DOI: 10.1016/j.ultras.2017.02.008, Vol.77, pp.203-213, 2017
85. Trots I., Nowicki A., Postema M., Ultrasound Image Improvement by Code Bit Elongation, IEEE SIGNAL PROCESSING LETTERS, ISSN: 1070-9908, DOI: 10.1109/LSP.2017.2776040, pp.1-5, 2017
86. Mróz Z., Maciejewski J., Constitutive modelling of cyclic deformation of metals under strain controlled axial extension and cyclic torsion, ACTA MECHANICA, ISSN: 0001-5970, DOI: 10.1007/s00707-017-1982-5, pp.1-22, 2017
87. Kuśnierczyk K., Basista M., Recent advances in research on magnesium alloys and magnesium – calcium phosphate composites as biodegradable implant materials, JOURNAL OF BIOMATERIALS APPLICATIONS, ISSN: 0885-3282, DOI: 10.1177/0885328216657271, Vol.31, No.6, pp.878-900, 2017
88. Ziółkowski A., On consistent micromechanical estimation of macroscopic elastic energy, coherence energy and phase transformation strains for SMA materials, CONTINUUM MECHANICS AND THERMODYNAMICS, ISSN: 0935-1175, DOI: 10.1007/s00161-016-0530-1, Vol.29, No.1, pp.225-249, 2017
89. Basista M., Węglewski W., Bochenek K., Poniżnik Z., Nowak Z., Micro-CT Finite Element Analysis of Thermal Residual Stresses and Fracture in Metal-Ceramic Composites, Advanced Engineering Materials, ISSN: 1438-1656, DOI: 10.1002/adem.201600725, Vol.19, No.8, pp.1600725-1-9, 2017
90. Basista M., Jakubowska J., Węglewski W., Processing Induced Flaws in Aluminum–Alumina Interpenetrating Phase Composites, Advanced Engineering Materials, ISSN: 1438-1656, DOI: 10.1002/adem.201700484, Vol.19, No.1700484, pp.1-14, 2017
91. Golański K.M., Pieczyńska E.A., Staszczak M., Maj M., Furuta T., Kuramoto S., Infrared thermography applied for experimental investigation of thermomechanical couplings in Gum Metal, Quantitative InfraRed Thermography Journal, ISSN: 1768-6733, DOI: 10.1080/17686733.2017.1284295, Vol.14, No.2, pp.1-8, 2017
92. Dobruch-Sobczak K., Piotrkowska-Wróblewska H., Roszkowska-Purska K., Nowicki A., Jakubowski W., Usefulness of combined BI-RADS analysis and Nakagami statistics of ultrasound echoes in the diagnosis of breast lesions, Clinical Radiology, ISSN: 0009-9260, DOI: 10.1016/j.crad.2016.11.009, Vol.72, pp.339.e7-339.e15, 2017
93. Bajer C.I., Dyniewicz B., Shillor M., A Gao beam subjected to a moving inertial point load, Mathematics and Mechanics of Solids, ISSN: 1081-2865, DOI: 10.1177/1081286517718229, pp.1-12, 2017
94. Rojek J., Nosewicz S., Chmielewski M., Micro-macro relationships from discrete element simulations of sintering, INTERNATIONAL JOURNAL FOR MULTISCALE COMPUTATIONAL ENGINEERING, ISSN: 1543-1649, DOI: 10.1615/IntJMultCompEng.2017020322, Vol.15, No.4, pp.323-342, 2017
95. Maździarz M., Rojek J., Nosewicz S., Estimation of micromechanical NiAl sintering model parameters from the molecular simulations, INTERNATIONAL JOURNAL FOR MULTISCALE COMPUTATIONAL ENGINEERING, ISSN: 1543-1649, DOI: 10.1615/IntJMultCompEng.2017020289, Vol.15, No.4, pp.343-358, 2017

96. Pęcherski R.B., Nowak M., Nowak Z., Virtual metallic foams. Application for dynamic crushing analysis, INTERNATIONAL JOURNAL FOR MULTISCALE COMPUTATIONAL ENGINEERING, ISSN: 1543-1649, Vol.15, No.5, pp.431-442, 2017
97. Mrozek A., Kuś W., Burczyński T., Method for determining structures of new carbon-based 2D materials with predefined mechanical properties, INTERNATIONAL JOURNAL FOR MULTISCALE COMPUTATIONAL ENGINEERING, ISSN: 1543-1649, Vol.15, No.5, pp.379-394, 2017
98. Moćko W., Radziejewska J., Sarzyński A., Strzelec M., Marczak J., Analysis of the plastic deformation of AISI 304 steel induced by the nanosecond laser pulse, OPTICS & LASER TECHNOLOGY, ISSN: 0030-3992, DOI: 10.1016/j.optlastec.2016.11.022, Vol.90, pp.165-173, 2017
99. Poniżnik Z., Nowak Z., Basista M., Numerical modelling of deformation and fracture of reinforcing fibers in ceramic-metal composites, INTERNATIONAL JOURNAL OF DAMAGE MECHANICS, ISSN: 1056-7895, DOI: 10.1177/1056789515611945, Vol.26, No.5, pp.711-734, 2017
100. Wilczek M.M., Olszewski R., Krupienicz A., Trans -Fatty Acids and Cardiovascular Disease: Urgent Need for Legislation, CARDIOLOGY, ISSN: 0008-6312, DOI: 10.1159/000479956, Vol.138, No.4, pp.254-258, 2017
101. Mayerberger E.A., Urbanek O., McDaniel R.M., Street R.M., Barsoum M.W., Schauer C.L., Preparation and characterization of polymer-Ti3C2Tx(MXene) composite nanofibers produced via electrospinning, JOURNAL OF APPLIED POLYMER SCIENCE, ISSN: 0021-8995, DOI: 10.1002/app.45295, Vol.134, No.37, pp.45295-1-7, 2017
102. Nowak Ł.J., Nowak K.M., Acoustic characterization of stethoscopes using auscultation sounds as test signals, JOURNAL OF THE ACOUSTICAL SOCIETY OF AMERICA, ISSN: 0001-4966, DOI: 10.1121/1.4978524, Vol.141, No.3, pp.1940-1946, 2017
103. Balcerzak A., Comparison of High-Pressure Behavior of Physicochemical Properties of the Di- and Triacylglycerols Established by Ultrasonic Methods, JOURNAL OF THE AMERICAN OIL CHEMISTS SOCIETY, ISSN: 0003-021X, DOI: 10.1007/s11746-017-3030-y, Vol.94, No.10, pp.1261-1268, 2017
104. Ignaczak J., Domański W., An asymptotic approach to one-dimensional model of nonlinear thermoelasticity at low temperatures and small strains, JOURNAL OF THERMAL STRESSES, ISSN: 0149-5739, DOI: 10.1080/01495739.2016.1276872, pp.1-10, 2017
105. Białecki S., Kaźmierczak B., Nowicka D., Tsai J.-C., Regularity of solutions to a reaction-diffusion equation on the sphere: the Legendre series approach, MATHEMATICAL METHODS IN THE APPLIED SCIENCES, ISSN: 0170-4214, DOI: 10.1002/mma.4390, Vol.40, No.14, pp.5349-5369, 2017
106. Ślawianowski J.J., Kovalchuk V., Gołubowska B., Martens A., Rożko E.E., Quantized mechanics of affinely-rigid bodies, MATHEMATICAL METHODS IN THE APPLIED SCIENCES, ISSN: 0170-4214, DOI: 10.1002/mma.4501, Vol.40, No.18, pp.6900-6918, 2017
107. Sadowski P., Kowalczyk-Gajewska K., Stupkiewicz S., Response discontinuities in the solution of the incremental Mori-Tanaka scheme for elasto-plastic composites, ARCHIVES OF MECHANICS, ISSN: 0373-2029, Vol.69, No.1, pp.3-27, 2017
108. Takeda K., Matsui R., Tobushi H., Pieczyska E.A., Torsional deformation properties of SMA tapes and their application to bias-type reciprocating rotary driving actuator, ARCHIVES OF MECHANICS, ISSN: 0373-2029, Vol.69, No.4-5, pp.289-303, 2017
109. Cichocki B., Ekiel-Jeżewska M.L., Wajnryb E., Translational and rotational Brownian displacements of colloidal particles of complex shapes, ARCHIVES OF MECHANICS, ISSN: 0373-2029, Vol.69, No.3, pp.257-267, 2017
110. Chmielewski M., Pietrzak K., Strojny-Nędza A., Kaszyca K., Zybala R., Bazarnik P., Lewandowska M., Nosewicz S., Microstructure and thermal properties of Cu-SiC composite materials depending on the sintering technique, SCIENCE OF SINTERING, ISSN: 0350-820X, DOI: 10.2298/SOS1701011C, Vol.49, pp.11-22, 2017
111. Kukla D., Bryn T., Pakiela Z., Assessment of Fatigue Resistance of Aluminum Layers on MAR 247 Nickel Super Alloy with Full-Field Optical Strain Measurements, Journal of Materials Engineering and Performance, ISSN: 1059-9495, DOI: 10.1007/s11665-017-2767-7, pp.1-12, 2017
112. Lengiewicz J., Kurska M., Holobut P., Modular-robotic structures for scalable collective actuation, ROBOTICA, ISSN: 0263-5747, DOI: 10.1017/S026357471500082X, Vol.35, No.4, pp.787-808, 2017
113. Pamin J., Wcisło B., Kowalczyk-Gajewska K., Gradient-enhanced large strain thermoplasticity with automatic linearization and localization simulations, JOURNAL OF MECHANICS OF MATERIALS AND STRUCTURES, ISSN: 1559-3959, DOI: 10.2140/jomms.2017.12.123, Vol.12, No.1, pp.123-146, 2017
114. Nowak Z., Nowak M., Pęcherski R., Potoczek M., Śliwa R.E., Numerical Simulations of Mechanical Properties of Alumina Foams Based on Computed Tomography, JOURNAL OF MECHANICS OF MATERIALS AND STRUCTURES, ISSN: 1559-3959, DOI: 10.2140/jomms.2017.12.107, Vol.12, No.1, pp.107-121, 2017
115. Chwojnowski A., Kruk A., Wojciechowski C., Łukowska E., Dulnik J., Sajkiewicz P., The dependence of the membrane structure on the non-woven forming the macropores in the 3D scaffolds preparation, Desalination and Water Treatment, ISSN: 1944-3994, DOI: 10.5004/dwt.2017.11394, Vol.64, pp.324-331, 2017
116. Kruk A., Gadomska-Gajadur A., Ruśkowski P., Chwojnowski A., Dulnik J., Synoradzki L., Preparation of biodegradable semi-permeable membranes as 3D scaffolds for cell cultures, Desalination and Water Treatment, ISSN: 1944-3994, DOI: 10.5004/dwt.2017.11415, Vol.64, pp.317-323, 2017
117. Roszkiewicz A., Nasalski W., Transmission and reflection properties of two-dimensional finite metal crystals, EUROPEAN PHYSICAL JOURNAL D, ISSN: 1434-6060, DOI: 10.1140/epjd/e2017-70706-9, Vol.71, No.182, pp.1-12, 2017
118. Colabella L., Ibarra Pino A.A., Ballarre J., Kowalczyk P., Cisilino A.P., Calculation of cancellous bone elastic properties with the polarization-based FFT iterative scheme, International Journal for Numerical Methods in Biomedical Engineering, ISSN: 2040-7939, DOI: 10.1002/cnm.2879, Vol.33, No.11, pp.e2879-1-16, 2017
119. Kúdelá Jr S., Švec P., Bajana O., Orovčík L., Ranachowski P., Ranachowski Z., Saffil alumina fibers reinforced dual-phase Mg-Li and Mg-Li-Zn alloys, KOVOVE MATERIALY-METALLIC MATERIALS, ISSN: 0023-432X, DOI: 10.4149/km\_2017\_3\_195, Vol.55, pp.195-203, 2017
120. Zhang Q., Jankowski Ł., Damage identification using structural modes based on substructure virtual distortion method, ADVANCES IN STRUCTURAL ENGINEERING, ISSN: 1369-4332, DOI: 10.1177/1369433216660018, Vol.20, No.2, pp.257-271, 2017
121. Byra M., Kruglenko E., Gambin B., Nowicki A., Temperature Monitoring during Focused Ultrasound Treatment by Means of the Homodyned K Distribution, ACTA PHYSICA POLONICA A, ISSN: 0587-4246, DOI: 10.12693/APhysPolA.131.1525, Vol.131, No.6, pp.1525-1528, 2017

122. Levitant Zayonts N., Kwiatkowski L., Swiatek Z., Brzozowska J., Local Pseudoelastic Behaviour and Surface Characteristics of Ni Ion Implanted NiTi Shape Memory Alloy, ACTA PHYSICA POLONICA A, ISSN: 0587-4246, DOI: 10.12693/APhysPolA.132.210, Vol.132, No.2, pp.210-216, 2017
123. Jundziłł A., Pokrywczyna M., Adamowicz J., Kowalczyk T., Nowacki M., Bodnar M., Marszałek A., Frontczak-Baniewicz M.M., Mikułowski G., Kloskowski T., Gatherwright J., Drewa T., Vascularization Potential of Electrospun Poly(L-Lactide-co-Caprolactone) Scaffold: The Impact for Tissue Engineering, Medical Science Monitor, ISSN: 1643-3750, DOI: 10.12659/MSM.899659, Vol.23, pp.1540-1551, 2017
124. Błachowski B.D., Tazowski P., Lógó J., Modal Approximation Based Optimal Design of Dynamically Loaded Plastic Structures, Periodica Polytechnica Civil Engineering, ISSN: 0553-6626, DOI: 10.3311/PPci.11016, pp.1-6, 2017
125. Tazowski P., Lógó J., Pintér E., Parametric Study on the Element Size Effect for Optimal Topologies, Periodica Polytechnica Civil Engineering, ISSN: 0553-6626, DOI: 10.3311/PPci.0000, pp.1-10, 2017
126. Banak R., Mościcki T., Tofil S., Hoffman J., Antoszewski B., Laser Welding of a Spark Plug Electrode: Modelling the Problem of Metals with Disparate Melting Points, LASERS in ENGINEERING, ISSN: 0898-1507, Vol.38, No.3-6, pp.267-281, 2017
127. Będkowski J., Röhling T., Online 3D LIDAR Monte Carlo localization with GPU acceleration, Industrial Robot: An International Journal, ISSN: 0143-991X, DOI: 10.1108/IR-11-2016-0309, Vol.44, No.4, pp.442-456, 2017
128. Johansen K., Kimmel E., Postema M., Theory of Red Blood Cell Oscillations in an Ultrasound Field, ARCHIVES OF ACOUSTICS, ISSN: 0137-5075, DOI: 10.1515/aoa-2017-0013, Vol.42, No.1, pp.121-126, 2017
129. Glinicki M.A., Dąbrowski M., Skrzypczyński M., Influence of curing on the properties of air-entrained concrete in the upper layer of exposed aggregate pavement-modelling study, CEMENT, WAPNO, BETON, ISSN: 1425-8129, Vol.XXII/LXXXIV, No.4, pp.271-281, 2017
130. Ustrzycka A., Mróz Z., Kowalewski Z.L., Experimental analysis and modelling of fatigue crack initiation mechanisms, JOURNAL OF THEORETICAL AND APPLIED MECHANICS, ISSN: 1429-2955, DOI: 10.15632/jtam-pl.55.4.1443, Vol.55, No.4, pp.1443-1448, 2017

## PAPERS IN OTHER JOURNALS, 2017

1. Jarzębski P., Wiśniewski K., Evaluation of Partial Factorization for Reduction of Finite Element Matrices, ENGINEERING TRANSACTIONS (ROZPRAWY INŻYNIERSKIE), ISSN: 0867-888X, Vol.65, No.1, pp.163-170, 2017
2. Będkowski J., Röhling T., Hoeller F., Schulz D., Schneider F.E., Benchmark of 6D SLAM (6D Simultaneous Localisation and Mapping) Algorithms with Robotic Mobile Mapping Systems, Foundations of Computing and Decision Sciences, ISSN: 0867-6356, DOI: 10.1515/fcds-2017-0014, Vol.42, No.3, pp.275-295, 2017
3. Lejkowski W., Dobrowolski A.P., Gawron B., Olszewski R., Wieloaspektowa Analiza Spektralna Sygnałów Fonokardiograficznych, PRZEGLĄD ELEKTRO-TECHNICZNY, ISSN: 0033-2097, DOI: 10.15199/48.2017.10.17, Vol.93, No.10, pp.73-76, 2017
4. Konowrocki R., Walczak S., Influence of Flexibility Parameters of Wheels and Wheelset on the Railway Bogie Dynamics -Experimental and Theoretical Investigations, Machine Dynamics Research, ISSN: 2080-9948, Vol.41, No.4, pp.41-53, 2017
5. Długosz A., Pokorska I., Glinicki M.A., Jaskulski R., Identification of thermal properties of hardening concrete by means of evolutionary algorithms, COMPUTER ASSISTED METHODS IN ENGINEERING AND SCIENCE, ISSN: 2299-3649, Vol.24, pp.101-111, 2017
6. Józwiak-Niedźwiedzka D., Gibas K., Glinicki M.A., Petrographic identification of reactive minerals in domestic aggregates and their classification according to rilem and astm recommendations, Roads and Bridges - Drogi i Mosty, ISSN: 1643-1618, DOI: 10.7409/rabdim.017.015, Vol.16, pp.223-239, 2017
7. Wojnar R., Heuristic derivation of Brinkman's seepage equation, Technical Sciences, ISSN: 1505-4675, Vol.20, No.4, pp.359-374, 2017
8. Fraś T., Fraś L.J., Faderl N., Rubber and magnetorheological fluid applied as the interlayer in composite armours against high-velocity loadings, DIAGNOSTYKA, ISSN: 1641-6414, Vol.18, No.3, pp.63-68, 2017
9. Rowiński P.M., Burczyński T., Duszyński J., Rychard A., Uniwersytet badawczy, czyli...?, NAUKA, ISSN: 1231-8515, Vol.3, pp.35-56, 2017
10. Widłaszewski J., Nowak M., Nowak Z., Kurp P., Laser-assisted forming of thin-walled profiles, Metal Forming, ISSN: 0867-2628, Vol.LXXXVIII, No.3, pp.183-198, 2017
11. Kukla D., Szwed M., Roskosz M., Ocena grubości warstw chromowych na stali i staliwie z wykorzystaniem metody prądów wirowych, PRZEGLĄD SPAWALNICTWA, ISSN: 0033-2364, Vol.89, No.11, pp.1-6, 2017
12. Fryczowski K., Roskosz M., Kukla D., Szwed M., Wykorzystanie szumu Barkhausena w ocenie twardości warstw nawęglanych oraz hartowanych indukcyjnie na stali AMS 6414, PRZEGLĄD SPAWALNICTWA, ISSN: 0033-2364, Vol.89, No.11, pp.1-6, 2017
13. Brzozowski Bartosz, Kawka Karol, Kaźmierczak Krzysztof, Rochala Zdzisław, Wojtowicz Konrad, Supporting the Process of Aircraft Maintenance with Mobile Devices, Transactions of the INSTITUTE of AVIATION, ISSN: 0509-6669, No.2(247), pp.7-18, 2017
14. Gibas K., Józwiak-Niedźwiedzka D., Glinicki M.A., Petrograficzna identyfikacja kruszyw podatnych na wystąpienie reakcji alkalicznej w betonie, PRACE INSTYTUTU CERAMIKI I MATERIAŁÓW BUDOWLANYCH, ISSN: 1899-3230, Vol.X, No.30, pp.68-78, 2017
15. Proniewska K., Pęgowska A., Malinowski K.P., Sleep-related breathing biomarkers as a predictor of vital functions, Bio-Algorithms and Med-Systems, ISSN: 1895-9091, DOI: 10.1515/bams-2017-0003, Vol.13, No.1, pp.43-49, 2017
16. Żurek Z.H., Kukla D., Jasiński T., Wykorzystanie mostka rlc do oceny postępu pelzania wysokotemperaturowego stali P91, ZESZYTY PROBLEMOWE - MASZYNY ELEKTRYCZNE, ISSN: 0239-3646, Vol.113, No.1, pp.215-219, 2017
17. Glinicki M.A., Brandt A.M., Dąbrowski M., Gibas K., Jaskulski R., Józwiak-Niedźwiedzka D., Baran T., Gryziński M., Ładyżyński K., Nowowiejski G., Beton osłonowy w konstrukcjach narażonych na promieniowanie jonizujące, INŻYNIERIA I BUDOWNICTWO, ISSN: 0021-0315, Vol.12, pp.637-643, 2017

18. Majka K., Krupienicz A., Olszewski R., Telepielegniarstwo w ortopedii, Medycyna Ogólna i Nauki o Zdrowiu, ISSN: 2083-4543, DOI: 10.26444/monz/75509, Vol.23, No.2, pp.94-97, 2017
19. Duszyński J., Burczyński T., Rowiński P.M., Rychard A., Projekt: Uniwersytet PAN, Nauka i Szkolnictwo Wyższe, ISSN: 1231-0298, Vol.2, No.50, pp.59-76, 2017
20. Secomski W., Wójcik J., Klimonda Z., Olszewski R., Nowicki A., Influence of absorption and scattering on the velocity of acoustic streaming, HYDROACOUSTICS, ISSN: 1642-1817, Vol.20, No.1, pp.159-166, 2017
21. Kujawska T., Dera W., Dziekoński C., Automated bimodal ultrasound device for preclinical testing of HIFU technique in treatment of solid tumors implanted into small animals, HYDROACOUSTICS, ISSN: 1642-1817, Vol.20, pp.93-98, 2017
22. Nowicki A., Dobruch-Sobczak K., Introduction to tissue shear wave elastography, HYDROACOUSTICS, ISSN: 1642-1817, Vol.20, pp.129-138, 2017
23. Żurek Z.H., Kukla D., Przetwornik Idc 1000 m w zastosowaniu do defektoskopii i badań parametrów materiału, NAPĘDY I STEROWANIE, ISSN: 1507-7764, Vol.12, pp.76-82, 2017
24. Makowski K., Kowalewski Z.L., Ziółkowski P., Badur J., Ocena stopnia uszkodzenia eksploatowanych łopatek turbiny z wykorzystaniem sygnału szumu Barkhausena, ENERGETYKA, PROBLEMY ENERGETYKI I GOSPODARKI PALIWOWO-ENERGETYCZNEJ, ISSN: 0013-7294, Vol.760, No.10, pp.638-641, 2017
25. Ołazek P., Świercz A., Wyczałek I., Kołakowski P., Szadkowski K., Moduł pomiaru i oceny odpowiedzi eksploatowanych kolejowych konstrukcji mostowych, Mosty, ISSN: 1896-7663, Vol.3-4, pp.22-26, 2017
26. Szymczak T., Kowalewski Z.L., Wybrane materiały stosowane w układach hamulcowych i ich właściwości mechaniczne, TRANSPORT SAMOCHODOWY, ISSN: 1731-2795, Vol.2, pp.87-99, 2017.

### CONFERENCE PROCEEDINGS INDEXED IN WEB OF SCIENCE, 2017

1. Kielczyński P., Szalewski M., Balcerzak A., Wieja K., Ptasznik S., Rostocki A.J., Investigation of regular and anomalous behavior of liquid media under high pressure using ultrasonic methods, 2017 IEEE, 2017 IEEE International Ultrasonics Symposium, 2017-09-06/09-09, Washington, DC (US), pp.1-4, 2017
2. Kielczyński P., Szalewski M., Balcerzak A., Wieja K., The influence of rheological parameters of viscoelastic liquids on the propagation characteristics of ultrasonic Love waves, 2017 IEEE, 2017 IEEE International Ultrasonics Symposium, 2017-09-06/09-09, Washington, DC (US), pp.1-4, 2017
3. Szolc T., Konowrocki R., Pochanke A., Michajłow M., Dynamic aspects of design and maintenance of the rotating machinery applied by the mining industry, MEC-2017, MINERAL ENGINEERING CONFERENCE, 2017-09-20/09-23, Wisła (PL), DOI: 10.1051/e3sconf/201712301010, No.18, 01010, pp.1-10, 2017
4. Wasilewski M., Pisarski D., Adaptive optimal control algorithm for vibrational systems under nonlinear friction, MMAR 2017, 22nd International Conference on Methods and Models in Automation and Robotics, 2017-08-28/08-31, Międzyzdroje (PL), pp.107-112, 2017
5. Lumelskyj D., Rojek J., Banabic D., Lazarescu L., Detection of Strain Localization in Nakazima Formability Test - Experimental Research and Numerical Simulation, SHEMET17, 17th International Conference on Sheet Metal, 2017-04-10/04-12, Palermo (IT), DOI: 10.1016/j.proeng.2017.04.016, No.183, pp.89-94, 2017
6. Topolewski P., Komorowski M., Cell cycle does not contribute to cell-to-cell heterogeneity of interferon responses, Cytokine, ISSN: 1043-4666, DOI: 10.1016/j.cyto.2017.09.011, No.Mo-P7-11, pp.100, 2017
7. Zakrzewska K.E., Jetka T., Nieniałowski K., Szymańska K., Andryka K., Topolewski P., Głów E., Komorowski M., Sensing and remembering IFNs concentrations, Cytokine, ISSN: 1043-4666, DOI: 10.1016/j.cyto.2017.09.011, No.Mo-P7-12, pp.100, 2017
8. Popławski B., Mikulowski G., Mróz A., Sekula K., Jankowski Ł., A decentralized strategy of structural reconfiguration in mitigation of vibrations, Procedia Engineering, ISSN: 1877-7058, DOI: 10.1016/j.proeng.2017.09.363, No.199, pp.1683-1688, 2017
9. Rojek J., Nosewicz S., Maździarz M., Kowalczyk P., Wawrzyk K., Lumelskyj D., Modelling of a Sintering Process at Various Scales, Procedia Engineering, ISSN: 1877-7058, DOI: 10.1016/j.proeng.2017.02.210, Vol.177, pp.263-270, 2017

### MONOGRAPHS AND BOOKS AUTHORED AND COAUTHORED BY IPPT'S RESEARCHERS, 2016

1. Hagen E., Postema M., Herzsprung auf Malle, Sine Nomine Verlag, 2016, 1 - 81, in German
2. Kleiber M., Kowalczyk P., Introduction to Nonlinear Thermomechanics of Solids, Springer, 2016, 1 - 345, in English
3. Nosewicz S., Discrete element modelling of powder metallurgy processes, IPPT Reports on Fundamental Technological Research, 2016, 5, 1 - 183, in English
4. Nowicki A., ULTRASONOGRAFIA Wprowadzenie do obrazowania i metod dopplerowskich, Wydawnictwo Instytutu Podstawowych Problemów Techniki, PAN, Warszawa, 2016, 1 - 517, in Polish
5. Suwała G., Nieparametryczna metoda zmian masy i sztywności konstrukcji, IPPT Reports on Fundamental Technological Research, 2016, 4/2016, 1 - 162, in Polish
6. Śławianowski J.J., Schroeck Jr. F.E., Martens A., Why must we work in the phase space?, IPPT Reports on Fundamental Technological Research, 2016, 1, 1 - 162, in English

7. Wiszowaty R., Projektowanie i badanie adaptacyjnych pneumatycznych absorberów energii uderzenia, IPPT PAN, 2016, 3/2016, 1 - 188, in Polish
8. Zawadzki M., Discrete Optimization in Architecture - Architectural & Urban Layout, Springer, 2016, , 1 - 105, in English
9. Zawadzki M., Discrete Optimization in Architecture - Extremely Modular Systems, Springer, 2016, , 1 - 121, in English
10. Zembrzycki K., Pawłowska S., Nakielski P., Pierini F., Development of a hybrid Atomic Force microscope and Optical Tweezers apparatus, IPPT Reports on Fundamental Technological Research, 2016, 2, 1 - 58, in English

### MONOGRAPHS AND BOOKS AUTHORED AND COAUTHORED BY IPPT'S RESEARCHERS, 2017

1. Bąk R., Burczyński T., Wytrzymałość materiałów z elementami ujęcia komputerowego, Wydawnictwo Naukowe PWN, 2017, 1 - 586, in Polish
2. Zawadzki M., Discrete Optimization in Architecture - Building Envelope, Springer, 2017, 1 - 124, in English

### MONOGRAPHS AND BOOKS COEDITED BY IPPT'S RESEARCHERS, 2016

1. Kleiber M., Burczyński T., Wilde K., Górski J., Winkelmann K., Smakosz Ł., Advances in Mechanics: Theoretical, Computational and Interdisciplinary Issues, Balkema, 2016, in English
2. Kleiber M., Burczyński T., Wilde K., Górski J., Winkelmann K., Smakosz Ł., Advances in Mechanics: Theoretical, Computational and Interdisciplinary Issues, CRC Press, Taylor & Francis Group, 2016, 1 - 632, in English
3. Meissner M., Postępy Akustyki 2016, Polskie Towarzystwo Akustyczne, Oddział Warszawski, Warszawa, Poland, 2016, 1 - 682, in English

### MONOGRAPHS AND BOOKS COEDITED BY IPPT'S RESEARCHERS, 2017

1. Podgórski J., Błazik Borowa E., Bec J., Burczyński T., Kuczma M., Latański J., Warmiński J., Computer Methods in Mechanics, AIP Publishing, 2017, 1922, in English
2. Sun Q.P., Matsui R., Takeda K., Pieczyńska E.A., Advances in Shape Memory Materials, In Commemoration of the Retirement of Professor Hisaaki Tobushi, Springer International Publishing, series Advanced Structured Materials, 2017, 73, 1 - 241, in English

## 2016 – 2017 PROJECTS

1. Mościcki Tomasz, Superhard coatings deposited by pulsed laser deposition method, 2013.01.31 – 2016.01.30; Subsidized by NCN; The acronym of the competition: SONATA
2. Lipniacki Tomasz, Inter- and intracellular signalling in innate immune response: experimental and mathematical analysis, 2012.08.06 – 2016.02.05; Subsidized by NCN; The acronym of the competition: OPUS
3. Borkowski Adam, Modelling cooperation of agents by multivalued logics and parallel processing, 2013.03.19 – 2016.03.18; Subsidized by NCN; The acronym of the competition: OPUS
4. Doliński Krzysztof, Dynamic management of transmission capacity of power networks, using innovative measurement techniques, 2014.06.01 – 2016.05.31; Subsidized by NCBIR; The acronym of the competition: GEKON
5. Maj Michał, Experimental analysis of thermomechanical couplings in micro-scale during plastic deformation of polycrystals, 2013.06.27 – 2016.06.26; Subsidized by NCN; The acronym of the competition: SONATA
6. Močko Wojciech, Influence of microstructural evolution induced by fatigue loadings on the viscoplastic response of selected materials under wide range of strain rates and temperatures, 2013.06.27 – 2016.06.26; Subsidized by NCN; The acronym of the competition: SONATA
7. Kowalewski Tomasz, Dynamics of micro and nano objects suspended in fluids, 2012.08.07 – 2016.08.06; Subsidized by NCN; The acronym of the competition: OPUS
8. Gambin Barbara, Modelling and measurements the temperature increase in soft tissue phantom and tissue samples in vitro by analysis of backscattered ultrasound field, 2012.08.30 – 2016.08.29; Subsidized by NCN; The acronym of the competition: OPUS
9. Ekiel-Jeżewska Maria, The influence of Brownian motion and interfaces on dynamics of suspensions, 2013.02.19 – 2016.10.18; Subsidized by NCN; The acronym of the competition: OPUS
10. Komorowski Michał, Scholarship for outstanding young scientists, 2013.11.20 – 2016.10.31; Subsidized by MNiSW; The acronym of the competition: Stypendia dla wybitnych młodych naukowców
11. Nosewicz Szymon, Numerical modelling of composite powder metallurgy using discrete element method, 2013.02.26 – 2016.12.25; Subsidized by NCN; The acronym of the competition: PRELUDIUM

12. Holnicki-Szulc Jan, Foundations of Adaptive Impact Absorption (AIA) and Feasibility Study of its Application to Damage Reduction in Transport Collisions, 2013.02.14 – 2017.02.13; Subsidized by NCN; The acronym of the competition: OPUS
13. Radziejewska Joanna, Development of a new testing method of dynamic hardness and selected mechanical properties of homogenous material and thin films under conditions of high stress rate, 2014.04.20 – 2017.02.19; Subsidized by NCN; The acronym of the competition: OPUS
14. Kowalczyk-Gajewska Katarzyna, Multiscale modelling of heterogeneous materials: description of microstructure evolution and scale effects, 2014.02.20 – 2017.02.19; Subsidized by NCN; The acronym of the competition: OPUS
15. Kochańczyk Marek, Formation of spatial heterogeneities on the plasma membrane and their impact on cell signaling, 2014.05.05 – 2017.03.04; Subsidized by NCN; The acronym of the competition: PRELUDIUM
16. Kołbuk-Konieczny Dorota, Influence of one- and two-component polymer substrate crystallinity degree on cells response during in-vitro study, 2014.03.13 – 2017.03.12; Subsidized by NCN; The acronym of the competition: SONATA
17. Glinicki Michał A., Durability and efficiency of concrete shields against ionizing radiation in nuclear power structures, 2014.01.01 – 2017.03.31; Subsidized by NCBiR; The acronym of the competition: PBS
18. Urbanek - Świdarska Olga, Biomimetic surface modification of bicomponent nanofibers with chondroitin sulfate and its effect on properties of scaffold and cellular response, 2015.07.14 – 2017.07.13; Subsidized by NCN; The acronym of the competition: PRELUDIUM
19. Kociniowski Paweł, Regulation of the RAF/MEK/ERK cascade involving RAF isoforms, 2014.07.17 – 2017.07.16; Subsidized by NCN; The acronym of the competition: PRELUDIUM
20. Jaruszewicz-Błońska Joanna, Stochastic phenotype switching in growing and dividing bacteria, 2015.01.23 – 2017.07.22; Subsidized by NCN; The acronym of the competition: PRELUDIUM
21. Lengiewicz Jakub, Micromechanics of Programmable Matter, 2012.08.28 – 2017.08.27; Subsidized by NCN; The acronym of the competition: SONATA
22. Komorowski Michał, Innate immune signalling: optimal microfluidics protocols, prediction and control, 2013.09.01 – 2017.09.01; Subsidized by UE; The acronym of the competition: FP7
23. Kowalczyk Tomasz, Innovative urine draining prosthesis for patients with urinary bladder cancer treated with minimum invasive urinary bladder oncological surgeries, 2014.11.01 – 2017.10.31; Subsidized by NCBiR; The acronym of the competition: STRATEGMED
24. Orłowska Anita, Analysis of mechanical properties and manufacturing process of the pre-stressed FRP composites, 2013.08.28 – 2017.11.27; Subsidized by NCN; The acronym of the competition: SONATA
25. Grady Arkadiusz, Studies on confinement effects in quasi one-dimensional geometry on phase transitions using electrospun core-shell fibers, 2015.01.22 – 2017.12.21; Subsidized by NCN; The acronym of the competition: SONATA
26. Szolc Tomasz, Innovative technology for copper ore preparation for flotation with application of high-energy comminution techniques, 2015.01.01 – 2017.12.31; Subsidized by NCBiR / Przemysł: KGHM; The acronym of the competition: CuBR
27. Nowak Łukasz, New methods and technologies for acoustic medical diagnostics, 2015.01.01 – 2017.12.31; Subsidized by NCBiR; The acronym of the competition: LIDER
28. Komorowski Michał, Innate immune signaling: optimal experimental protocols for microfluidic devices, 2013.01.01 – 2017.12.31; Subsidized by EMBO – European Molecular Biology Organization; The acronym of the competition: EMBO Grant
29. Holnicki-Szulc Jan, Active vibration cancellation with proof-mass actuators for cryo-coolers, 2017.02.01 – 2017.12.31; Subsidized by ESA; The acronym of the competition: ESA
30. Dyniewicz Bartłomiej, Semi-active damping of vibrations by using sandwich structures with a smart core, 2014.07.17 – 2018.01.16; Subsidized by NCN; The acronym of the competition: SONATA
31. Lipniacki Tomasz, Mechanism controlling cell fate decision in response to stress. Experimental and theoretical analysis., 2015.01.22 – 2018.01.21; Subsidized by NCN; The acronym of the competition: OPUS
32. Petryk Henryk, Gradient-enhanced constitutive model of crystal plasticity of metals accounting for size effects and microstructure evolution, 2015.01.22 – 2018.01.21; Subsidized by NCN; The acronym of the competition: OPUS
33. Szymański Zygmunt, Synthesis of Carbon Nanostructures by Pulsed Laser Vaporization, 2015.01.29 – 2018.01.28; Subsidized by NCN; The acronym of the competition: OPUS
34. Frańc Leszek, Dynamic properties of magnetorheological materials: experiment - modelling - identification - verification, 2016.02.15 – 2018.02.14; Subsidized by NCN; The acronym of the competition: PRELUDIUM
35. Sajkiewicz Paweł, Electrospinning of bicomponent nanofibers - synthetic polymer/biopolymer using alternative, protein non-denaturing, noncytotoxic solvents, 2014.04.20 – 2018.02.19; Subsidized by NCN; The acronym of the competition: OPUS
36. Pawłowska Sylwia, Hydrogel nanofilaments for biomedical application, 2016.02.22 – 2018.02.21; Subsidized by NCN; The acronym of the competition: PRELUDIUM
37. Holnicki-Szulc Jan, New measuring device and evaluation of dynamic responses for exploitable railway bridges, 2015.03.01 – 2018.02.28; Subsidized by NCBiR; The acronym of the competition: PBS
38. Levintant-Zayonts Neonila, Investigation of the properties and creation of thin layers with use of ion implantation technique on NiTi Shape Memory Alloy possessing micro- and nanocrystalline structures, 2014.03.13 – 2018.03.12; Subsidized by NCN; The acronym of the competition: SONATA
39. Lipniacki Tomasz, The multi-scale dynamics of signal transduction: dissecting the MAPK pathway, 2015.05.01 – 2018.04.30; Subsidized by WWTF - Vienna Science and Technology Fund; The acronym of the competition: WWTF Mathematik und...

40. Ekiel-Jeżewska Maria, Flowing matter - MPNS COST Action MP1305, 2014.05.06 – 2018.05.05; Subsidized by UE; The acronym of the competition: ESF
41. Korczyk Piotr, The study of hydrodynamic interactions of droplets in complex microfluidic structures. The analysis of algorithms encoded in the architecture of microchannels enabling dosing of the reactants with arbitrary precision, 2015.05.07 – 2018.05.06; Subsidized by NCN; The acronym of the competition: SONATA BIS
42. Nowicki Andrzej, Assessment of neoplastic lesions using parametric discrimination of the statistical properties of ultrasound scattering in breast tissue, 2015.01.23 – 2018.05.22; Subsidized by NCN; The acronym of the competition: OPUS
43. Rojek Jerzy, Multiscale numerical modelling of sintering processes, 2014.08.07 – 2018.06.06; Subsidized by NCN; The acronym of the competition: OPUS
44. Lipniacki Tomasz, Innate immune response to RSV infection, role of non-structural proteins. Experiments and modelling of signal transduction and among cells communication, 2015.06.08 – 2018.06.07; Subsidized by NCN; The acronym of the competition: HARMONIA
45. Chrzanowska-Giżyńska Justyna, Super hard thin layers of borides of tungsten - the effect of microstructure and chemical composition on physico-chemical properties, 2016.07.06 – 2018.07.05; Subsidized by NCN; The acronym of the competition: PRELUDIUM
46. Kowalewski L. Zbigniew, Elaboration of fundamentals for a new, interdisciplinary method of damage development monitoring of materials on the basis of structural defects investigation, 2015.07.24 – 2018.07.23; Subsidized by NCN; The acronym of the competition: OPUS
47. Basista Michał, Influence of Thermal Residual Stresses on Fracture Behaviour and selected Mechanical Properties of Metal-Ceramic Composites: Experiments and Modelling, 2015.08.03 – 2018.08.02; Subsidized by NCN; The acronym of the competition: OPUS
48. Jankowski Łukasz, Development and efficiency assessment of new algorithms for identification and modelling of structural damping at the local level and for optimum design and semiactive control of dissipative structures, 2015.08.05 – 2018.08.04; Subsidized by NCN; The acronym of the competition: OPUS
49. Secomski Wojciech, Ultrasonic streaming aided thrombolysis, 2015.08.05 – 2018.08.04; Subsidized by NCN; The acronym of the competition: OPUS
50. Widłaszewski Jacek, Mechanically assisted laser forming of thin-walled profiles, 2015.09.01 – 2018.08.31; Subsidized by NCBiR; The acronym of the competition: PBS
51. Witecka Agnieszka, Fabrication and characterization of electrophoretically deposited chitosan-bioactive glass composite coatings on Mg-based substrate., 2017.10.04 – 2018.10.03; Subsidized by NCN; The acronym of the competition: MINIATURA
52. Lewandowski Marcin, The introduction of the original Polish implantable rotary pump cardiac support, remote monitoring system and remotely supervised rehabilitation of patients with heart support, 2015.11.01 – 2018.10.31; Subsidized by NCBiR; The acronym of the competition: STRATEGMED
53. Kowalewski Zbigniew, Turbine drive - advanced manufacturing techniques, 2013.12.01 – 2018.11.30; Subsidized by NCBiR / Przemysł: PZL Świdnik; The acronym of the competition: INNOLOT
54. Glinicki Michał A., Alkaline reactivity of domestic mineral aggregates, 2016.01.01 – 2018.12.31; Subsidized by NCBiR / Przemysł: GDDKiA; The acronym of the competition: RID
55. Jarząbek Dariusz, The design of compact nanotensile tester, 2016.01.01 – 2018.12.31; Subsidized by NCBiR; The acronym of the competition: LIDER
56. Karwat Piotr, Application of synthetic aperture algorithm in reconstruction of distribution of ultrasound propagation speed in soft tissue, 2017.01.17 – 2019.01.16; Subsidized by NCN; The acronym of the competition: PRELUDIUM
57. Zawidzki Maciej, Innovative Extremely Modular Systems for temporary and permanent deployable structures and habitats: development, modelling, evaluation & optimization, 2017.02.01 – 2019.01.31; Subsidized by NCN; The acronym of the competition: POLONEZ
58. Bajer Czesław, Modelling and control of structural vibrations with the use of smart materials, 2016.02.10 – 2019.02.09; Subsidized by NCN; The acronym of the competition: OPUS
59. Pieczyńska Elżbieta, Investigation of thermomechanical properties of Gum Metal - a new titanium alloy with high elasto-plastic properties, unknown deformation mechanisms and great potential for practical application, 2015.02.11 – 2019.02.10; Subsidized by NCN; The acronym of the competition: OPUS
60. Dulnik Judyta, The effect of crosslinking conditions on structure and properties of bicomponent PCL/gelatin nanofibres from alternative solvents, 2016.02.15 – 2019.02.14; Subsidized by NCN; The acronym of the competition: PRELUDIUM
61. Lewandowski Maciej, New model of contact of higher-order solids and its numerical implementation, 2016.02.15 – 2019.02.14; Subsidized by NCN; The acronym of the competition: PRELUDIUM
62. Stupkiewicz Stanisław, Finite-strain phase-field model of evolution of martensitic microstructures in shape memory alloys, 2016.02.15 – 2019.02.14; Subsidized by NCN; The acronym of the competition: OPUS
63. Ekiel-Jeżewska Maria, Microhydrodynamics of soft matter, 2015.07.13 – 2019.03.12; Subsidized by NCN; The acronym of the competition: OPUS
64. Komorowski Michał, Phosphorylation dynamics of STAT1, STAT3 and STAT5 proteins in breast cancer cell lines - systematic experimental and theoretical analysis, 2016.03.15 – 2019.03.14; Subsidized by NCN; The acronym of the competition: OPUS
65. Szmidt Tomasz, Stability and non-linear dynamics of an electromagnetically damped pipe conveying fluid, 2016.03.17 – 2019.03.16; Subsidized by NCN; The acronym of the competition: SONATA
66. Kołbuk-Konieczny Dorota, Development of bioactive, hybrid material for ACL ligament regeneration, 2016.04.01 – 2019.03.31; Subsidized by NCBiR; The acronym of the competition: LIDER
67. Kukła Dominik, Development of non-destructive methods for characterization of layers of carburized gear wheels, 2015.09.01 – 2019.05.31; Subsidized by NCBiR; The acronym of the competition: PBS

68. Nasalski Wojciech, Modelling and optimization of interactions of vortex vector optical beams with planar plasmonic structures, 2016.07.05 – 2019.07.04; Subsidized by NCN; The acronym of the competition: OPUS
69. Zembrzycki Krzysztof, Analysis of hydrodynamic interactions of single particles by the use of optical tweezers., 2016.07.06 – 2019.07.05; Subsidized by NCN; The acronym of the competition: PRELUDIUM
70. Wichrowski Michał, Scalable computational methods for fluid-structure interaction, 2016.07.08 – 2019.07.07; Subsidized by NCN; The acronym of the competition: PRELUDIUM
71. Zieliński Tomasz, Relations between the micro-geometry and sound propagation and absorption in porous and poroelastic media, 2016.07.08 – 2019.07.07; Subsidized by NCN; The acronym of the competition: OPUS
72. Jarząbek Dariusz, External and internal size effects and their coupling in single crystals and nanocrystalline materials investigated with compression, tension and bending of nanopillars and nanowires, 2016.07.08 – 2019.07.07; Subsidized by NCN; The acronym of the competition: SONATA
73. Gruzziel Magdalena, Numerical and experimental studies of sedimentation of chiral, knotted fibers, 2016.07.08 – 2019.07.07; Subsidized by NCN; The acronym of the competition: SONATA
74. Nakielski Paweł, Investigation of blood clotting mechanism in the contact with nanofibers, 2016.07.11 – 2019.07.10; Subsidized by NCN; The acronym of the competition: SONATA
75. Pierini Filippo, Stimuli-reponsive chiral nematic liquid crystal hydrogel implants by electrospinning technique, 2016.07.11 – 2019.07.10; Subsidized by NCN; The acronym of the competition: SONATA
76. Rojek Jerzy, New formulation of the deformable discrete element method, 2016.07.18 – 2019.07.17; Subsidized by NCN; The acronym of the competition: OPUS
77. Litniewski Jerzy, Methods for determining new ultrasonic parameters of tumor tissue. Their physical interpretation and evaluation of the usefulness in the diagnosis of breast cancer, 2017.07.24 – 2019.07.23; Subsidized by NCN; The acronym of the competition: OPUS
78. Nieniałowski Karol, Detecting origins of signalling aberrations in cancer cells, 2017.07.26 – 2019.07.25; Subsidized by NCN; The acronym of the competition: PRELUDIUM
79. Faraj Rami, Innovative systems for safe airdrop DROPS, 2015.08.31 – 2019.08.30; Subsidized by MNiSW; The acronym of the competition: Diamentowy Grant
80. Holnicki-Szulc Jan, Application of the AIA concept (Adaptive Impact Absorption) in aeronautical and space engineering, AIA-AERO, 2017.03.01 – 2019.08.31; Subsidized by NCBiR; The acronym of the competition: TANGO
81. Piechocka Izabela, The effect of shear flow on fibrin clot structure and fibrin-platelets interactions, 2017.10.01 – 2019.09.30; Subsidized by FNP; The acronym of the competition: POIR
82. Kielczyński Piotr, Identification of rheological parameters of viscoelastic media on the example of liquid and solid polymers by ultrasonic surface Love waves, 2017.01.13 – 2020.01.12; Subsidized by NCN; The acronym of the competition: OPUS
83. Kaźmierczak Bogdan, Non-standard parabolic problems in description of biological processes, 2017.01.16 – 2020.01.15; Subsidized by NCN; The acronym of the competition: OPUS
84. Kujawska Tamara, Automated sonic tumor treatment, 2017.01.17 – 2020.01.16; Subsidized by NCN; The acronym of the competition: OPUS
85. Meissner Mirosław, Steady-state and transient energetic sound field parameters for objective evaluation of acoustics of enclosed spaces: theoretical modelling and computer simulations, 2017.02.03 – 2020.02.02; Subsidized by NCN; The acronym of the competition: OPUS
86. Burczyński Tadeusz, Intelligent design of 2D nanostructures based on molybdenum, 2017.02.06 – 2020.02.05; Subsidized by NCN; The acronym of the competition: OPUS
87. Pierini Filippo, Design, construction and optimization of a combined Atomic Force Microscope and Optical Tweezers instrument for single molecules and nanomaterials characterization, 2017.03.01 – 2020.02.29; Subsidized by NCBiR; The acronym of the competition: LIDER
88. Pęcherski Ryszard, , 2017.05.01 – 2020.04.30; Subsidized by NCBiR / Przemysł: KGHM; The acronym of the competition: CuBR
89. Sajkiewicz Paweł, The use of collagen for surface functionalization using chemical methods of polycaprolactone nanofibers formed by electrospinning technique, 2017.07.10 – 2020.07.09; Subsidized by NCN; The acronym of the competition: OPUS
90. Kowalczyk-Gajewska Katarzyna, Optimization of microstructure in heterogeneous materials - micromechanical and numerical modelling in non-linear regime, 2017.07.10 – 2020.07.09; Subsidized by NCN; The acronym of the competition: OPUS
91. Golański Karol, Gum Metal under compressive loading - interdisciplinary investigation of an innovative Ti-based superalloy, 2017.07.12 – 2020.07.11; Subsidized by NCN; The acronym of the competition: PRELUDIUM
92. Denis Piotr, Elastic nonwovens with poly(glycerol sebacate) obtained by electrospinning method, 2017.07.28 – 2020.07.27; Subsidized by NCN; The acronym of the competition: PRELUDIUM
93. Krajewski Marcin, New functional core-shell composite nanomaterials with iron-cobalt and iron-nickel cores: preparation, properties and influence of oxidizing atmosphere and temperature on the shell growth, 2017.09.29 – 2020.09.28; Subsidized by NCN; The acronym of the competition: SONATA
94. Basista Michał, Innovative Ni-Cr-Re coatings with enhanced corrosion and erosion resistance for high temperature applications in power generation industry, 2017.10.01 – 2020.09.30; Subsidized by NCBiR; The acronym of the competition: M-ERA.NET 2016
95. Sajkiewicz Paweł, PANDA 2 - maintenance of CEPT infrastructure, 2016.12.30 – 2020.12.31; Subsidized by NCBiR; The acronym of the competition: PANDA

## OTHER PROJECTS

1. Walczyk-Matuszyk Katarzyna, Transnational Network for cooperation of WIDESPREAD NCPs, 2015.01.01 – 2019.12.31; Subsidized by European Commission, Horizon 2020, Acronym: NCP\_WIDE.NET
2. Wiśniewska Anna, Transnational cooperation among Marie Skłodowska-Curie National Contact Points, 2015.03.01 – 2018.01.31; Subsidized by European Commission, Horizon 2020, Acronym: Net4Mobility
3. Podlaska Bożena, Cooperation between NCPs for Horizon 2020 Societal Challenge 2 on "Food security, Sustainable Agriculture, Marine and Maritime Research and the Bioeconomy and the Key Enabling Technology (KET) "Biotechnology improving professionalism NCP service across Europe, 2015.02.01 – 2019.02.28; Subsidized by European Commission, Horizon 2020, Acronym: BioHorizon
4. Ilnatowicz Aleksandra, Galik Andrzej, Transnational cooperation among ICT NCPs, 2015.01.01 – 2018.12.31; Subsidized by European Commission, Horizon 2020, Acronym: Idealist2018
5. Pyczak Mikołaj, Transnational network of National Contact Points (NCPs) of Societal Challenge 6 'Europe in a changing world . inclusive, innovative and reflective Societies' (SC6), 2015.02.01 – 2019.01.31; Subsidized by European Commission, Horizon 2020, Acronym: NET4SOCIETY4
6. Szkiłdź Ewa, Improving and professionalizing the Health, Demographic Change and Wellbeing NCP service across Europe, 2014.12.01 – 2018.11.30; Subsidized by European Commission, Horizon 2020, Acronym: HNN 2.0
7. Krótki Małgorzata, Network of Science with and for Society National Contact Points, 2014.11.01 – 2018.12.31; Subsidized by European Commission, Horizon 2020, Acronym: SiS.net2
8. Świerczyński Piotr, Cooperation Of Space NCPs as a Means to Optimise Services under Horizon 2020, 2015.01.01 – 2018.12.31; Subsidized by European Commission, Horizon 2020, Acronym: COSMOS2020
9. Głuszuk Adam, Research Infrastructures Consortium for Horizon 2020, 2014.12.01 – 2018.11.30; Subsidized by European Commission, Horizon 2020, Acronym: RICH
10. Krasieński Zygmunt, Serwiak Sebastian, National Contact Points for quality standards and horizontal issues, 2014.12.10 – 2018.06.09; Subsidized by European Commission, Horizon 2020, Acronym: NCP ACADEMY
11. Wiśniewska Anna, Making European research careers more attractive by developing new services and enhancing the current services of the EURAXESS network., 2015.09.01 – 2018.08.31; Subsidized by European Commission, Horizon 2020, Acronym: EURAXESS TOP III
12. Turek Zbigniew, European Transport Network Alliance 2020, 2016.01.01 – 2019.12.31; Subsidized by European Commission, Horizon 2020, Acronym: ETNA 2020
13. Świerczyński Piotr, Security Research NCP Network 3, 2015.05.01 – 2018.04.30; Subsidized by European Commission, Horizon 2020, Acronym: SEREN 3
14. Głogowska Magdalena, National Contact points for Climate action, Raw materials, Environment and Resource Efficiency, 2015.02.01 – 2019.01.31; Subsidized by European Commission, Horizon 2020, Acronym: NCP's CaRE
15. Piekarski Jarosław, Improving the services of the NMP NCP Network through Transnational Activities, 2015.01.01 – 2016.12.31; Subsidized by European Commission, Horizon 2020, Acronym: NMP TeAm 3
16. Maszewska Aneta, Connecting EURATOM National Contact Points in a proactive network under EURATOM Programme in H2020, 2015.09.01 – 2019.08.31; Subsidized by European Commission, Horizon 2020, Acronym: NUCL.EU 2020
17. Krasieński Zygmunt, Enhanced bi.regional STI cooperation between the EU and the Black Sea Region, 2015.02.01 – 2018.01.31; Subsidized by European Commission, Horizon 2020, Acronym: BLACK SEA HORIZON
18. Krasieński Zygmunt, Strengthening Research and Innovation Links towards Ukraine, 2016.02.15 – 2019.02.14; Subsidized by European Commission, Horizon 2020, Acronym: RI.LINKS2UA
19. Śmietanka Maria, Connecting Energy National Contact Points in a proactive network under Societal Challenge 3 'Secure, clean and efficient energy' in Horizon 2020, 2014.12.01 – 2018.11.30; Subsidized by European Commission, Horizon 2020, Acronym: C.ENERGY 2020
20. Krasieński Zygmunt, STI International Cooperation Network for Eastern Partnership Countries – PLUS, 2016.09.01 – 2019.08.31; Subsidized by European Commission, Horizon 2020, Acronym: EaP PLUS
21. Walczyk-Matuszyk Katarzyna, Access to Risk Finance and SMEs NCP cooperation network, 2016.09.01 – 2019.02.28; Subsidized by European Commission, Horizon 2020, Acronym: ACCESS4SMES
22. Wiśniewska Anna, Polish ERA Mobility and Career Days, 2017.04.01 – 2018.02.28; Subsidized by European Commission, Horizon 2020, Acronym: PL.ERADAYS
23. Piekarski Jarosław, Improving the services of the NMP NCP Network through Transnational Activities 4, 2017.01.01 – 2018.12.31; Subsidized by European Commission, Horizon 2020, Acronym: NMP TeAm 4

# 21. STAFF AT THE INSTITUTE (AS OF DECEMBER 31, 2017)



Adamczyk Anna	Accounting Office
Antolik Aneta	Department of Experimental Mechanics
Augustynowicz Maria	Accounting Office
Bajer Czesław	Department of Intelligent Technologies
Balcerzak Andrzej	Department of Theory of Continuous Media and Nanostructures
Banach Zbigniew	Department of Theory of Continuous Media and Nanostructures
Basista Michał	Department of Mechanics of Materials
Bednarek Mirosław	National Contact Point
Będkowski Janusz	Department of Intelligent Technologies
Białecki Sławomir	Department of Biosystems and Soft Matter
Błachowski Bartłomiej	Department of Intelligent Technologies
Błoński Sławomir	Department of Biosystems and Soft Matter
Bochenek Kamil	Department of Mechanics of Materials
Bukowicki Marek	Department of Biosystems and Soft Matter
Burczyński Tadeusz	Department of Information and Computational Science
Byra Michał	Department of Ultrasound
Całka Jan	Department of Intelligent Technologies
Chałupczak Zbigniew	Administrative and Technical Services
Chojnacki Andrzej	Department of Experimental Mechanics
Chomiccka Magdalena	National Contact Point
Chorab Mirosław	Laboratory Services Centre
Chrzanowska-Giżyńska Justyna	Department of Experimental Mechanics
Cichacki Łukasz	Laboratory Services Centre
Ciesielska Aneta	Secretary and Administrative Office
Cieślak Aneta	Accounting Office
Czeladko Renata	National Contact Point
Czerkies Maciej	Department of Biosystems and Soft Matter
Czubacka Urszula	Department of Mechanics of Materials
Dawidziuk Marek	Department of Theory of Continuous Media and Nanostructures
Dąbrowski Mariusz	Department of Experimental Mechanics
Denis Piotr	Laboratory of Polymers and Biomaterials
Dera Wojciech	Department of Theory of Continuous Media and Nanostructures
Dębowski Tomasz	Department of Experimental Mechanics
Dłużewski Paweł	Department of Information and Computational Science
Dobruć-Sobczak Katarzyna	Department of Ultrasound
Dolanowski Ryszard	National Contact Point
Draczyński Antoni	Administrative and Technical Services
Duczmal Rafał	National Contact Point
Dulnik Judyta	Laboratory of Polymers and Biomaterials
Duszyńska Sława	National Contact Point
Dworakowski Zbigniew	Computing Services
Dybko Mikołaj	Computing Services
Dyniewicz Bartłomiej	Department of Intelligent Technologies
Dziedzic Kinga	Department of Experimental Mechanics

Dziekoński Cezary	Department of Theory of Continuous Media and Nanostructures
Dziubczyńska-Pytka Anna	National Contact Point
Ekiel-Jeżewska Maria	Department of Biosystems and Soft Matter
Florczak Krzysztof	Administrative and Technical Services
Frąś Leszek	Department of Theory of Continuous Media and Nanostructures
Frydrych Karol	Department of Mechanics of Materials
Galik Andrzej	National Contact Point
Gambin Barbara	Department of Ultrasound
Gawlak Elżbieta	Human Resources Office
Gibas Karolina	Department of Experimental Mechanics
Glinicki Michał	Department of Experimental Mechanics
Głogowska Magdalena	National Contact Point
Głuszak Adam	National Contact Point
Gołubowska Barbara	Department of Theory of Continuous Media and Nanostructures
Graczykowski Cezary	Department of Intelligent Technologies
Gradys Arkadiusz	Laboratory of Polymers and Biomaterials
Gruziel Magdalena	Department of Biosystems and Soft Matter
Grzebielichowski Erwin	Department of Experimental Mechanics
Grzechnik Zofia	Secretary and Administrative Office
Grzywna Paweł	Department of Experimental Mechanics
Gwadera Anna	Accounting Office
Hat-Plewińska Beata	Department of Biosystems and Soft Matter
Hoffman Jacek	Department of Experimental Mechanics
Holnicki-Szulc Jan	Department of Intelligent Technologies
Hołobut Paweł	Department of Mechanics of Materials
Hryniszyn Bogna	National Contact Point
Ilnatowicz Aleksandra	National Contact Point
Jain Amrita	Department of Theory of Continuous Media and Nanostructures
Jankowska Magdalena	Publishing Office
Jankowski Łukasz	Department of Intelligent Technologies
Jarecki Leszek	Department of Theory of Continuous Media and Nanostructures
Jaruszewicz-Błońska Joanna	Department of Biosystems and Soft Matter
Jarząbek Dariusz	Department of Mechanics of Materials
Jezierska Katarzyna	Publishing Office
Jóźwiak-Niedźwiedzka Daria	Department of Experimental Mechanics
Jurczak Grzegorz	Department of Information and Computational Science
Jurkowska Marta	National Contact Point
Kalińska Monika	Library
Kapica Małgorzata	National Contact Point
Karwat Piotr	Department of Ultrasound
Katz Tomasz	Department of Experimental Mechanics
Kaźmierczak Bogdan	Department of Biosystems and Soft Matter
Kaźmierczak Krzysztof	Department of Intelligent Technologies
Kąkol Jolanta	Administrative and Technical Services



Kielczyński Piotr..... Department of Theory of Continuous Media and Nanostructures  
 Kisielińska Marta..... Management and Research Coordination Office  
 Kleiber Michał..... Department of Information and Computational Science  
 Klimonda Ziemowit..... Department of Ultrasound  
 Kłosińska Bożena..... Administrative and Technical Services  
 Kochańczyk Marek..... Department of Biosystems and Soft Matter  
 Kochutek Teresa..... Finance Office  
 Kocieniewski Paweł..... Department of Biosystems and Soft Matter  
 Kołbuk-Konieczny Dorota..... Laboratory of Polymers and Biomaterials  
 Komorowski Michał..... Department of Biosystems and Soft Matter  
 Konowrocki Robert..... Department of Intelligent Technologies  
 Kopeć Mateusz..... Department of Experimental Mechanics  
 Korczyk Piotr..... Department of Biosystems and Soft Matter  
 Korwek Zbigniew..... Department of Biosystems and Soft Matter  
 Koszałka Anna..... Administrative and Technical Services  
 Kowalczyk Wasyl..... Department of Theory of Continuous Media and Nanostructures  
 Kowalczyk Maciej..... Computing Services  
 Kowalczyk Tomasz..... Laboratory of Polymers and Biomaterials  
 Kowalczyk Piotr..... Department of Information and Computational Science  
 Kowalczyk-Gajewska Katarzyna..... Department of Mechanics of Materials  
 Kowalewski Tomasz..... Department of Biosystems and Soft Matter  
 Kowalewski Zbigniew..... Department of Experimental Mechanics  
 Krajewski Marcin..... Department of Mechanics of Materials  
 Krasieński Zygmunt..... National Contact Point  
 Kraskowski Marcin..... Management and Research Coordination Office  
 Kraskowski Jan..... Department of Experimental Mechanics  
 Krawczyk Andrzej..... Deputy Director for Investments  
 Krótki Małgorzata..... National Contact Point  
 Kruglenko Eleonora..... Department of Ultrasound  
 Krutel Marta..... National Contact Point  
 Kucharczyk Joanna..... National Contact Point  
 Kucharczyk-Świerczyńska Iwona..... National Contact Point  
 Kucharski Stanisław..... Department of Mechanics of Materials  
 Kuczmerska Mirosława..... Administrative and Technical Services  
 Kuczyńska Beata..... Archives  
 Kujawska Tamara..... Department of Ultrasound  
 Kukła Dominik..... Department of Experimental Mechanics  
 Kursa Michał..... Department of Mechanics of Materials  
 Kwaśnicki Zygmunt..... Administrative and Technical Services  
 Lankiewicz Emilia..... Accounting Office  
 Larecki Wiesław..... Department of Theory of Continuous Media and Nanostructures  
 Lejman Artemina..... Administrative and Technical Services  
 Lempkowski Bogusław..... Publishing Office  
 Lengiewicz Jakub..... Department of Mechanics of Materials

Leśnicka Anna..... Chief Accountant  
 Levintant-Zayonts Neonila..... Department of Mechanics of Materials  
 Lewandowska Alfreda..... Administrative and Technical Services  
 Lewandowska-Gruszka Bogusława..... Library  
 Lewandowski Marcin..... Department of Experimental Mechanics  
 Libura Tomasz..... Department of Experimental Mechanics  
 Lipińska Katarzyna..... Management and Research Coordination Office  
 Lipniacki Tomasz..... Department of Biosystems and Soft Matter  
 Litniewski Jerzy..... Department of Ultrasound  
 Lumelskyj Dmytro..... Department of Information and Computational Science  
 Łęga Lilla..... Administrative and Technical Services  
 Mackiewicz Sławomir..... Department of Experimental Mechanics  
 Maj Justyna..... Department of Mechanics of Materials  
 Maj Michał..... Department of Mechanics of Materials  
 Majewski Bartosz..... National Contact Point  
 Małachowska-Tymkiewicz Joanna..... International Cooperation Office  
 Martens Agnieszka..... Department of Theory of Continuous Media and Nanostructures  
 Maszewska Aneta..... National Contact Point  
 Maździarz Marcin..... Department of Information and Computational Science  
 Meissner Mirosław..... Department of Intelligent Technologies  
 Mika Izabela..... Publishing Office  
 Mikułowski Grzegorz..... Department of Intelligent Technologies  
 Milczarek Agnieszka..... Human Resources Office  
 Milewska Monika..... Management and Research Coordination Office  
 Misztal-Faraj Beata..... Department of Theory of Continuous Media and Nanostructures  
 Miśtał Grażyna..... Administrative and Technical Services  
 Mościcki Tomasz..... Department of Experimental Mechanics  
 Mróz Tomasz..... National Contact Point  
 Myczka Artur..... Department of Experimental Mechanics  
 Nakielski Paweł..... Department of Biosystems and Soft Matter  
 Nasalski Wojciech..... Department of Theory of Continuous Media and Nanostructures  
 Niedziałek Joanna..... National Contact Point  
 Niewęglowski Kazimierz..... Administrative Office  
 Nikitin Urszula..... National Contact Point  
 Nosewicz Szymon..... Department of Information and Computational Science  
 Nowak Marcin..... Department of Mechanics of Materials  
 Nowak Zdzisław..... Department of Theory of Continuous Media and Nanostructures  
 Nowicki Andrzej..... Department of Ultrasound  
 Olszewski Robert..... Department of Ultrasound  
 Omarska Grażyna..... Administrative Office  
 Orłowska Anita..... Department of Intelligent Technologies  
 Osuch-Rak Ewa..... Department of Intelligent Technologies  
 Palińska Magdalena..... Secretary and Administrative Office  
 Pałycka Elżbieta..... Payroll Office

Parkitna Katarzyna .....Administrative Office  
 Pawelek Teresa .....Centre for Commercialization of Research Results and Technology Transfer  
 Pawlik Agnieszka .....Management and Research Coordination Office  
 Pawłowska Sylwia .....Department of Biosystems and Soft Matter  
 Pawłowski Piotr .....Department of Intelligent Technologies  
 Petryk Henryk .....Department of Mechanics of Materials  
 Pęcherski Ryszard .....Department of Theory of Continuous Media and Nanostructures  
 Piechocka Izabela .....Department of Biosystems and Soft Matter  
 Piecyk Paweł .....Computing Services  
 Pieczyska Elżbieta .....Department of Experimental Mechanics  
 Piekarski Jarosław .....National Contact Point  
 Pierini Filippo .....Department of Biosystems and Soft Matter  
 Pietrzak Katarzyna .....Department of Mechanics of Materials  
 Pindakiewicz Przemysław .....Computing Services  
 Piotrkowska-Wróblewska Hanna .....Department of Ultrasound  
 Pisarski Dominik .....Department of Intelligent Technologies  
 Pływaczewska Martyna .....Laboratory of Polymers and Biomaterials  
 Podlaska Bożena .....National Contact Point  
 Ponarska Agnieszka .....Secretary and Administrative Office  
 Poniżnik Zuzanna .....Department of Mechanics of Materials  
 Postek Eligiusz .....Department of Information and Computational Science  
 Pręgowska Agnieszka .....Department of Biosystems and Soft Matter  
 Prus Wiktor .....Department of Biosystems and Soft Matter  
 Putek Piotr .....Computing Services  
 Pyczak Mikołaj .....National Contact Point  
 Radziejewska Joanna .....Department of Experimental Mechanics  
 Ranachowski Przemysław .....Department of Experimental Mechanics  
 Ranachowski Zbigniew .....Department of Experimental Mechanics  
 Rojek Jerzy .....Department of Information and Computational Science  
 Roszkiewicz-Walczyk Agata .....Department of Theory of Continuous Media and Nanostructures  
 Rozbicki Jakub .....Department of Experimental Mechanics  
 Rożko Ewa .....Department of Theory of Continuous Media and Nanostructures  
 Rybak Anna .....Administrative and Technical Services  
 Rycerz Renata .....National Contact Point  
 Ryś Maciej .....Department of Mechanics of Materials  
 Sadowski Przemysław .....Department of Mechanics of Materials  
 Sajkiewicz Paweł .....Laboratory of Polymers and Biomaterials  
 Sarnowska Anna .....National Contact Point  
 Secomski Wojciech .....Department of Ultrasound  
 Sekuła Katarzyna .....Publishing Office  
 Serwiak Sebastian .....National Contact Point  
 Siemaszko Andrzej .....Centre of Technology  
 Siewko-Ruszel Emilia .....Payroll Office  
 Słomiński Piotr .....Management and Research Coordination Office

Słowicka Agnieszka .....Department of Biosystems and Soft Matter  
 Słysz Ewelina .....National Contact Point  
 Smoleńska Patrycja .....National Contact Point  
 Sobczak Maciej .....Department of Experimental Mechanics  
 Sokalska Agnieszka .....Secretary and Administrative Office  
 Sokalska Joanna .....National Contact Point  
 Sokolowska-Todorska Joanna .....Payroll Office  
 Stanisławska Aleksandra .....National Contact Point  
 Starzyński Grzegorz .....Department of Mechanics of Materials  
 Staszczak Maria .....Department of Experimental Mechanics  
 Steifer Tomasz .....Department of Experimental Mechanics  
 Struska Magdalena .....Department of Intelligent Technologies  
 Strzałkowski Ryszard .....Department of Ultrasound  
 Stupkiewicz Stanisław .....Department of Mechanics of Materials  
 Suska Elżbieta .....National Contact Point  
 Suwała Grzegorz .....Department of Intelligent Technologies  
 Sykłowska Luiza .....Secretary and Administrative Office  
 Szczepański Janusz .....Department of Biosystems and Soft Matter  
 Szkiłdź Ewa .....National Contact Point  
 Szklarski Jacek .....Department of Intelligent Technologies  
 Szmidt Tomasz .....Department of Intelligent Technologies  
 Szmit Katarzyna .....Secretary and Administrative Office  
 Szolc Tomasz .....Department of Intelligent Technologies  
 Szolucha Małgorzata .....National Contact Point  
 Szymański Zygmunt .....Department of Experimental Mechanics  
 Ślifska Agnieszka .....National Contact Point  
 Śmietanka Maria .....National Contact Point  
 Świczka Magdalena .....Finance Office  
 Świercz Andrzej .....Department of Intelligent Technologies  
 Świerczyński Piotr .....National Contact Point  
 Tasinkiewicz Jurij .....Department of Ultrasound  
 Tazowski Piotr .....Department of Information and Computational Science  
 Tomaszewska Jadwiga .....Library  
 Trammer Barbara .....National Contact Point  
 Trawiński Zbigniew .....Department of Ultrasound  
 Trots Ihor .....Department of Ultrasound  
 Turek Zbigniew .....National Contact Point  
 Tymkiewicz Ryszard .....Department of Ultrasound  
 Urbanek-Świdorska Olga .....Laboratory of Polymers and Biomaterials  
 Urbańska Aneta .....Finance Office  
 Urbański Leszek .....Department of Mechanics of Materials  
 Ustrzycka Aneta .....Department of Experimental Mechanics  
 Walczak Mateusz .....Department of Experimental Mechanics  
 Walczyk-Matuszyk Katarzyna .....National Contact Point

Wałęcki Marcin	National Contact Point
Wasilewska Anna	Administrative and Technical Services
Wąsowska Olga	National Contact Point
Węglewski Witold	Department of Mechanics of Materials
Węglowska Monika	Secretary and Administrative Office
Widłaszewska Elżbieta	Secretary and Administrative Office
Widłaszewski Jacek	Department of Experimental Mechanics
Wieczoryński Marek	Administrative and Technical Services
Wieja Krzysztof	Department of Theory of Continuous Media and Nanostructures
Wieliczko-Gutowska Anieli	Human Resources Office
Wiszwaty Rafał	Department of Intelligent Technologies
Wiśniewska Teresa	Payroll Office
Wiśniewska Anna	National Contact Point
Wiśniewski Krzysztof	Department of Information and Computational Science
Witecka Agnieszka	Department of Mechanics of Materials
Witek Beata	Department of Experimental Mechanics
Włodarczyk Dorota	National Contact Point
Wolska Magdalena	Centre for Commercialization of Research Results and Technology Transfer
Wołęjsza Zbigniew	Department of Intelligent Technologies
Woźniacka Stefania	Department of Mechanics of Materials
Wójcik Janusz	Department of Ultrasound
Wyszkowski Mirosław	Department of Experimental Mechanics
Young Toby	Department of Information and Computational Science
Zadrużna Elżbieta	Secretary and Administrative Office
Zakrzewska Karolina	Department of Biosystems and Soft Matter
Zaremba Monika	National Contact Point
Zawidzki Maciej	Department of Intelligent Technologies
Zawiślak Grażyna	Administrative and Technical Services
Zduńczyk Mariusz	Administrative and Technical Services
Zduńczyk Edyta	National Contact Point
Zembrzycki Krzysztof	Department of Biosystems and Soft Matter
Zieliński Tomasz	Department of Intelligent Technologies
Zielonkiewicz Marcin	National Contact Point
Ziółkowski Andrzej	Department of Intelligent Technologies
Zyrina Olga	National Contact Point
Żolek Norbert	Department of Ultrasound
Żuk Paweł	Department of Biosystems and Soft Matter
Żywczyk Łukasz	Department of Mechanics of Materials

## WARSZAWA 2018

Production: Katarzyna Parkitna, Assoc. Prof. Piotr Kowalczyk (academic consultant), Daria Wieliczko-Dzidek (language consultant)

Photo credit: Adam Holnicki-Szulc, Piotr Denis, Katarzyna Parkitna, Sława Duszyńska (NCP), Renata Czeladko (NCP), Piotr Tazowski, Grzegorz Jakubowski and Krzysztof Sitkowski (the President's Office), Agata Materowicz



## CONTACT:

INSTITUTE OF FUNDAMENTAL TECHNOLOGICAL RESEARCH  
POLISH ACADEMY OF SCIENCES

Pawńskiego 5B, 02-106 Warszawa, Poland  
phone: +48 22 826 12 81 (secretary)  
fax: +48 22 826 98 15  
fax: +48 22 826 73 80



The Institute is one of the largest scientific establishments of the Polish Academy of Sciences.

The main activity of the Institute is to conduct high-quality research in the areas of interest of the world's science and technology. The most important fields of the Institute's expertise include advanced problems in modern mechanics, materials science, electronics and biomedical engineering, information and computational science. Extensive research is conducted especially in nanoscience and nanotechnology, micro- and nano-materials, multicomponent and multifunctional materials, biomaterials, computational mechanics, computational materials science, computational intelligence, computational biology and bionformatics, multiscale engineering, ultrasonic medical diagnostics and smart technologies.

Advanced research is also conducted in several branches of fundamental science and technology, such as physics and thermodynamics of continua, fluid and experimental mechanics, laser beam interaction with metal surfaces, nanophotonic and applied mathematics.

The Institute has an extensive experience in international co-operation, initiating and coordinating international projects and in organising international conferences.



*65 years*

INSTITUTE OF FUNDAMENTAL TECHNOLOGICAL RESEARCH  
POLISH ACADEMY OF SCIENCES

Pawinskiego 5B, 02-106 Warszawa, Poland  
phone: +48 22 826 12 81, fax: +48 22 826 98 15, +48 22 826 73 80  
[www.ippt.pan.pl](http://www.ippt.pan.pl)

<http://rcin.org.pl>