

**Modern Approaches in Fuzzy Sets,
Intuitionistic Fuzzy Sets,
Generalized Nets and Related Topics
Volume II: Applications**

Editors

**Krassimir T. Atanassov
Władysław Homenda
Olgierd Hryniewicz
Janusz Kacprzyk
Maciej Krawczak
Zbigniew Nahorski
Eulalia Szmidt
Sławomir Zadrozny**

SRI PAS



IBS PAN



**Systems Research Institute
Polish Academy of Sciences**

**Modern Approaches in Fuzzy Sets,
Intuitionistic Fuzzy Sets,
Generalized Nets and Related Topics.
Volume II: Applications**

Editors

**Krassimir Atanassov
Władysław Homenda
Olgierd Hryniewicz
Janusz Kacprzyk
Maciej Krawczak
Zbigniew Nahorski
Eulalia Szmidt
Sławomir Zadrozny**



© **Copyright by Systems Research Institute
Polish Academy of Sciences
Warsaw 2014**

All rights reserved. No part of this publication may be reproduced, stored in retrieval system or transmitted in any form, or by any means, electronic, mechanical, photocopying, recording or otherwise, without permission in writing from publisher.

Systems Research Institute
Polish Academy of Sciences
Newelska 6, 01-447 Warsaw, Poland
www.ibspan.waw.pl

ISBN 83-894-7554-5

Generalized net model of decision support system of wildland fire estimation. the case of Harmanli fire (Bulgaria) 2009

Nina Dobrinkova

Institute of Information and Communication Technologies
Bulgarian Academy of Sciences,
Acad. G. Bonchev Str., Block 2, 1113 Sofia, Bulgaria
e-mail nido@math.bas.bg

Georgi Jordanov

Institute for Geophysics, Geodesy and Geography
Bulgarian Academy of Sciences,
Acad. G. Bonchev Str., Block 3, 1113 Sofia, Bulgaria
e-mail gjordanov@geophys.bas.bg

Peter Vassilev

Institute of Biophysics and Biomedical Engineering,
Bulgarian Academy of Sciences,
Acad. G. Bonchev Str., Block 105, 1113 Sofia, Bulgaria
e-mail peter.vassilev@gmail.com

Abstract

During the last years in Bulgaria the number of forest fires has increased and the need of computer based tools also. A generalized net representation of a possible automated system for forest fire spread estimation is presented. The team in the Bulgarian Academy of Sciences has focused its efforts in creation of methodology for simulations in parallel mode the fire propagation by using the WRF-Fire model (recently renamed to SFIRE). We have run simulation with real data about forest fire near by the village of Leshnikovo, region of Harmanli, that occurred from 14 to 17 August 2009 by

Modern Approaches in Fuzzy Sets, Intuitionistic Fuzzy Sets, Generalized Nets and Related Topics. Volume II: Applications (K.T. Atanassov, W. Homenda, O. Hryniewicz, J. Kacprzyk, M. Krawczak, Z. Nahorski, E. Szmidt, S. Zadrozny, Eds.), IBS PAN - SRI PAS, Warsaw, 2014

using US supercomputer. Now our team will run the model and the created data for the real case in Harmanli region on the Bulgarian Blue Gene/P architecture and will compare the results from the parallel computations.

Keywords: Generalized Net, Fire Spread Modelling, Simulation

1 Introduction

In the recent years many statistics have been done in Europe about the forest fires that occur on the territory of the European Union. Bulgaria has not been included, but the Bulgarian authorities have been keeping their own statistics where it is shown that Bulgarian forest fires in the last 30 years have increased their number and in the year 2000 was noticed even a peak about this natural hazard. In 2003 [3] in the protected zone of national park Pirin on 23 of July in the late afternoon fire occurred in forest of special type black-needle trees, very expensive because of the wood. The fire burned 600 hectares, but 3 casualties from the military team participating in the flight of MI-17 helicopter died. The reason for the catastrophe was that the helicopter flew very near to the burning fire flames, where the oxygen content is very limited and that caused the engine to stop. Also the forest fires are bringing local meteorological conditions while burning, which was not known fact by the helicopter pilot and that cost all passengers lives. In 2007 according to Civil protection reports [4] extremely high temperatures have been measured during July and that brought one more time a discussion about development of a national wildfire alert system, which could be further developed into wildfire decision support system. For this reason our team has focused on exploration of the WRF-Fire (SFIRE) model capabilities and its applicability in the every day operational work of the fire-fighter brigades in Bulgaria.

Further we will present a Generalized net model (see [1]) of an automated system to represent forest fire spread and then we will discuss some results that were achieved on the US cluster Janus as well as the first runs with the same data on the Bulgarian supercomputer Blue Gene/P using WRF-Fire (SFIRE).

We will briefly note that there have been alternative attempts at modelling wildfire development, particularly by the game method for modelling (similar to cellular automata) paradigm (see [2]), e.g. [18, 19].

2 Generalized net model

Here we present a GN model of an automated system to predict forest fire spread in order to design a software tool capable of importing/processing and interpreting

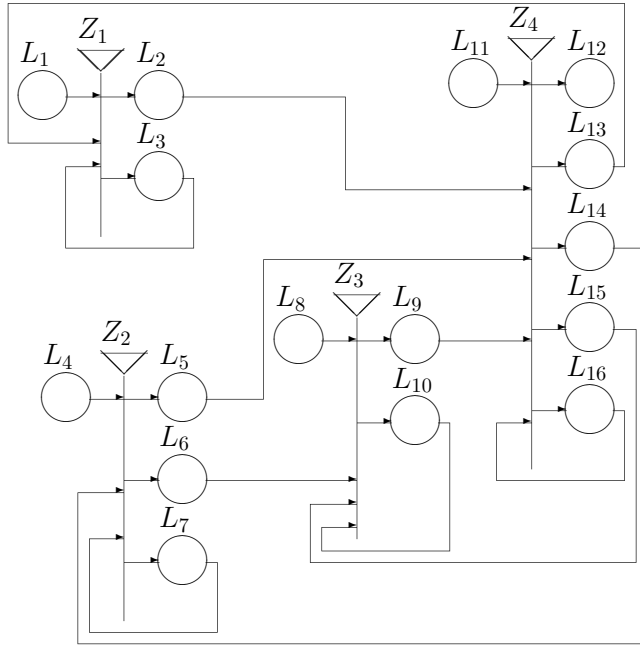

Figure 1: Generalized Net Model of a System Predicting Fire Development

data from available sources to be used in a model.

The generalized net consists of four transitions and sixteen places. Five types of token are running in the net $\alpha, \beta, \gamma, \delta$ - and ε -tokens. The α -tokens represent weather conditions (in particular wind velocity, humidity, etc.) accessible by either measurement or data retrieval from database(s), websites, etc. The β -tokens correspond to accessible data regarding the specific landscape topography of the region. The γ tokens correspond to the available burning material(s) distribution in the area, retrieved from accessible data. The δ -tokens contain information regarding the fire – such as point(s) of origin, etc. The ε -token corresponds to the model used to predict the way the fire develops.

Further we give the formal definitions of each transitions and add descriptions, wherever necessary. In place L_1 enter α -tokens with additional characteristic: “total number of available data repositories; time of access; repository number; format”

$$Z_1 = \langle \{L_1, L_3, L_{13}\}, \{L_2, L_3\}, \begin{array}{c|cc} & L_2 & L_3 \\ \hline L_1 & false & true \\ L_3 & W_{3,2} & W_{3,3} \\ L_{13} & false & true \end{array} \rangle,$$

where

$W_{3,2}$ = “All available repositories have been checked & “time of access”= current time & format is compatible & format contains the required data.”

$W_{3,3}$ = “format needs to be converted”

In other words, we require that the best possible information is passed to the simulation tool and it is only passed in interpretable format. Here, for simplicity, we are omitting the possibility to aggregate data from different repositories, which is also a viable option. In place L_3 all the checks and reformatting is done and the data is the input into the model.

In place L_4 enter β -tokens with additional characteristic:
“total number of available data repositories; time of access; repository number; format; resolution”

$$Z_2 = \langle \{L_4, L_7, L_{14}\}, \{L_5, L_6, L_7\}, \begin{array}{c|ccc} & L_5 & L_6 & L_7 \\ \hline L_4 & false & false & true \\ L_7 & W_{7,5} & W_{7,6} & W_{7,7} \\ L_{14} & false & false & true \end{array} \rangle,$$

where

$W_{7,5}$ = “All available repositories have been checked & “time of access”= current time & format is compatible & format contains the required data & resolution is optimal & no additional data is required by the model.”

$W_{7,6}$ = “All available repositories have been checked & “time of access”= current time & format is compatible & format contains the required data & resolution is optimal & burning material aggregation into the data is required.”

$W_{7,7}$ = “format needs to be converted to usable form”

In place L_7 all the checks and reformatting is done and the data is the input into the model. Here we assume two cases - area has almost homogeneous composition of burning material, in which case we only need to pass the topography data to the simulation tool (L_5), or as in most cases (L_6) the composition is heterogeneous, in which case we need to integrate the burning material data and then pass it to the simulation tool.

In place L_8 enter γ -tokens with additional characteristic:
“total number of available data repositories; time of access; repository number; format”

$$Z_3 = \langle \{L_6, L_8, L_{10}, L_{15}\}, \{L_9, L_{10}\}, \begin{array}{c|cc} & L_9 & L_{10} \\ \hline L_6 & false & true \\ L_8 & W_{8,9} & W_{8,10} \\ L_{10} & W_{10,9} & W_{10,10} \\ L_{15} & false & true \end{array} \rangle,$$

where

$W_{8,9}$ = “All available repositories have been checked & “time of access”= current time & format is compatible & format contains the required data & no additional data is required by the model.”

$W_{8,10}$ = “All available repositories have been checked & “time of access”= current time & format is compatible & data integration has to be done.”

$W_{10,9}$ = “All available repositories have been checked & “time of access”= current time & format is compatible & format contains the required data & burning material values have been integrated with topography data.”

$W_{10,10}$ = “format needs to be converted to usable form”

In place L_{10} all the checks, reformatting and data integration is done. From L_9 the data is input in the model (simulation tool).

In place L_{11} enter δ -tokens with additional characteristic: “time; fire information”

Another ε -token also enters from L_{11} with initial characteristics: “supported format; required data; computation rules”

$$Z_4 = \langle \{L_2, L_5, L_9, L_{11}, L_{16}\}, \{L_{12}, L_{13}, L_{14}, L_{15}, L_{16}\},$$

	L_{12}	L_{13}	L_{14}	L_{15}	L_{16}	
L_2	<i>false</i>	<i>false</i>	<i>false</i>	<i>false</i>	<i>true</i>),
L_5	<i>false</i>	<i>false</i>	<i>false</i>	<i>false</i>	<i>true</i>	
L_9	<i>false</i>	<i>false</i>	<i>false</i>	<i>false</i>	<i>true</i>	
L_{11}	<i>false</i>	<i>false</i>	<i>false</i>	<i>false</i>	<i>true</i>	
L_{16}	$W_{16,12}$	$W_{16,13}$	$W_{16,14}$	$W_{16,15}$	$W_{16,16}$	

where

$W_{16,12}$ = “The simulation is completed.”

$W_{16,13}$ = “New meteorological data is required”

$W_{16,14}$ = “New topographical data is required.”

$W_{16,15}$ = “Additional data for the burning material distribution is required”

$W_{16,16}$ = “New simulation step needs to be performed & all required data for computation is available and in appropriate format.”

This generalized net representation allows for multiple runnings of simpler models in order to find optimal discrete intervals, data segmentations and/or rule updates. Also it allows to run in parallel several simulations based on different models and compare performance, accuracy and weak points of the implemented methods.

Further we have chosen WRF-Fire (SFIRE) as a tool to illustrate the above paradigm.

3 General description of the mathematical basis of WRF-Fire (SFIRE)

In this section we focus on atmosphere-fire modeling in WRF-Fire. It is based on [5] and [6], where more details can be found.

Fire models range from simple spread formulas to sophisticated computational fluid dynamics and combustion simulations, see [7] and [5, p. 50]. However, a fire behavior model in a decision support system should be faster than real time in order to deliver a prediction, which dictates a compromise between the spatial resolution, the processes to be modeled, and fast execution.

Weather has major influence on wildfire behavior; in particular, the fire spread speed is largely determined by the wind. Conversely, the fire influences the weather through the heat and vapor fluxes. Fire heat output can easily reach the surface intensity of 1 MW/m^2 , and the fast rising hot air causes a significant air motion that affects the atmosphere also away from the fire. It is known that a large fire “creates its own weather.” The correct fire shape and progress result from the two-way interaction of the fire and the atmosphere [8, 9].

WRF-Fire [5] combines the Weather Research and Forecasting Model (WRF) [10] with a semi-empirical fire spread model from [8], based on modified Rothermel’s formula, which approximates the fire spread rate in the normal direction to the fireline as a function of fuel properties, wind speed close to the ground, and terrain slope. The semi-empirical model approximates the rate of the fuel decay by burning by an exponential in time. The semi-empirical formulas were derived from laboratory experiments, and the coupled model was verified on several large fires [9] in an earlier implementation, with the fire propagation by tracers and atmospheric modeling by the Clark-Hall weather code. WRF-Fire takes advantage of this validation and implements a subset of the physical model from [8, 9]. The fire spread in WRF-Fire is implemented by the level-set method [11]. The level-set function can be manipulated more easily than tracers. The weather model has been replaced by WRF, a supported standard community weather code. WRF can

be run with several nested refined meshes, called domains in meteorology, which can run different physical models. The fundamental observation here is that the innermost domain, which interacts directly with the fire model, needs to run in the Large Eddy Simulation (LES) mode [12]. WRF-Fire takes advantage of the mature WRF infrastructure for parallel computing and for data management. An important motivation for the development of the WRF-Fire software was the ability of WRF to export and import state, thus facilitating data assimilation (input of additional data while the model is running), which is essential for fire behavior prediction from all available data [13].

WRF contains the WRF Preprocessing System (WPS) [14, Chapter 3], which can input meteorology and land use data in a large number of commonly used formats. WPS has been extended to process fine-scale land data for use with the fire model, such as topography and fuel information in [15] and [14, Appendix A]. While the format of meteorology data has largely stabilized, the ingestion of fire-modeling data was developed for U.S. sources only, and it will require further modifications or preprocessing for other countries.

Mathematically, the fire model is posed in the horizontal (x, y) plane. The semi-empirical approach to fire propagation used here assumes that fire spreads in the direction normal to the fireline at the speed given by the modified Rothermel's formula

$$S = \min\{B_0, R_0 + \phi_W + \phi_S\},$$

where B_0 is the backing rate (spread rate against the wind), R_0 is the spread rate in the absence of wind, $\phi_W = a(\vec{v} \cdot \vec{n})^b$ is the wind correction, and $\phi_S = d\nabla z \cdot \vec{n}$ is the terrain correction. Here, \vec{v} is the wind vector, ∇z is the terrain gradient vector, and \vec{n} is the normal vector to the fireline in the direction away from the burning area. In addition, the spread rate is limited by $S \leq S_{\max}$. Once the fuel is ignited, the amount of the fuel at location (x, y) is given by

$$F(x, y, t) = F_0(x, y)e^{-(t-t_i(x,y))/T(x,y)}, \quad t > t-t_i(x, y) \quad (1)$$

where t is the time, t_i is the ignition time, F_0 is the initial amount of fuel, and T is the time constant of fuel (the time for the fuel to burn down to $1/e$ of the original quantity). The coefficients $B_0, R_0, a, b, d, S_{\max}, F_0,$ and T are data.

The heat flux from the fire is inserted into the atmospheric model as Runge-Kutta Time Integration Scheme where ordinary differential equations are set using a predictor-corrector formulation. Defining the prognostic variables in the atmospheric model the solver is defined as $\Phi = (U, V, W, \Theta, \phi', \mu', \Theta_m)$ and the model equations as $\Phi_t = R(\Phi)$ realized in 3 steps to advance the solution [12] and [6]. The sensible heat flux is inserted as the time derivative of the temperature, while

the latent heat flux as the derivative of water vapor concentration. This scheme is required because atmospheric model with explicit timestepping, such as WRF, do not support flux boundary conditions. The heat fluxes from the fire to the atmosphere are taken proportional to the fuel burning rate, $\partial F(x, y, t) / \partial t$. The proportionality constants are again fuel coefficients.

For each point in the plane, the fuel coefficients are given by one of the 13 Anderson categories [16]. The categories are developed for the U.S. and assume wind measured at a certain altitude. WRF-Fire provides for the definition of the categories as input data and the specification of the altitude of the wind input into the spread formula, which allows the software to adapt to other countries.

The burning region at time t is represented as the set of all points (x, y) where a level set function $\phi(x, y, t) < 0$. The level set function satisfied the partial differential equation,

$$\partial\phi/\partial t = -S|\nabla\phi|, \quad (2)$$

where $|\nabla\phi|$ is the Euclidean norm of the gradient [11].

In each time of the atmospheric model, first the winds are interpolated from the atmospheric model grid to a finer fire model grid. A numerical scheme for the level set equation (2) is then advanced to the next time step value, and the fuel burned during the time step is computed by quadrature from (1) in each fire model cell. The resulting heat fluxes are averaged over the fire cells that make up one atmosphere model cell.

4 Experimental results on the US cluster

This section has been based on [17], where all details can be found, but we will present here also brief summary of the achieved results. The experimental tasks which we did at first have been performed on the Janus cluster at the University of Colorado. The computer consists of nodes with dual Intel X5660 processors (total 12 cores per node), connected by QDR InfiniBand. The very first run on the model was with ideal case using coordinates and information for village Zheleznitsa. We used WRF-Fire v.3.2 for the simulation. We did a domain of size 4 by 4 km, with horizontal resolution of 50 m, for the atmosphere mesh, we used 80 by 80 grid cells and with 41 vertical levels from ground surface up to 100 hPa. Nesting was not used, keeping the ideal case as basic as possible, in order to evaluate the model capacity. The domain, which we set was located 4 km west from village Zheleznitsa in the south-east part of Sofia district. The domain was covering the lower part of the forest part of Vitosha mountain. The ignition line which we used was set in the center of the domain and to ignite it 345 m long line was set. The

model does not consider ignition from point, because the atmospheric model does not cover such measurements yet and this is still part of its future development. The ignition in parallel has been set to start 2 seconds after the simulation has begun. The results from this first simulation with real data gave us idea how the model can be initialized and what the input data will be if we start simulation with real case forest fire for calibration of the model. That is why we selected from the national data base in the ministry of forests, food and agriculture fire which has been burning in the period 14-17 August 2009. For the initialization of the model with real case we had to use algorithm for implementation of the real data in a way WRF-Fire (SFIRE) can recognize it. We set two domains; the first was covering area of 48 square km with resolution 300m (160x160). This domain was producing boundary and initial meteorological conditions for the inner domain and in this domain there were no fire simulations. The inner domain was located in the middle of the coarse domain. The resolution in Domain 2 was set as 60 m and the area covered was 9.6 square km (161x161). Domain 2 was centered on the fire ignition line and it was covering the areas of villages Ivanovo, Leshnikovo and Cherna Mogila. This area was located in South-East Bulgaria close to the Bulgarian-Greece border. The first data source which is very important is the meteorological input. We use US NCEP Global Analyses data for meteorological background input: The data is with 1x1 degree grid resolution covering the entire globe, the time resolution is 6 hours. With this data we can simulate all over the world but with resolution of around 100 km. The next data set needed for input in WPS (WRF pre-processor) is topography data. The standard topo-data used in WPS is USGS 30sec resolution global data set (GTOPO30), but because terrain elevation is very important for correct fire behavior. We used much more detailed data for the area of Harmanli (this data is available also for the whole country of Bulgaria) from USGS/SRTM 3sec data (<http://eros.usgs.gov> ; Shuttle Radar Topography Mission (SRTM) Finished Grade Data) which to be used in WPS had to be converted in a special format. The data received from the server is a GIS raster format (DTED format *.dt1) in Lat/Long format, datum WGS84. Using the powerful open-source Quantum GIS (www.qgis.org) we open the downloaded raster and first interpolate the missing data (if any) with simple linear interpolation and then we can change the projection to the one we are going to use in WRF Lambert Conformal Conic (*ref_lat = 41.84, ref_lon = 25.936, truelat1 = 41.82, truelat2 = 41.86, stand_lon = 25.936*). After the reprojecting, we export the raster in the new format – GeoTiff. This format than is going to be used in the WPS program *convert_geotiff*. As final result on the simulations done for the real data of the area of village Leshnikovo we got image very similar to the one which has been the actual burnt area. The images can be seen on Figure 2 - real burnt area

according to [17], and Figure 3 - simulated burnt area according to [17].



Figure 2: The real fire burnt area based on [17].

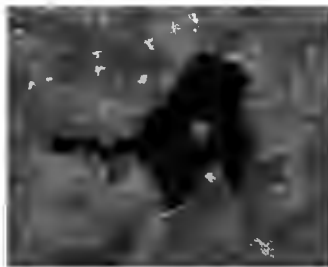

Figure 3: The simulation burnt area based on [17].

From the two pictures it is obvious that there are some differences, but the final shape from the simulated result and the real burned area are quite close. That difference is because the used data sources are not giving us very detailed information, but the initialization has been done and the model run also with Bulgarian data.

5 Experimental results on Blue Gene/P

The Bulgarian Supercomputing Center is located at the State Agency for Information Technology and Communications in Sofia, which operates and provides access to the supercomputer IBM Blue Gene/P. Its configuration consisted of two racks, 2048 with computational nodes connected by PowerPC lines, 450 processors, 8192 cores and total 4 TB operational memory. Every core can process two data streams (with double precision) after the floating point. Sixteen input-output nodes are connected by optical connection 10 Gb/s Ethernet, and another extra sixteen input-output nodes will be added to the system in the near future. The smallest share of the machine that can be devoted to solving a task now consists of 128 computational nodes (512 processor cores). We performed for first time runs of the WRF-Fire (SFIRE) model on the Blue Gene/P architecture. This is our next step after performing the runs of the US cluster Janus. The input data used for the simulation is for the same test area near by the village of Leshnikovo as the study done on the US Janus cluster. Nesting is used and domain 1 is 180x180 points with 250 m resolution, the time step is 0.5 sec and 41 vertical levels. Domain one is only used to get better boundary and initial conditions for the finer domain 2, and no fire is set up in domain 1. Domain 2 is 221x221 points with 50 m resolution, time step is 0.1 sec, 41 vertical levels and fire mesh resolution is

5m. The simulation starts at 06:00 UTC and it is 2.5 min long, and the time for the simulation to be completed using only 100 processors is 7 h 43 min, which gives the real-time coefficient - 0.0054, much below 1. The reason for this slow calculation is the very small time step of 0.1 sec. Further model runs will be made to determine the optimum time step and also future runs will use the full capacity of the Blue Gene/P with more than 1000 processors.

6 Conclusion

A Generalized net model of an automated forest estimation system has been proposed. Based on it a WRF-Fire (SFIRE) implementation was done. It is shown that the WRF-Fire (SFIRE) model is applicable for Bulgarian conditions and it can be used for more accurate simulations. The only requirement for this is availability of real operational meteorological data on every 3 hours at least, in order to get better meteorological initialization of the atmosphere part of the model.

Acknowledgements

This work has been partially supported by the Bulgarian National Science Fund under the grant "Simulation of wild-land fire behavior" - I01/0006 and by the PRACE project funded in part by the EUs 7th Framework Programme (FP7/2007-2013) under grant agreement no. RI-211528 and FP7-261557.

References

- [1] Atanassov K. (1991) Generalized Nets, World Scientific, Singapore, New Jersey, London.
- [2] Atanassov K. (2012) On the game method for modelling. Advanced Studies in Contemporary Mathematics, (22)2, 189–207.
- [3] http://news.ibox.bg/news/id_1888536796 (accessed on 25 July 2013)
- [4] http://ec.europa.eu/echo/civil_protection/civil_forestfires_bg_2007.htm (last accessed on 25 July 2013)
- [5] Mandel J., Beezley, J.D. Coen, J.L. Kim, M. (2009) Data assimilation for wildland fires: Ensemble Kalman filters in coupled atmosphere-surface models. IEEE Control Systems Magazine, 29, 47-65

- [6] Coupled atmosphere-wildland fire modeling with WRF 3.3 and SFIRE 2011, *Geoscientific Model Development (GMD)* 4, 591-610, 2011. doi:10.5194/gmd-4-591-2011
- [7] Sullivan A.L.: A review of wildland fire spread modelling, 1990-present (2009). 1: Physical and quasi-physical models, 2: Empirical and quasi-empirical models, 3: Mathematical analogues and simulation models. *International Journal of WildLand Fire*, 18, 1: 347-368, 2: 369-386, 3: 387-403
- [8] Clark T.L., Coen, J., Latham D. (2004) Description of a coupled atmosphere-fire model. *International Journal of Wildland Fire*, 13, 49-64
- [9] Coen J.L. (2005) Simulation of the Big Elk Fire using coupled atmosphere-fire modeling. *International Journal of Wildland Fire*, 14(1), 49-59
- [10] WRF Working Group: Weather Research Forecasting (WRF) Model. <http://wrf-model.org> (last accessed 25 July 2013)
- [11] Osher S., R. Fedkiw (2003) Level set methods and dynamic implicit surfaces. Springer-Verlag, New York
- [12] Patton E.G., Coen J.L. (2004) WRF-Fire: A coupled atmosphere-fire module for WRF. In: Preprints of Joint MM5/Weather Research and Forecasting Model Users Workshop, Boulder, CO, June 2225. NCAR 221-223 http://www.mmm.ucar.edu/mm5/workshop/ws04/Session9/Patton_Edward.pdf.
- [13] Mandel J., Chen, M. Franca, L.P. Johns, C., Puhalskii A., Coen, J.L. Douglas, C.C. Kremens R., Vodacek A., Zhao W.: A note on dynamic data driven wildfire modeling. In Bubak M., van Albada, G.D. Sloot, P.M.A. Dongarra J.J., eds.(2004) Computational Science - ICCS 2004. Volume 3038 of Lecture Notes in Computer Science. Springer 725-731
- [14] Wang, W. Bruyere, C. Duda, M. Dudhia, J., Gill D., Lin H.C., Michalakes J., Rizvi S., Zhang X., Beezley J.D., Coen J.L., Mandel J. (2010) ARW version 3 modeling system users guide. Mesoscale and Microscale Meteorology Division, National Center for Atmospheric Research http://www.mmm.ucar.edu/wrf/users/docs/user_guide_V3/ARWUsersGuideV3.pdf.
- [15] Beezley, J.D.: How to run WRF-Fire with real data. http://www.openwfm.org/wiki/How_to_run_WRF-Fire_with_real_data (last accessed July 25 2013)

- [16] Anderson H.E. (1982) Aids to determining fuel models for estimating fire behavior. USDA Forest Service, Intermountain Forest and Range Experiment Station, Research Report INT-122 <http://digitalcommons.usu.edu/cgi/viewcontent.cgi?article=1147&context=barkbeetles>
- [17] Jordanov G., Beezley J.D., Dobrinkova N., Kochanski A.K., Mandel J. (2012) “Simulation by WRF-Fire of the 2009 Harmanli Fire (Bulgaria)”. Lecture Notes in Computer Science, 7116, Science, Springer Germany, 291–298.
- [18] Sotirova E., D. Dimitrov, K. Atanassov. (2012) On some applications of game method for modeling. Part 1: Forest dynamics, Proceedings of the Jangjeon Mathematical Society, 15 (2), 115–123.
- [19] Sotirova E., N. Dobrinkova, K. Atanassov. (2012) On some applications of game method for modeling. Part 2: Development of forest fire, Proceedings of the Jangjeon Mathematical Society, 15, (3), 335–342.

The papers presented in this Volume 2 constitute a collection of contributions, both of a foundational and applied type, by both well-known experts and young researchers in various fields of broadly perceived intelligent systems.

It may be viewed as a result of fruitful discussions held during the Twelfth International Workshop on Intuitionistic Fuzzy Sets and Generalized Nets (IWIFSGN-2013) organized in Warsaw on October 11, 2013 by the Systems Research Institute, Polish Academy of Sciences, in Warsaw, Poland, Institute of Biophysics and Biomedical Engineering, Bulgarian Academy of Sciences in Sofia, Bulgaria, and WIT - Warsaw School of Information Technology in Warsaw, Poland, and co-organized by: the Matej Bel University, Banska Bystrica, Slovakia, Universidad Publica de Navarra, Pamplona, Spain, Universidade de Tras-Os-Montes e Alto Douro, Vila Real, Portugal, Prof. Asen Zlatarov University, Burgas, Bulgaria, and the University of Westminster, Harrow, UK:

[Http://www.ibspan.waw.pl/ifs2013](http://www.ibspan.waw.pl/ifs2013)

The consecutive International Workshops on Intuitionistic Fuzzy Sets and Generalized Nets (IWIFSGNs) have been meant to provide a forum for the presentation of new results and for scientific discussion on new developments in foundations and applications of intuitionistic fuzzy sets and generalized nets pioneered by Professor Krassimir T. Atanassov. Other topics related to broadly perceived representation and processing of uncertain and imprecise information and intelligent systems have also been included. The Twelfth International Workshop on Intuitionistic Fuzzy Sets and Generalized Nets (IWIFSGN-2013) is a continuation of this undertaking, and provides many new ideas and results in the areas concerned.

We hope that a collection of main contributions presented at the Workshop, completed with many papers by leading experts who have not been able to participate, will provide a source of much needed information on recent trends in the topics considered.

ISBN 838947554-5



9 788389 475541