

Experimental study on visual information transmission at driving automobile for reliability-based design

K. YAMANAKA¹⁾, H. NAKAYASU²⁾ and K. MAEDA³⁾

¹⁾ *Graduate School of Information and Systems Science, Konan University
8-9-1 Okamoto, Higashinada-ku, Kobe 658-8501, Japan
kimihiro@hcc1.bai.ne.jp*

²⁾ *Department of Information Science and Systems Engineering
Faculty of Science and Engineering
HRC (High Technology Research Center), Konan University
8-9-1 Okamoto, Higashinada-ku, Kobe 658-8501, Japan
nakayasu@konan-u.ac.jp*

³⁾ *Department of Information Science and Systems Engineering
Faculty of Science and Engineering, Konan University
8-9-1 Okamoto, Higashinada-ku, Kobe 658-8501, Japan
kmaeda@konan-u.ac.jp*

It is examined by the experiment what kinds of factors are sensitive to the useful field of view at driving situation of automobile. There are two kinds of experiments carried out. One is to measure the region of the useful field of view that is the region to detect a simple white circle. The other is to measure the region of the useful field of view that is the region to be able to recognize a specific shape in Snallen's chart. The region measured in the former experiment called as "detectable field of view", and that in the latter experiment is called as "recognized field of view". Response time is also measured with the electrical potentials in the experiment. The typical useful experimental results were represented in the paper. A new model for visual information processing was proposed in order to consider the process and mechanism of constructing the useful field of view. The event related potential P300 was measured to verify the relationship between the experimental results and proposed process model.

Key words: *Three-dimensional Vision, Useful field of view, Event related potentials (ERP), P300.*

1. Introduction

There are various kinds of definitions for the field of view, because of the distinctions of the professional field. The width of stationary field of view can be illustrated as Fig.1 [1]. The region in Fig.1 shows the width for various field of view which are measured with a constraint of fixation of eye. As shown in this figure, the biggest region is called the static/kinetic field in psychology that is also called the stationary field in medical science. This field means the region where one can find the unique circle mark under uniform background scene. From Fig.1, when the visual task increases, the region becomes narrower. The distinction between visibility and conspicuity field is in the condition of background. The former field is measured under uniform background; the latter field is under complicated background. The distinction between conspicuity and working conspicuity field is in additional visual task. From these definitions it is seen that the field of view measured in this experiment is equivalent to the working conspicuity field in psychological terminologies [1].

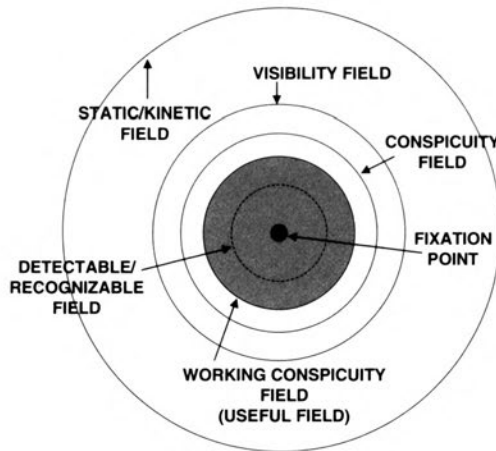

FIGURE 1. Width of field of view [1].

It is a problem that there are no standards of the way of measurement of the field within the visibility field. However, the useful field is the most important region which is of interest, since the characteristics of this region strongly depend upon the kind of visual task with high order function of brain such as the work of driving automobile, train, aircraft and operation of control equipment of nuclear power plant and so on. Therefore, there are various kind of terminology for useful field, that are also called as the useful

field of view, functional visual field, range of cue utilization, conspicuity area and attention field [2].

From the reasons mentioned the above, in this paper the new definitions of useful field are utilized in order to distinguish the meaning of useful field, as shown in Table 1, such as the detectable and recognizable field, though both the fields are equivalent to a working conspicuity field in psychophysics [1]. In this paper the human function is studied by the experiments when one recognizes the visual stimulus. In order to measure the useful field of view experimentally and to clarify the mechanism of the phenomena of visual tunnelling at driving situation, a new experimental paradigm was developed previously by the authors [3]. Our experimental system enables to evaluate the relation between the cognitive model on visual attention [4] and physiological signal when the driver recognizes a target mark as a visual stimulus in the laboratory.

TABLE 1. Classification of stationary field.

	PROPOSAL		CONVENTIONAL CLASSIFICATION (MEDICAL AND PSYCHOLOGICAL SCIENCE)		
180-200° degree	PERIPHERAL FIELD			PERIPHERAL VIEW	FIELD OF VIEW (MEDICAL AND PSYCHOLOGICAL SCIENCE)
4-20° degree	USEFUL FIELD	DETECTABLE FIELD	[VISUAL SENSOR, VISUAL RECOGNITION] USEFUL FIELD (BEDERMAN ET AL)/ DETECTABLE AND RECOGNIZABLE FIELD (MIURA)/ RESPONSE PERIPHERAL FIELD (MIURA)	(MEDICAL AND PSYCHOLOGICAL SCIENCE)	
		RECOGNIZABLE FIELD			
	FIXATION ON CENTER		[MEDICAL SCIENCE] FOVEAL VISION(UNDER1) PARAFOVEA(2-3deg) (KAKISAKI,1957)/ FOVEAL VISION(5.2deg) PARAFOVEA(8.6deg) (IKEDA,1975)	FOVEAL VISION (MEDICAL AND PSYCHOLOGICAL SCIENCE)	

2. Experiments for detectable and recognizable fields of view

The details of the experimental method and devices are discussed in [3]. Two kinds of experiments were carried out, whose schematic aspect is shown in Fig.2 and the conditions of experimental factors are listed in Tables 2 and 3. One is to measure the region of the useful field that is the region to detect a simple white circle as a target mark S_2 in the foreground scene as illustrated in Table 2. The region measured by this experiment is called “the

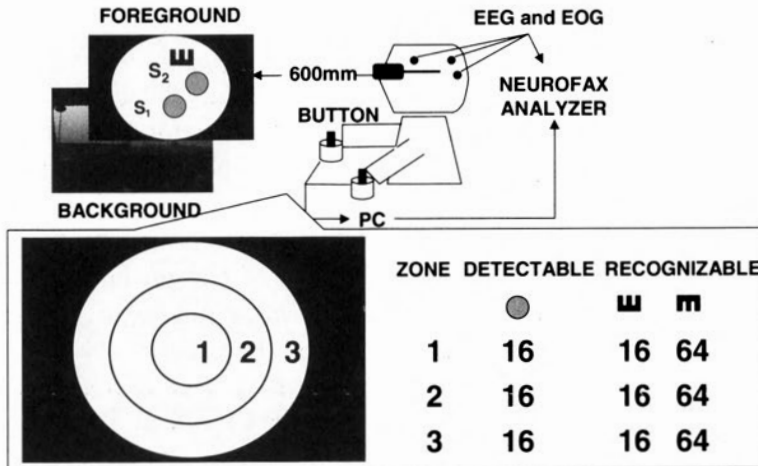

FIGURE 2. Appearance zone of target marks.

TABLE 2. Two kinds of experiment and visual stimulus signal in foreground scene.

	DETECTABLE		RECOGNIZABLE	
	SHAPE OF SIGNAL	DIS APPEARANCE RATE	SHAPE OF SIGNAL	DIS APPEARANCE RATE
S ₁	○ 0.48°	15cycles/min 53cycles/min	○ 0.48°	15cycles/min
S ₂	○ 0.48°	—	W TARGET M STANDARD	—

TABLE 3. Conditions of factors.

	1	2	SCENE
Ti : DISAPPEARANCE RATE OF S1	T ₁ : 15 cycles/min	T ₂ : 53 cycles/min	FOREGROUND SCENE
Vi : VELOCITY OF AUTOMOBILE	V ₁ : 40 km/h	V ₂ : 80 km/h	BACKGROUND SCENE
Di : TRAFFIC DEMAND	D ₁ : NON-CROWDED	D ₂ : CROWDED	

detectable field of view". Therefore this is "the experiment of a detectable". The other experiment is to measure the region of the useful field that is the region to be able to recognize a specific shape in Snallen's chart as a target mark among the standard marks with similar shape in Fig. 2 and Table 2. The region measured by the latter experiment is called "the recognizable field of view", and this experiment is called "the experiment of recognizable".

The two kinds of buttons were given to the subject in the left and right side hands as shown in Fig. 2. The subject must push the button of the right side as soon as possible, when one can detect or recognize the target mark S_2 in the foreground scene. On the other hand, the subject must put the mark of S_1 on by the left side button when S_1 disappears in order to fix the visual attention into the center of the scene. This is an additional task to recover the disappearance of S_1 for the purpose of fixation of visual attention. The factor T in Table 3 designates the factor of frequency of this additional task, where T_1 and T_2 mean the frequency of disappearance of S_1 such as 15 and 53 cycles per minutes, respectively. In the practical experiment, T_1 and T_2 are applied to the experiment of a detectable and only T_1 is applied to the experiment of recognizable. Thus, two kinds of visual task of detecting or recognizing the appearance of S_2 and the disappearance of S_1 are done. The details of these time charts of the appearance or disappearance of the signal S_1 and S_2 are shown in Fig. 3, where the duration time from the appearance of S_1 to that of S_2 is 1700 ms and the duration time of lighting of S_1 and S_2 is 500 ms. The signal of the left side click is saved in the PC. The response time from the appearance of S_2 to the reaction by examinee is also saved in PC.

The brightness is 18.1 lux in front of the CRT. The 3D movies are used for the background scene of the additional perceptive stimulus whose factors

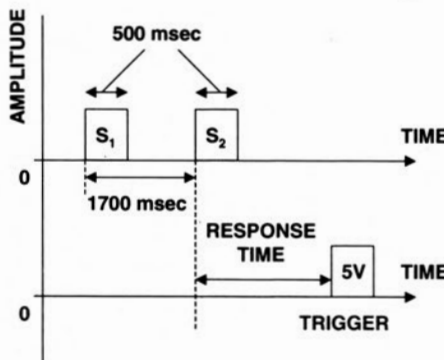

FIGURE 3. Time chart of S_1 - S_2 .

TABLE 4. Effectiveness of factors.

DETECTABLE	T	V	D	V multiple D	T multiple D	T multiple V
ANOVA	E*	N*	E	N	N	E
MEASUREMENT OF VISUAL FIELD	N	E	E*	—	—	—
RESPONSE TIME	E	N	N	—	—	—

RWCOGNIZABLE	—	V	D	V multiple D
ANOVA	—	N	E*	N
MEASUREMENT OF VISUAL FIELD	—	N	E*	—
RESPONSE TIME	—	E	E	—

E*: MORE EFFECTIVE

E: EFFECTIVE

N: LESS-EFFECTIVE

N*: NON-EFFECTIVE

of traffic condition V and D are also listed in Table 4. Several kinds of physiological signals are also measured by NeuroFax EEG-1518 (Nihon Kohden Inc.) or NeuroPack MEB-9100 (Nihon Kohden Inc.) such as EEG and ENG (electronystagmograph). In this experiment, the university students from 20 to 24 years old selected as candidates of subjects who have regular class automobile licenses with normal vision or corrected normal vision.

3. Experimental results

Table 4 shows the summary of the experimental results on effectiveness of factors that is evaluated from the experiment of detectable and recognizable. The second row in Table 4 means the results of the table of variance by ANOVA, where the response time is selected as an objective variable. The notation such as E^* means 5% significant factor by statistical judgment. It is seen that T is more effective factor and D and $T \times V$ are the effective factors in the experiment of a detectable. On the other hand, in the experiment of recognizable, it is also seen by ANOVA that D and $D \times V$ are more effective factors. The third and fourth rows in Table 4 are also the effectiveness of the factors by the subjective evaluations on response time and visual field. It is suggested that the factor D is the most sensitive factor from the total consideration in Table 4. It is noted that these results agree with those due to Miura [2, 4] performed with actual driving situation from the standpoint of psychological experiments.

TABLE 5. Response time and visual field.

RESPONSE TIME (msec)				
	D ₁ : NON-CROWDED	D ₂ : CROWDED		
V ₁ : 40 km/h	575	564	DETECTABLE	RECOGNIZABLE - DETECTABLE From 230 to 290 (msec)
	805	858	RECOGNIZABLE	
V ₂ : 80 km/h	558	597	DETECTABLE	
	824	850	RECOGNIZABLE	

VISUAL FIELD (degree)				
	D ₁ : NON-CROWDED	D ₂ : CROWDED		
V ₁ : 40 km/h	6.439	7.718	DETECTABLE	DETECTABLE - RECOGNIZABLE From 1.50 to 3.15 (degree)
	4.941	4.569	RECOGNIZABLE	
V ₂ : 80 km/h	6.664	6.715	DETECTABLE	
	4.782	5.110	RECOGNIZABLE	

The results of qualitative analysis of response time and width of the region of the field of view are listed in Table 5 for the conditions of *V* and *D*. From this table we conclude that the response time in experiment of detectable was shorter than that in the recognizable for every combination of conditions of *V* and *D*. On the other hand, it was also found that the region of visual field in the recognizable was narrower than that in the detectable. From Table 5 interesting results follow. First, the response time resulting from the experiment of detectable and recognizable ranges from 230 to 290 ms. Second, the width of visual field in a similar experiment ranges from 1.50° to 3.15°.

Another results of the behaviour on response time are represented in Fig. 4 for the appearance region of the target mark *S*₂. From this figure follows that in the experiment of detectable there are no differences among the appearance region of the target mark *S*₂ (zones 1, 2 and 3). On the other hand, in the experiment of the recognizable, there is a typical tendency that the wider the appearance region of target mark *S*₂, the longer the response time.

For the purpose of discussing the effect on the region of the target mark *S*₂ in the foreground scene and the traffic demand in the background scene, the relation between the response time and the factors on appearance region of target mark *S*₂ and traffic demand is investigated from the viewpoint of psychophysical aspect, whose results are shown in Figs. 5 and 6. At the same time, the relation between the amplitude of the related event potential P300 and the factors on appearance region of target mark *S*₂ and traffic demand are also investigated from the viewpoint of physiological aspect as well as

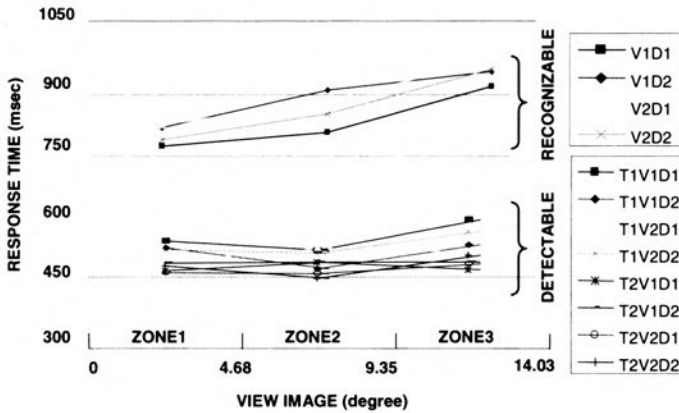

FIGURE 4. Response time for appearance region.

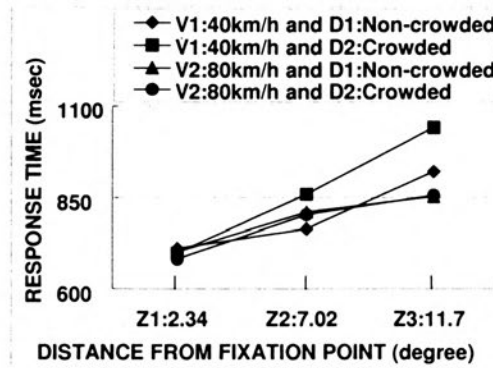

FIGURE 5. Response time for appearance region of target.

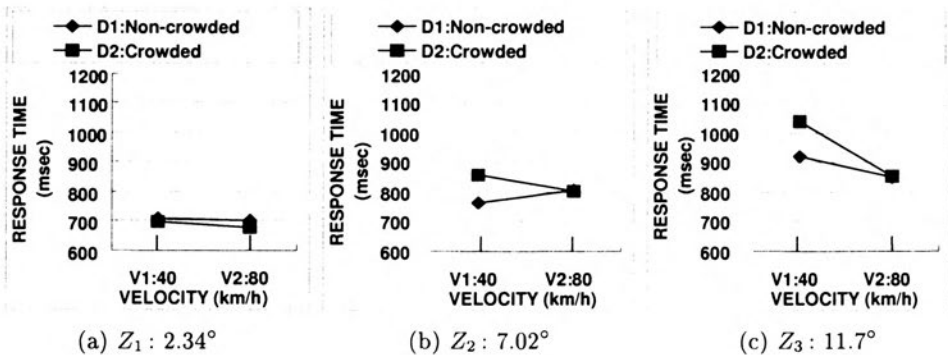

FIGURE 6. Response time for difference in speed and traffic demand.

the above, whose results are shown in Figs. 7 and 8. These investigations are performed only for the experiment of recognizable. In comparison with Figs. 5 and 7, it is interesting to note that the degree of related potential of P300 depends on the condition of traffic demand though that of response time is dependent on the appearance region. On the other hand, from the comparison of Figs. 6 and 8, we conclude that there are no correlations between V and D on the degree of related potential of P300, though it is seen at the behaviour of response time though there are strong correlations between V and D .

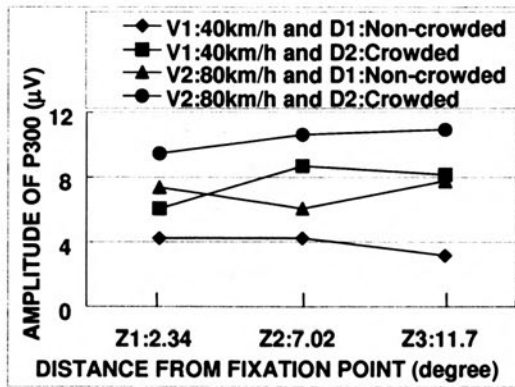

FIGURE 7. Amplitude of P300 for appearance region of target.

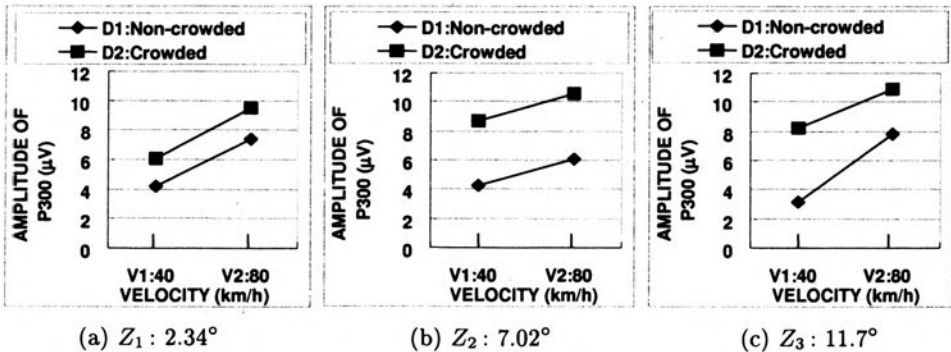

FIGURE 8. Amplitude of P300 for difference in speed and traffic demand.

4. Discussion

It is called as visual tunnelling, perceptual narrowing or tunnel vision that the region within the visibility field is narrower, when the additional visual task increases. In order to explain this mechanism, a new hypothesis of visual attention in the field of psychology has been proposed from the viewpoints of cognitive and psychophysical science [2, 4]. In this hypothesis, the reason of occurrence of visual tunnelling is due to two kinds of rules:

- R1: When the visual demand is more than the ordinary visual task, the distance from visual attention is out of the region of useful field.
- R2: When the visual demand is more than the ordinary visual task, there is less amount of overlapping of functional field.

In addition, in the hypothesis a new concept called cognitive momentum was also proposed by Miura [2], as a tool for the representation of the active characteristics for information processing. From this concept, the reason why the visual tunnelling occurs when the visual demand is more than the ordinary visual task is not due to the degradation of information processing, but due to adaptation to the change of situation for information processing. In other words, cognitive momentum means adaptation and optimization under the change of situation of information processing because of partition of resources in information processing.

On the other hand, a visual information process model is proposed in Fig. 9, where two kinds of channels correspond to recognize foreground and

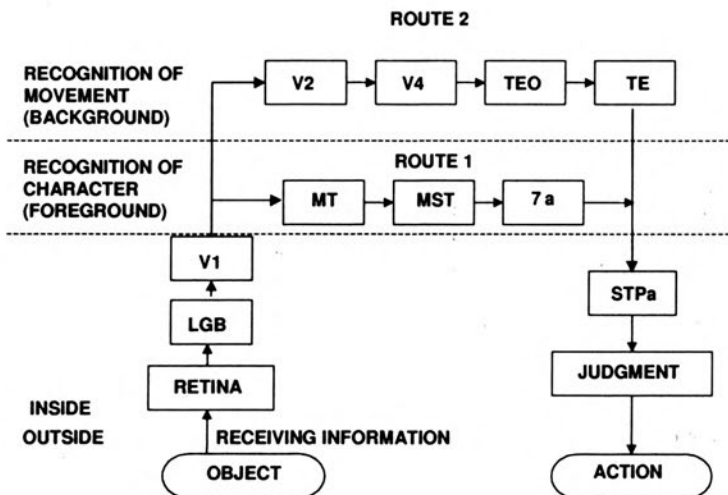

FIGURE 9. Visual information process model.

background scenes respectively, which is derived from the hypothesis of the route of visual information processing [2, 4]. As shown in the figure, the process for both experiments such as the detectable and recognizable are parallel processing in the path. In order to verify the validity of the proposed model, the event related potentials (ERP) were measured in the experiments, since it is well known that ERP are the potentials related to the specified cognition process. For the verification of the existence of channels in the proposed model, P300 is studied. Figure 10 shows an average of obtained potentials P300 on C_z . Since the character of P300 designates how much concentration happens under the psychological uncertainties, this signal enables to measure the degree of depth of information processing when one must judge whether the mark appears during recognizable experiment or not. Therefore, it is suggested that the degrees of visual attention such as depth of processing in the hypothesis by Miura [2, 4] in the previous section can be verified by these potentials. From this point of view, the potentials for the visual tasks were represented as an ensemble average of this related potential of P300 for each zone in Fig. 10. From Fig. 10 we conclude that the visual attention, that is a representation of depth of processing, was indicated as the ensemble average of the voltages for each zone, which coincides with the results of response time in Table 6. Particularly from Fig. 11 we infer that this tendency can be confirmed for each condition of V and D .

The behaviour of P300 in Fig.11 shows two kinds of typical features. The first is concerned with the effect of factors V and D in the background scene. The second is concerned with the effect of appearance zone of target marks.

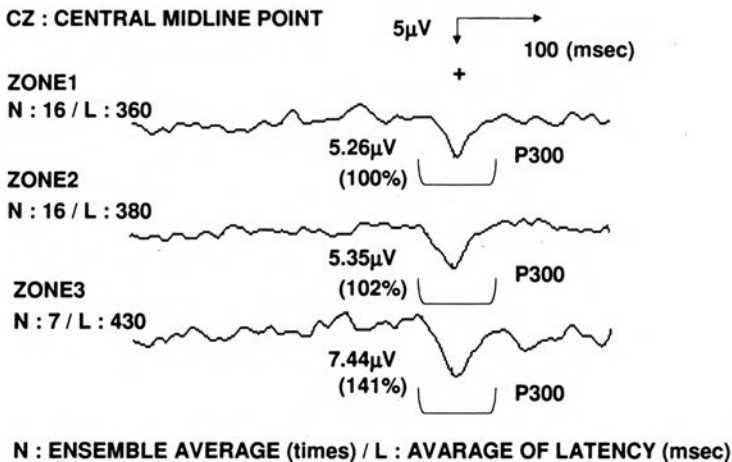

FIGURE 10. Event related potentials P300 on Cz.

TABLE 6. Comparison of response time for each zone.

RESPONSE TIME (msec)

	ZONE1	ZONE2	ZONE3
DETECTABLE	418	414	425
	100%	99%	102%
RECOGNIZABLE	692	734	802
	100%	106%	116%

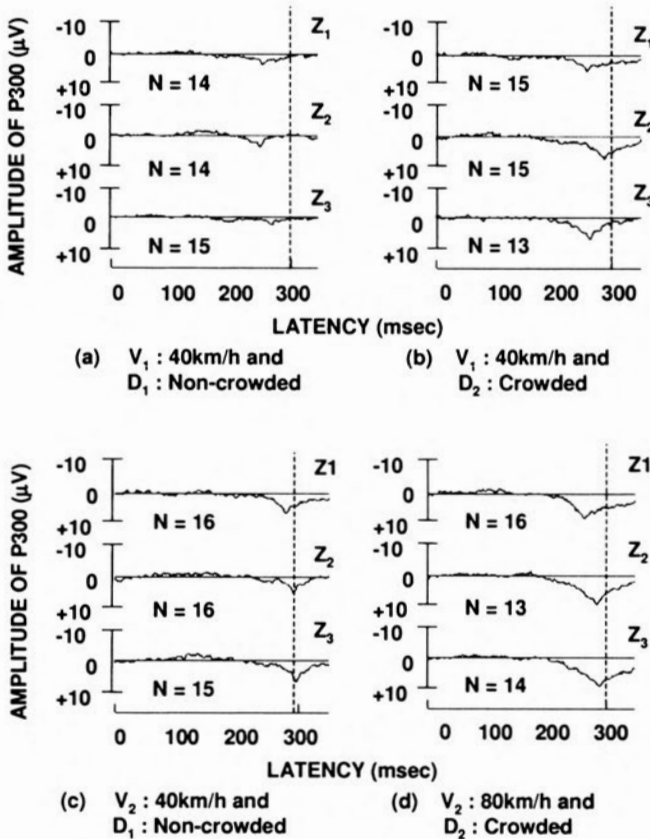

FIGURE 11. Event related potentials P300 on Cz.

In the former feature, it is found that there are big differences of the amplitude of P300 in comparison of (a) with (b) or of (c) with (d). This fact means that the effect of traffic demand D is strongly dependent on the depth of visual processing. On the other hand, it is found that there are little differences of the amplitude of P300 in comparison of (a) with (c) or of (b)

with (d). This shows that the factor V depends in a small degree on the depth of visual processing.

As the latter features, it is also seen that the longer the distance of appearance zone of target marks, the more difficult the task to recognize the target marks. This fact is suggested since the amplitude of P300 in zone 3 is bigger than that in zone 1 for any combination of the factors V and D .

In the proposed model in Fig. 9, there are two kinds of flow of visual information processing. The first is for recognizing the shape of the target marks in foreground scene. The second is the flow of recognizing traffic situation in background scene. From these points of view, the second flow needs more resource of visual processing when the traffic demand in background scene needs the deep visual processing. Therefore one must keep one's visual attention in mind since the first flow of visual processing for the task of judging whether the shape of the mark is target or not.

That is the reason why the amplitude of P300 in D_2 is larger than that in D_1 as well as the same reason, when the distance of appearance zone of the marks in foreground is for from fixation point, the amplitude of P300 becomes to be large. This tendency can also be explained by the same visual processing mechanism.

5. Conclusion

In this paper some primitive experiments such as the region of useful field of view were studied for the experiments of detectable and recognizable. The typical experimental results were as follows:

1. By the ANOVA of orthogonal table for experimental design, the factor of the duration time T of additional task was the most sensitive factor to response time in the experiment of a detectable. Both the experiment of detectable and recognizable, the factor of the velocity of vehicle V is not so sensitive but the factor of the traffic demand D is more sensitive to the response time. These results with Miura [2, 4] performed with actual driving situation from those due to the standpoint of psychological experiments.
2. The region of the useful field of view at the experiment of recognizable was narrower than that of a detectable. Similarly, the response time at the experiment of recognizable was longer than that of detectable.
3. By the measurement of EEG, it is seen that the amplitude of the event related potentials P300 on Cz were strongly dependent on the zone of the appearance of target marks in the experiment of recognizable.

4. It is suggested that the degrees of visual attention such as the depth of visual processing in the hypothesis by Miura of psychological field can be measured by an ensemble average of the related potential P300 at Cz.
5. A new model for visual information processing was proposed in order to consider the process and mechanism of constructing the useful field of view. The event related potential P300 was measured to verify the relationship between the experimental results and proposed process model. It was successfully verified that the proposed model enable to explain the experimental results that the velocity of an automobile in background scene is the most sensitive factor to the task of recognizing whether the marks is the target mark or not.

Acknowledgements

The authors express great thanks to the Grand-in Aid for Scientific Research Found of the Ministry of Education, Science Sports and Culture of Japan (Grant No.11650109) for their financial support and the Hirao Taro Foundation of the Konan University Association for Academic Research for their financial support.

References

1. T. OHYAMA, S. IMAI, T. WAKE, *Handbook of Sensory and Perceptive Psychology* (in Japanese), Seishinn Publisher Inc., pp.918-945, 1994.
2. T. MIURA, *Behaviour and Visual Attention* (in Japanese), Kazama Publisher Inc., 1996.
3. H. NAKAYASU, K. YAMANAKA and K. MAEDA, Development of experimental system of human function for reliability-based design, *Proc. Workshop on Reliability-Based design and Optimisation: RBO'02*, Warsaw 2002 (in press).
4. T. MIURA, K. SHINOHARA and K. KANDA, Visual attention in automobile driving: from eye movement study to depth attention study, *Proc. 2nd Int. Conf. on Psychophysiology in Ergonomics*, pp.7-8, 1998.
5. S. AMARI, K. TOYAMA, *Dictionary of Brain Science* (in Japanese), Asakura Publisher Inc., pp.120-125, 2000.



56174